

Antenna Electronics Concept for the Next-Generation Very Large Array

James Jackson, Robert Selina, William Shillue
National Radio Astronomy Observatory, Socorro, NM

Receivers & Integrated Digitizers

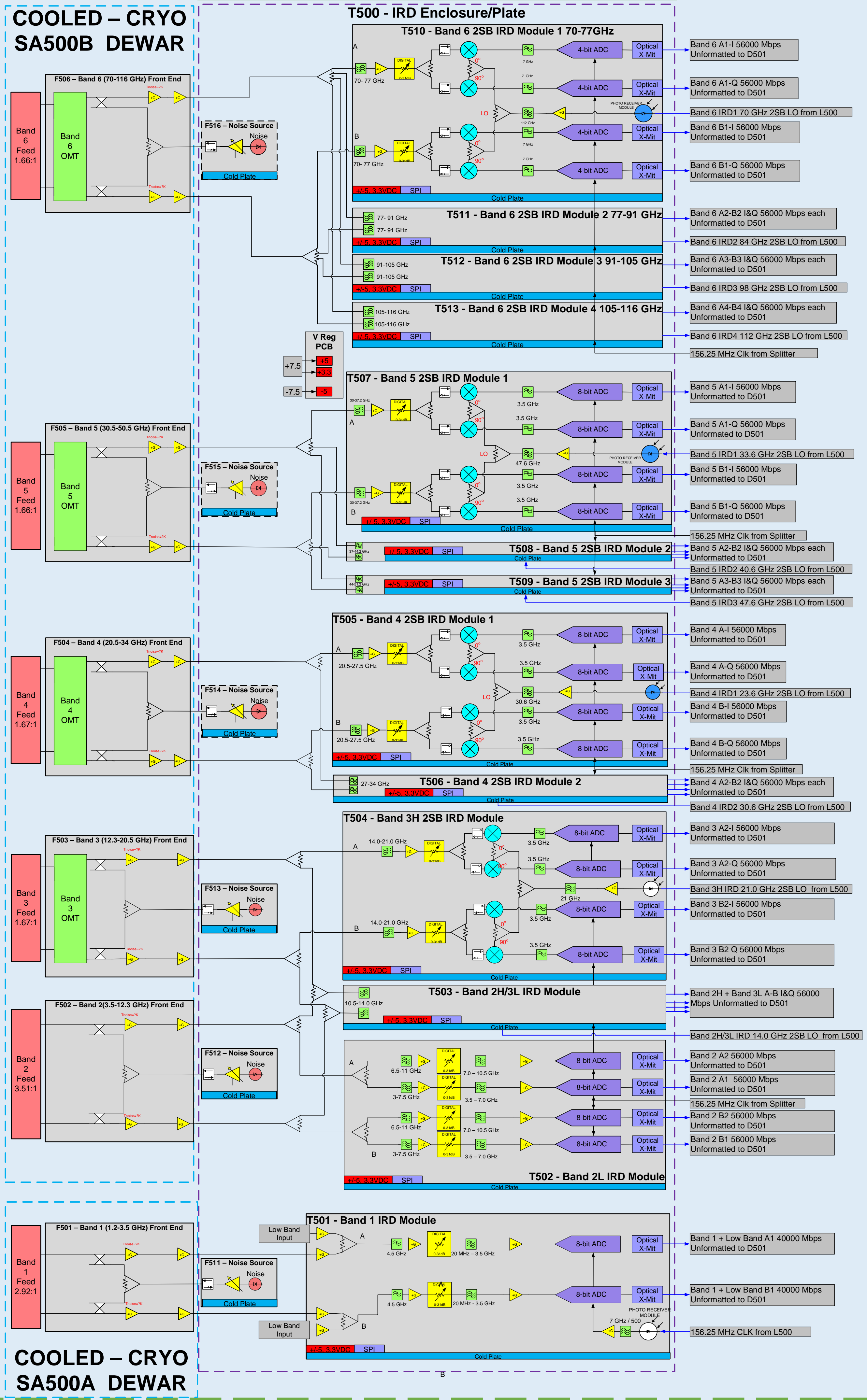

Receiver and I/Q Converter / Digitizer System

(Based on the proposed 6 band system as described in reference 1)

The basic concept is six cryogenically cooled feeds & receivers, mounted in two dewars, covering 1.2 to 116 GHz. The signals from these receivers are passed into small, integrated converter/digitizer modules being developed by Matt Morgan at the NRAO CDL. These devices, described in ngVLA memo 29, are based around a digitizer-serializer ASIC design. They will allow common, low cost, configurable modules to be integrated into the receiver package. The converter/digitizer modules will produce unformatted optical data streams to be sent off of the antenna to a local digital system at the base of the antenna, or directly to the array central signal processor.

Bands 1-5 utilize the digitizers in their 8 bit 7 GS/s mode. Sky frequencies from 1.2 to 10.5 GHz are direct sampled. Sky frequencies from 10.5 to 50 GHz are downconverted and split into IQ pairs by sideband separating mixers, then digitized in IQ pairs.

Bands 4-6 utilize the digitizers in their 4-bit 14 GS/s mode. Observable sky frequencies from 70 to 116 GHz are direct downconverted to baseband and split into IQ pairs by sideband separating mixers, then digitized as IQ pairs.

This system reduces the risk of LO tones polluting the signal path as is common in multiple conversion systems. Additionally, its simplicity ensures high gain and phase stability.

Digital Processing & Transmission

The unformatted data streams from the ADCs are optically combined onto a smaller number of fibers (not shown). Band selection is accomplished by turning on the transmitters only for the band in use. At the base of the antenna, or the array center, the fibers from the combiners are fed into optical receivers. The outputs of the receivers are fed into clock recovery and aligner circuitry, digitally processed and/or re-formatted for long haul transmission to the correlator at the array center for final processing. This multi-step process simplifies the digital electronics and minimizes the number of RF or fiber switches in the antenna. It also provides single dish data quality heuristics to monitor the system health and data integrity.

Local Oscillator/Reference System

The electronics at the base of the antenna receive a 512 MHz CW tone and/or digital timing signal from the array center or a remote LO/timing station. The round trip phase can be measured between the antenna and the source. These signals are used to lock a crystal oscillator and timing generator logic. Local Oscillator and ADC clocks are generated from these references by basic PLL synthesizers, modulated onto fiber and sent to the front end electronics. Round trip phase of the fiber going up the antenna is also measured. This well established technique provides low jitter clock and LO signals to the ADCs and mixers. The number of widely tuneable synthesizers is minimized to reduce cost & complexity and maximize system reliability.

References

- 1 - J. Jackson, R. Selina, *ngVLA Antenna Electronics - Front End Enclosure and Pesstal Block Diagrams* v2 (04/27/2018)
- 2 - W. Grammer, *ngVLA Band Configs v4.2* (12/13/2017)
- 3 - M. Morgan, S. Wunduke, *ngVLA Memo 29: An Integrated Receiver Concept for the ngVLA* (11/06/17)

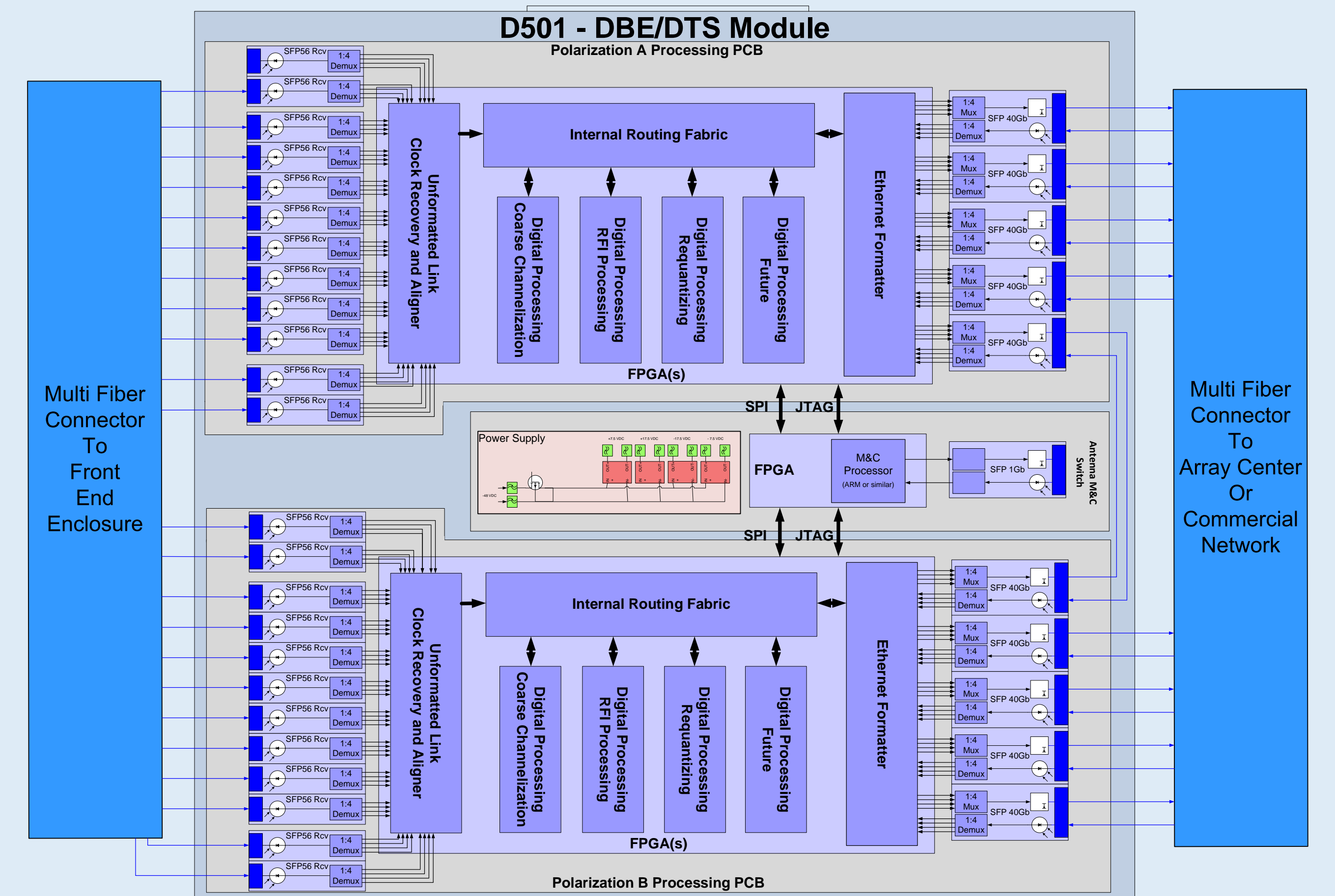

Digital Back End / Data Transmission System

Frequency Reference Recovery & Generation

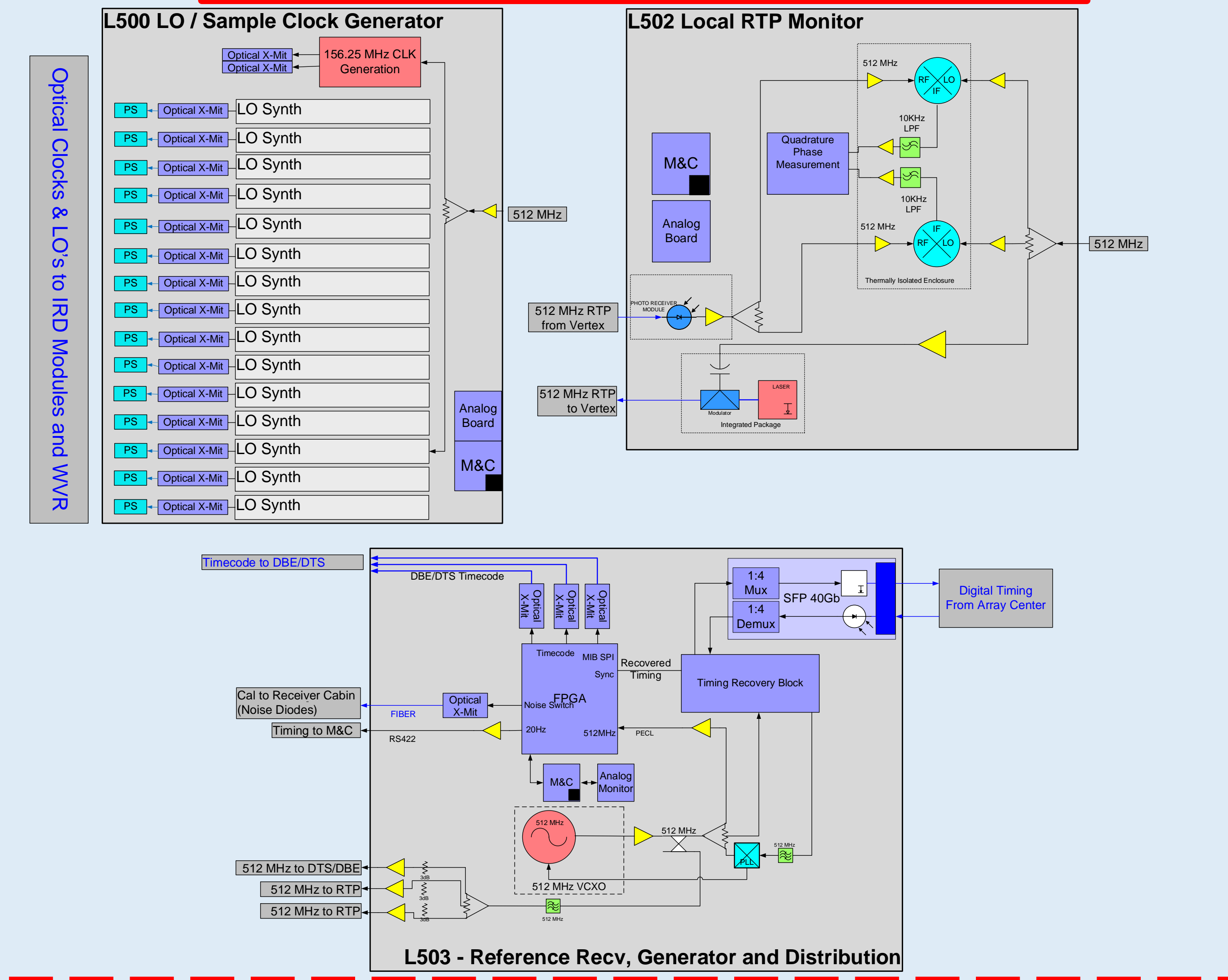

The National Radio Astronomy Observatory is a facility of the National Science Foundation operated under cooperative agreement by Associated Universities, Inc.

