



Title: Antenna Electronics Environmental Control Conceptual Design Description	Author: S. Sturgis	Date: 2024-03-14
NRAO Doc. #: 020.30.60.00.00-DSN		Version: C







Antenna Electronics Environmental Control Conceptual Design Description

020.30.60.00.00-0002-DSN-C

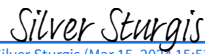
Status: **Released**

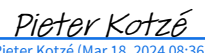
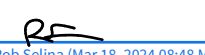
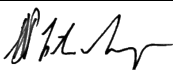
PREPARED BY	ORGANIZATION	DATE
S. Sturgis, J. Allison, C. Bryant	Electronics Div., NRAO	2024-03-14

APPROVALS	ORGANIZATION	SIGNATURES
S. Sturgis, Mechanical Engineer	ngVLA, NRAO	 <small>Silver Sturgis (Mar 15, 2024 15:53 MDT)</small>
P. Lopez, Antenna Electronics IPT Lead	ngVLA, NRAO	 <small>Phillip Lopez (Mar 18, 2024 08:30 MDT)</small>
P. Kotzé, Systems Engineer	ngVLA, NRAO	 <small>Pieter Kotzé (Mar 18, 2024 08:36 MDT)</small>
R. Selina, Project Engineer	ngVLA, NRAO	 <small>Rob Selina (Mar 18, 2024 08:48 MDT)</small>
W. Esterhuysen, Project Manager	ngVLA, NRAO	

RELEASED BY	ORGANIZATION	SIGNATURES
W. Esterhuysen, Project Manager	ngVLA, NRAO	



Title: Antenna Electronics Environmental Control Conceptual Design Description	Author: S. Sturgis	Date: 2024-03-14
NRAO Doc. #: 020.30.60.00.00-DSN		Version: C

Change Record

Version	Date	Author	Affected Section(s)	Reason
B	2022-04-25	S. Sturgis, J. Allison, C. Bryant	All	Initial Draft
B	2022-06-01	S. Sturgis	All	Updated per RIDS responses
C	2023-03-14	S. Sturgis	All	ECR-0002 update due to EEC Chiller responsibility transfer to mtex



Title: Antenna Electronics Environmental Control Conceptual Design Description	Author: S. Sturgis	Date: 2024-03-14
NRAO Doc. #: 020.30.60.00.00-DSN		Version: C

Table of Contents

1	Introduction.....	4
1.1	<i>Purpose and Scope.....</i>	4
2	Related Documents and Drawings	4
2.1	<i>Applicable Documents.....</i>	4
2.2	<i>Reference Documents.....</i>	4
3	Subsystem Overview	5
3.1	<i>High level description</i>	5
3.2	<i>Design Driving Requirements</i>	9
3.3	<i>Limits to Operating Conditions.....</i>	10
3.4	<i>Key risks.....</i>	11
3.4.1	Glycol Temperature Stability	11
3.4.2	Glycol Leakage.....	11
3.4.3	Glycol System Pressure.....	11
3.5	<i>Design assumptions.....</i>	11
3.5.1	Glycol Usage	11
3.5.2	Precision Temperature Stability	11
3.5.3	Commercial Cold Plates	12
4	Environmental Control Design	12
4.1	<i>Subsystem boundary, context, external interfaces, and product breakdown.....</i>	12
4.2	<i>Product design.....</i>	14
4.2.1	Glycol Chiller.....	14
4.2.2	Flow Control	15
4.2.3	Glycol Piping and Tubing.....	16
4.2.4	Liquid Cold Plates.....	17
4.2.5	Glycol Quick-Connect Couplers	18
4.2.6	Dry Air System.....	19
4.2.7	Front End Enclosure.....	20
4.2.8	Auxiliary Enclosure.....	22
4.2.9	Water Vapor Radiometer	23
4.2.10	Cryogenics Equipment.....	24
4.2.11	Electronics Rack.....	26
4.3	<i>Performance budgets.....</i>	28
4.3.1	Cold Plates	28
4.3.2	Flow Rate and Pressure Drop	29
4.4	<i>Reliability, Availability and Maintainability.....</i>	32
4.5	<i>Technology Readiness Assessment.....</i>	33
5	Appendix A: Trade Studies	34
5.1	<i>Air-cooled vs direct glycol cooled rack equipment.....</i>	34
6	Appendix B: Abbreviations and Acronyms	36



Title: Antenna Electronics Environmental Control Conceptual Design Description	Author: S. Sturgis	Date: 2024-03-14
NRAO Doc. #: 020.30.60.00.00-DSN		Version: C

1 Introduction

1.1 Purpose and Scope

The purpose of this document is to describe the conceptual design of the Electronics Environmental Control subsystem (EEC) for the ngVLA 18m antenna. It covers the design approach, description of key components, and risks associated with the conceptual design. This document will form part of the ngVLA Design documentation package.

The scope of this document covers the entire design of the Electronics Environmental Control subsystem, how it functions, and its interfaces with other subsystems. This document does not cover budgetary information, and the specific technical requirements can be found in AD16.

2 Related Documents and Drawings

2.1 Applicable Documents

The following documents may not be directly referenced herein, but provide necessary context or supporting material.

Ref. No.	Document Title	Rev/Doc. No.
AD01	ngVLA System Requirements	020.10.15.10.00-0003-REQ
AD02	LI System Environmental Specifications	020.10.15.10.00-0001-SPE
AD04	Main Antenna Electronics Block Diagrams	020.30.00.00.00-0005-BLK
AD05	IRD to EEC ICD	020.10.40.05.00-0003-ICD
AD06	FED to EEC ICD	020.10.40.05.00-0017-ICD
AD07	WVR to EEC ICD	020.10.40.05.00-0024-ICD
AD08	CRY to EEC ICD	020.10.40.05.00-0045-ICD
AD09	HIL / MCL to EEC ICD	020.10.40.05.00-0066-ICD
AD10	RTD to EEC ICD	020.10.40.05.00-0069-ICD
AD11	ATF to EEC ICD	020.10.40.05.00-0070-ICD
AD12	DBE to EEC ICD	020.10.40.05.00-0127-ICD
AD13	Interface Control Document: Antenna to Antenna Electronics	020.10.40.05.00-0011-ICD
AD14	ngVLA System Electronics Specifications	020.10.15.10.00-0008-REQ
AD15	WVR Conceptual Design Description	020.45.00.00.00-0002-DSN
AD16	EEC Requirements Specification	020.30.60.00.00-0001-REQ
AD17	Antenna and Equipment HVAC Specification	1021006-SPE-21-00000-001
AD18	Combined Antenna Power Budget Analysis	1021006-ANA-21-00000-005

2.2 Reference Documents

The following documents are referenced within this text:

Ref. No.	Document Title	Rev/Doc. No.
RD01		
RD02		



Title: Antenna Electronics Environmental Control Conceptual Design Description	Author: S. Sturgis	Date: 2024-03-14
NRAO Doc. #: 020.30.60.00.00-DSN		Version: C

3 Subsystem Overview

3.1 High level description

The Antenna Electronics is comprised of various equipment located in a number of places around the antenna with the primary equipment being the Front End Enclosure, the Auxiliary Enclosure, the FE Cable Carrier, the Electronics Rack, the Cryogenics Equipment, and the Water Vapor Radiometer (WVR) (Figure 1). Antenna Electronics Environmental Control (EEC) is responsible for the temperature and humidity control of all the electronics in these locations.

The primary temperature control system is a chilled (or heated as necessary) liquid glycol loop which runs from a glycol chiller to each of the Antenna Electronics locations. The glycol chiller will be used to regulate the temperature of both the NRAO delivered Antenna Electronics as well as the mtex Antenna drive components (Figure 2). Antenna Electronics located above the azimuth bearing will be cooled via propylene glycol passing through liquid cold plates. Antenna electronics located below the azimuth bearing will be cooled via forced air, which is in turn chilled by a propylene glycol loop. Implementation details of the cooling of the mtex drive components are beyond the scope of this document.

All heat transferred to the glycol chiller from the cooling loops will be dissipated outside of the pedestal via an outdoor condenser. The outdoor condenser will most likely be located outside the radius of the feedarm in order to keep exhausted heat away from the pedestal and/or antenna back up structure as it may produce localized heating of the pedestal which can cause pointing errors.

To ensure that the cooling system is properly integrated with the antenna's design and operation, the Prototype antenna contractor (mtex) is providing the design and installation of the chiller and the fixed glycol distribution lines.

Title: Antenna Electronics Environmental Control Conceptual Design Description	Author: S. Sturgis	Date: 2024-03-14
NRAO Doc. #: 020.30.60.00.00-DSN		Version: C

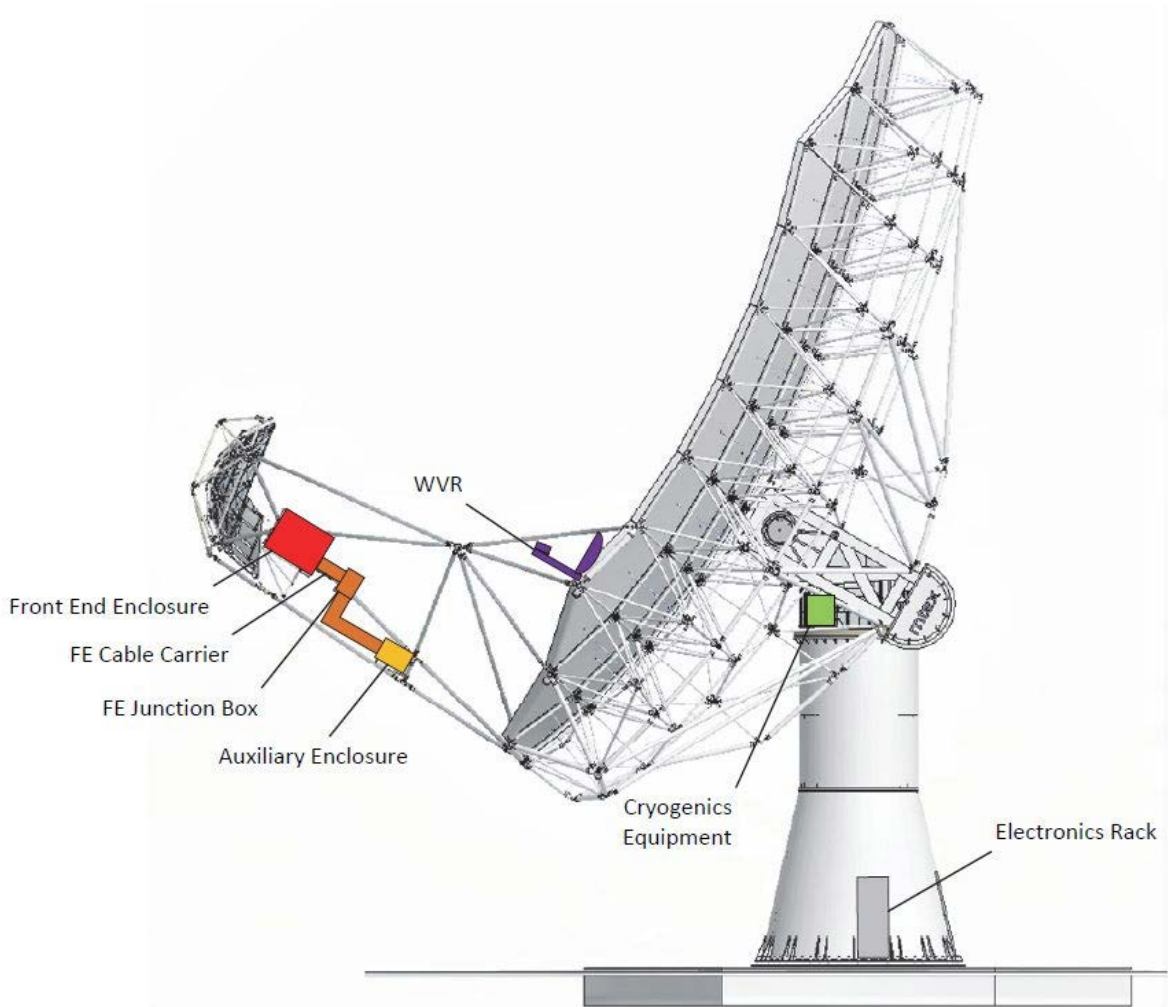

Figure 1. Antenna Electronics Primary Locations

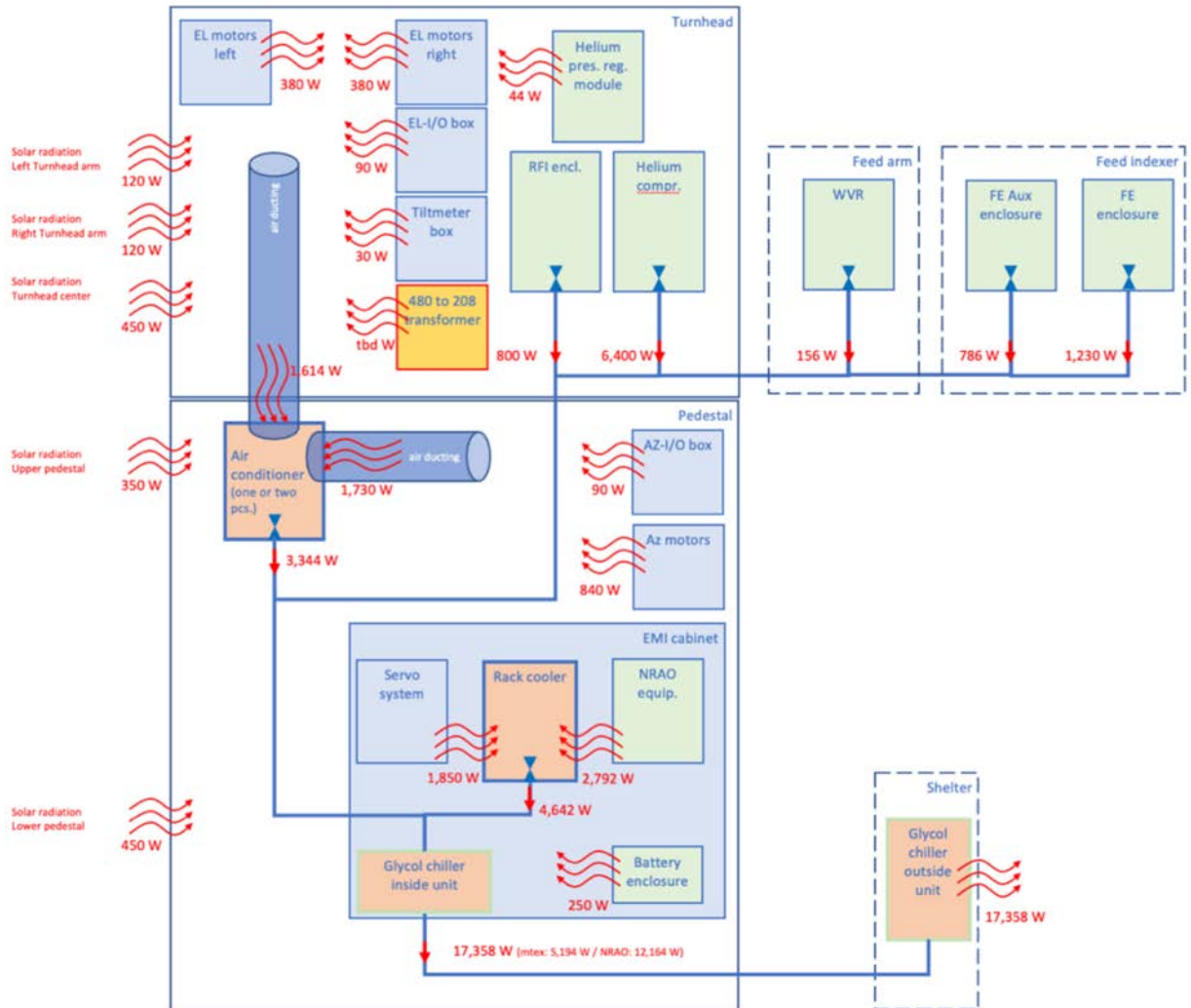

Figure 2. Block Diagram of mtex Plus Antenna Electronics Heat Loads

An overview of the products EEC will supply for each Antenna Electronics location is listed below.

The Front End Enclosure resides on the feed-arm at the secondary focus. The EEC subsystem shall provide the cold plates needed to cool the various electronics modules and the dry air system that will control the inside humidity level. The temperature stability requirement of some electronics modules or subassemblies might require the flow to be adjusted, proportional solenoid valves with control loops will then be required. EEC shall provide:

- Glycol lines from antenna provided pipe to Front End enclosure
- Glycol lines internal to the cable carrier
- Glycol lines internal to Front End Enclosure
- Liquid to air heat exchanger with fan
- Cold plate, SA501 Bands 5-6 IRD/LO Module
- Cold plate, SA502 Bands 1-4 IRD/LO Module
- Cold plate, L501 Main LO Module



Title: Antenna Electronics Environmental Control Conceptual Design Description	Author: S. Sturgis	Date: 2024-03-14
NRAO Doc. #: 020.30.60.00.00-DSN		Version: C

- Cold plate, M507 Utility Module
- Dry air system to control humidity
- Flow control valves
- Flow control valve drive electronics

The Auxiliary Enclosure resides on the feed arm between the Front End Enclosure and the Primary Reflector. At this location the EEC subsystem shall provide:

- Glycol lines from antenna provided pipe end to Auxiliary enclosure
- Glycol lines internal to Auxiliary Enclosure
- Liquid to air heat exchanger with fan
- Cold plate, M506 Utility Module
- Cold plate, F521 Cold Head VFD Driver Module
- Cold plate, F523 VFD Control Module
- Flow control valves
- Drive electronics for the flow control valves
- Cold plate for Vacuum pump (TBD)

The Water Vapor Radiometer is located on the edge of the primary reflector and consists of a parabolic reflector with a dedicated Front End Receiver Module at the focus, and a Utility Module located behind the dish (or another suitable location close by). Each module will be within an environmental enclosure to protect it from the weather. The WVR has a very tight requirement for temperature stability that will require the flow of the glycol loop to be controlled. The EEC subsystem shall provide:

- Glycol lines from antenna provided pipe end to WVR
- Glycol piping internal to the WVR subsystem
- Cold plate, F507 WVR Receiver Module
- Cold plate, M508 WVR Utility Module
- Flow control valve
- Drive electronics for the flow control valve

The Cryogenics Equipment is located in the Antenna Turn Head, and is made up of two primary components, the Helium Compressor and the Cryogenics RF Enclosure. The dry air system will also be located in the Antenna Turn Head. The EEC subsystem shall provide:

Fixed EEC components provided by Antenna:

- Glycol pipes with shut off valves near to the Helium Compressor and the Cryogenics RFI Enclosure
- Turn head air ducts
- Blowers to circulate the air
- Distribution manifold
- Flow control valves
- Glycol piping

EEC components provided by Antenna Electronics:

- Glycol lines from antenna provided pipe end to helium compressor and Cryo RFI enclosure
- Glycol lines internal to Cryo RFI enclosure
- Cold plate, M505 Utility Module
- Cold plate, Helium Compressor VFD Module
- Cold plate, Helium Pressure Regulator Electronics Module (TBD)



Title: Antenna Electronics Environmental Control Conceptual Design Description	Author: S. Sturgis	Date: 2024-03-14
NRAO Doc. #: 020.30.60.00.00-DSN		Version: C

- Flow control Valve (TBD)
- Drive electronics for the flow control valve
- Dry air controller
- Glycol connecting lines between antenna provided pipes and Antenna Electronics equipment

The Electronics Rack is located in the Antenna Pedestal RFI Shielded Room and is forced air cooled by a co-located air handler. The EEC subsystem shall provide:

Fixed EEC components provided by Antenna:

- Pedestal air conditioner
- Pedestal air ducts up to the Electronics Rack
- Blowers to circulate the air
- EMI cabinet room Air Handler
- Glycol pipes to Air Handler
- Glycol pipes to distribution manifold in the turn head

EEC components provided by Antenna Electronics:

- Electronics Rack internal air ducting
- Electronics Rack internal air flow baffles

3.2 Design Driving Requirements

The driving requirements for the EEC sub-system originate primarily from the System Environmental Specifications (AD02), Antenna to Antenna Electronics ICD (AD17), and all of the ICD's between EEC and the other Antenna Electronics Subsystems (AD09-AD16). A subset of the key requirements that drive the design are shown in Tables 1-7 below.

Parameter	Summary of Requirement	Reference
Temperature Stability	The Antenna HVAC System design shall maintain a temperature stability of +/-1 °C/hr (TBC) at each of the Antenna Electronics locations.	EEC0002
Glycol temperature	The Antenna HVAC System design shall maintain the glycol supply between 5 °C and 10 °C.	EEC0003
Glycol Pump flow capacity	The Antenna HVAC System design shall be capable of pumping the required flow rates when the antenna is at the highest elevation (88 deg). The pump shall have a minimum flow capacity of TBD.	EEC0004
Glycol mixture	The proportion of propylene glycol to deionized water shall be 65/35	EEC0009
Life of the cooling system	The glycol chiller cooling system shall have a life expectancy of 30 year	EEC0010
MTBM	The subsystem shall have an MTBM of not less than 11905 hours.	EEC0011



Title: Antenna Electronics Environmental Control Conceptual Design Description	Author: S. Sturgis	Date: 2024-03-14
NRAO Doc. #: 020.30.60.00.00-DSN		Version: C

EMC/RFI Mitigation in Designs	RFI/EMC requirements shall be compliant with and tested per the ngVLA System EMC/RFI Mitigation Requirements.	EEC1150
Leak Protection	Any EEC equipment that can develop a leak of glycol shall have a way to collect or evacuate the liquid to prevent personnel injury or damage to other equipment	EEC0717
Component Maintainability	All component manufacturers shall support their equipment and have sufficient spare parts inventory for the design life of the instrument (30 years).	EEC0560

Table 1: Key Glycol Requirements.

3.3 Limits to Operating Conditions.

The EEC subsystem shall remain operational when other systems on the antenna are placed in Stand-by. Therefore, the operational conditions are the following:

Standby Conditions.

Parameter	Req. #	Value
Solar Thermal Load	ENV0360	Exposed to full sun, 1200W/m ²
Wind	ENV0361	0 m/s ≤ W ≤ 30 m/s average
Temperature	ENV0362	-25 C ≤ T ≤ 45 C
Precipitation	ENV0363	Up to 5 cm/hr over 10 mins
Ice	ENV0364	Equivalent to radial ice of 2.5 mm
Relative Humidity	ENV0365	0 ≤ RH ≤ 100%; condensation permitted
Standby Recovery Time	ENV0366	The system shall resume operation to specification within 5 minutes of conditions returning to the constraints of the Normal or Precision Operating Conditions.

Table 2. Standby Environmental Conditions

The survival conditions describe the environment that the antenna and all outside structures should be able to withstand without damage when placed in its least-vulnerable state. For the antenna, the designer will specify the orientation that will result in minimum stress to the structure at the maximum wind speed and maximum snow and ice loading. Systems housed within or on the antenna (including the environmental control system) shall assume this orientation.

The temperature limits, radial ice, snow load and hail stone requirements are based on experience at the VLA site and a survey of conditions throughout the extent of the array.

Survival Conditions.

Parameter	Req. #	Value
Wind	ENV0341	0 m/s ≤ W ≤ 50 m/s average
Temperature	ENV0342	-30 C ≤ T ≤ 52.5 C
Radial Ice	ENV0343	2.5 cm
Rain Rate	ENV0344	16 cm/hr over 10 mins



Title: Antenna Electronics Environmental Control Conceptual Design Description	Author: S. Sturgis	Date: 2024-03-14
NRAO Doc. #: 020.30.60.00.00-DSN		Version: C

Parameter	Req. #	Value
Snow Load, Antenna	ENV0345	25 cm
Snow Load, Equipment & Buildings	ENV0346	100 kg/m ² on horizontal surfaces
Hail Stones	ENV0347	2.0 cm
Antenna Orientation	ENV0348	Stow-survival, as defined by antenna designer

Table 3. Survival Environmental Conditions

3.4 Key risks

3.4.1 Glycol Temperature Stability

Glycol cooling and heating systems are generally fairly temperature stable, and achieving +/- 1 deg C is generally not a problem. However, the long pipe lengths from the glycol chiller to the various loads as well as the length of pipe exposed to the environment have the potential to decrease the temperature stability of the glycol.

3.4.2 Glycol Leakage

Glycol leakage is often a problem with glycol systems. Careful design and implementation are required to minimize the risks of system leaks. EEC will include fluid capture and containment provisions for all lines and locations that EEC is responsible for.

3.4.3 Glycol System Pressure

The glycol system is required to deliver glycol to all Antenna Electronics locations at the required flow rates. The Front End and the Auxiliary enclosures are located on the feed arm, and when the Antenna is pointing at the maximum 88 deg elevation the Front End and Auxiliary are at a significantly greater height than when the Antenna is pointing at the minimum elevation of 12 deg. This results in a significant system pressure requirement for the pump. Additionally, many components in each Antenna Electronics location will use valves for flow control as well as quick connects to allow individual components to be disconnected from the system and replaced. The large number of valves and quick connects introduces significant pressure drops into the system, which when coupled with the height of the Front End and Auxiliary enclosures could result in a required system pressure higher than desirable.

3.5 Design assumptions

3.5.1 Glycol Usage

Glycol will be used for all cooling of feed arm located equipment due to superior thermal density vs air. Running air ducts out along the feed arm large enough for sufficient air flow is not practical. A Propylene glycol and water mixture will be used throughout as it is non-toxic. A mixture ratio of approximately 65% glycol to 35% water will be used to keep the water from freezing in the survival environmental conditions.

3.5.2 Precision Temperature Stability

Temperature stability for electronics outside of what the glycol system can supply (+/- 1 deg C, TBC),



Title: Antenna Electronics Environmental Control Conceptual Design Description	Author: S. Sturgis	Date: 2024-03-14
NRAO Doc. #: 020.30.60.00.00-DSN		Version: C

will not be provided by EEC and are the responsibility of the individual subsystem. Precision temperature stability may be achieved via a thermoelectric, or Peltier, device located between the glycol cold plate and the electronics requiring precision temperature stability.

3.5.3 Commercial Cold Plates

Commercially sourced cold plates will be used as there is a large selection available such that a suitable one can be found for each application.

4 Environmental Control Design

4.1 Subsystem boundary, context, external interfaces, and product breakdown

The EEC subsystem provides temperature and humidity regulation of the antenna electronics at the different locations on the antenna. The various components are shown in the decomposition in Figure 3 with components supplied by the antenna contractor indicated in blue.

Title: Antenna Electronics Environmental Control Conceptual Design Description	Author: S. Sturgis	Date: 2024-03-14
NRAO Doc. #: 020.30.60.00.00-DSN		Version: C

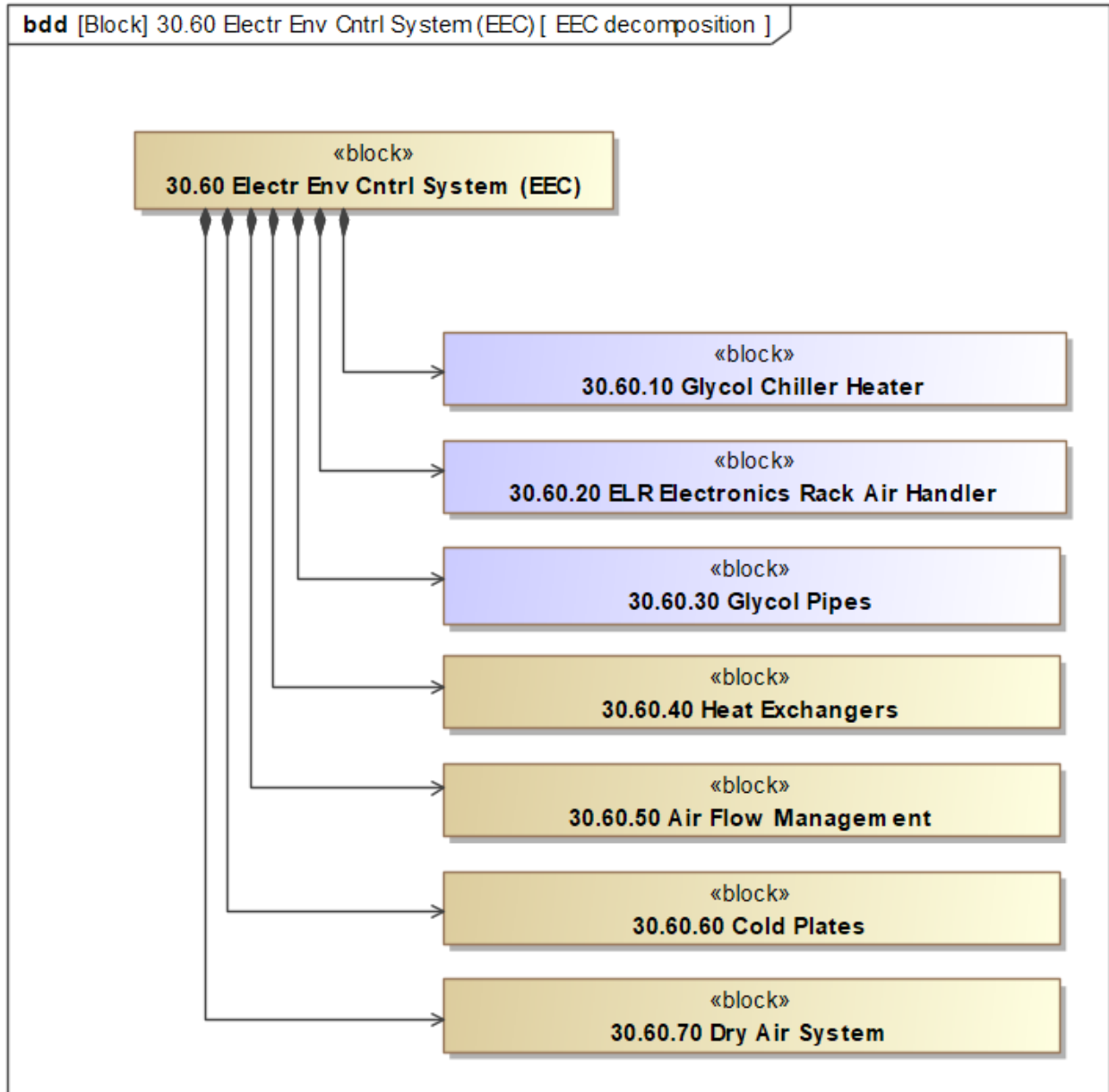

Figure 3. EEC decomposition

The external interfaces of EEC are shown in Figure 4 below. The EEC interfaces with:

- Antenna Electronics that are housed inside the modules/enclosures.
- Antenna: including mechanical interfaces to the glycol piping and AC power connections. Glycol lines internal to the Az and El wraps are responsibility of Antenna contractor..
- Antenna: shared use of the glycol chiller.

Title: Antenna Electronics Environmental Control Conceptual Design Description	Author: S. Sturgis	Date: 2024-03-14
NRAO Doc. #: 020.30.60.00.00-DSN		Version: C

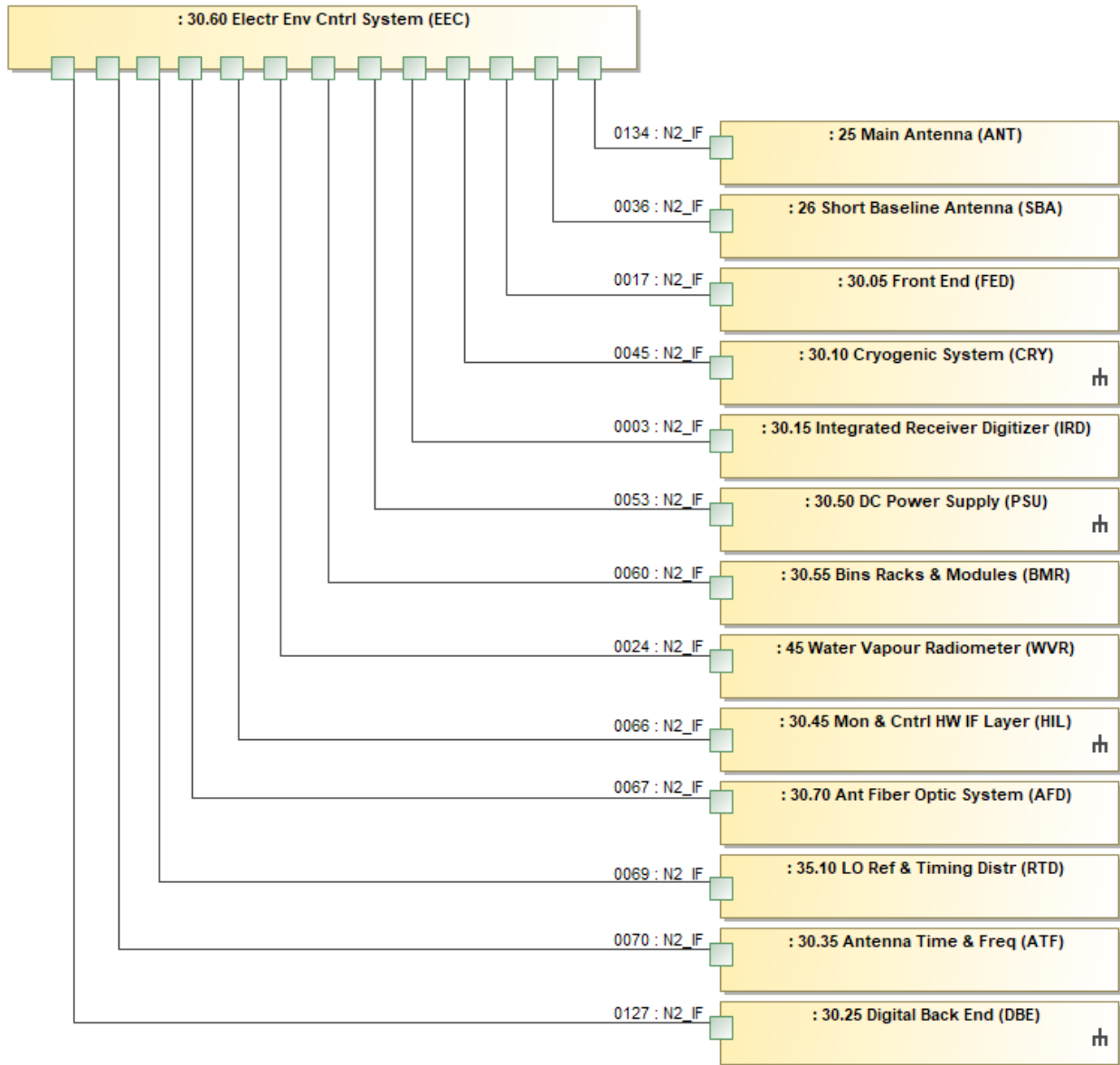

Figure 4. EEC External Interfaces

4.2 Product design

4.2.1 Glycol Chiller

The glycol chiller, delivered by the Antenna contractor, will regulate the temperature of all heat producing electronics on the antenna. The glycol chiller will supply temperature stable glycol to the entire antenna for all operating conditions and environments. The glycol chiller will be used to regulate the temperature of both the NRAO delivered Antenna Electronics as well as the mtex Antenna drive components. A full cooling system analysis is being performed by an mtex subcontractor, taking into account all of the requirements of both the Antenna Electronics as well as the mtex drive electronics.



Title: Antenna Electronics Environmental Control Conceptual Design Description	Author: S. Sturgis	Date: 2024-03-14
NRAO Doc. #: 020.30.60.00.00-DSN		Version: C

All heat transferred to the glycol chiller will be dissipated outside of the pedestal via an outdoor condenser, which is desirable as any heat exhausted near the structure may produce localized heating of the pedestal which can cause pointing errors.

The glycol used in the system will be propylene glycol due to its non-toxicity. The glycol will be mixed with water, with approximately 65% glycol to 35% water. The water has a higher heat capacity for transferring heat away from a heat source and the glycol keeps the water from freezing.

At a minimum, the M&C subsystem will need to know if the glycol chiller is functioning within spec or not. It is expected that the chiller sensors will be communicated with via the Antenna ACU.

4.2.2 Flow Control

The glycol flow control concept utilizes both manual valves and electronic proportional flow control valves (Figure 6). The Front End enclosure and the WVR will utilize an electronic proportional flow control valve that adjusts the total flow of glycol to that location. The other major Antenna Electronics locations may use an electronic proportional flow control valve as necessary, but it is not anticipated at this time. Each consumer of glycol (e.g. cold plate, heat exchanger, etc) will have a manual flow control valve that will be set such that the required flow of glycol is met for each piece of equipment in that location. Once all manual valves are set, the proportional flow control valves can regulate the flow, and the temperature of the equipment should all basically track together. The proportional flow control valves can also adjust the flow based on need or environmental conditions. The level of feedback and the required level of precision are TBD. The proportional flow control valves will most likely adjust flow rates based on monitored electronics temperatures. The glycol chiller will have a bypass valve in order to compensate for changing flow at each Antenna Electronics location.

For example, when a high heat load item and low heat load item are both in the same major location they will not require the same flow rate, so the manual valve on the high load item is set open enough to achieve the required flow rate and the manual valve on the low load item is set mostly closed to achieve a lower flow rate. As the environmental conditions change (temperature increase from direct sun, decrease at night, etc.), and the electronics either warm up or cool down, the proportional flow control valves can increase or decrease the flow as necessary to compensate.

The manual needle valves will be used for prototyping and system characterization but for production an inline restrictor or orifice plate may be used in order to reduce maintenance and eliminate the possibility of valves leaking.

Title: Antenna Electronics Environmental Control Conceptual Design Description	Author: S. Sturgis	Date: 2024-03-14
NRAO Doc. #: 020.30.60.00.00-DSN		Version: C



Figure 5. Proportional flow control valve (L) and Manual Needle valve (R)

4.2.3 Glycol Piping and Tubing

The EEC subsystem shall provide all glycol piping and tubing internal to all Antenna Electronics locations. Glycol piping and tubing necessary for Antenna Drive Electronics as well as glycol distribution from the chiller to each antenna electronics location shall be the responsibility of the antenna contractor.

Glycol piping internal to antenna electronics will be stainless steel or copper wherever rigid piping can be utilized, and a nitrile rubber hose with braided stainless steel jacket for the flexible sections (Figure 7). Insulation will be used wherever practical to help maintain stable glycol temperatures and to avoid condensation from forming on the lines.

All rigid piping will be securely mounted and accurately labeled . To minimize leakage, preference for rigid lines is to weld and form them wherever practical, and only use threaded fittings where absolutely necessary. Flexible lines are required in the Front End Cable Carrier.



Figure 6. Example of stainless-steel clad nitrile rubber hose

Title: Antenna Electronics Environmental Control Conceptual Design Description	Author: S. Sturgis	Date: 2024-03-14
NRAO Doc. #: 020.30.60.00.00-DSN		Version: C

4.2.4 Liquid Cold Plates

Antenna Electronics located above the azimuth bearing will be cooled via glycol passing through liquid cold plates. The cold plates will vary in requirements and size based on the equipment being cooled. The construction consists of an aluminum plate with milled grooves through which a continuous copper tube winds back and forth across the plate (Figure 9). The chilled glycol will run through the copper tubes, absorbing heat from the aluminum plate which will be bolted to the heat source via a series of mounting holes in the cold plate body between the copper tubes.



Figure 7. Example of a liquid cold plate on sample electronics

The majority of cold plates will be used on ARCS modules. ARCS modules are RFI shielded, and to preserve the high level of shielding the cold plates will be mounted to the exterior of the module (Figure 10). This configuration will increase the thermal resistance between the hot components and the cold plate, but preserving the RF shielding level is of paramount importance.

In order to avoid condensation forming on the cold plates, insulation will be added to the exterior of the cold plates. Desiccant can be added to the modules to avoid condensation forming in their interiors.

Title: Antenna Electronics Environmental Control Conceptual Design Description	Author: S. Sturgis	Date: 2024-03-14
NRAO Doc. #: 020.30.60.00.00-DSN		Version: C

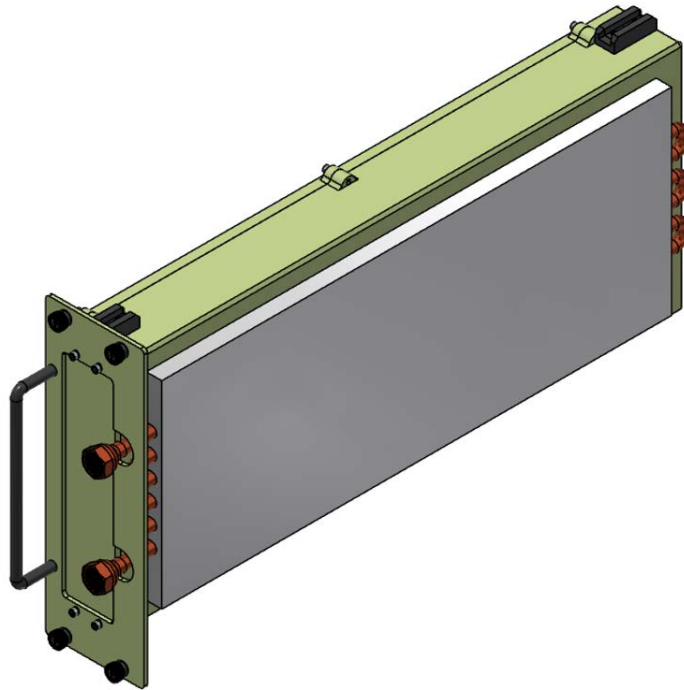

Figure 8. ARCS Module with cold plate, disconnected from the glycol system

4.2.5 Glycol Quick-Connect Couplers

Quick-Connect couplers will be used wherever cooled equipment will need to be removed or replaced in the field. They provide a quick and simple way to interrupt the cooling loop without shutting down the glycol system and purging the glycol lines at the desired disconnection point. The majority of cold plates and quick connects will be used on ARCS modules (Figure 11), as all ARCS modules are anticipated to be field replaceable.

It is very important that low-leakage quick connect couplers are selected to minimize the risk of spilling glycol on electronics and reduce the frequency of maintenance on the cooling system. Everis LQ Series couplers from CPC (www.cpcworldwide.com) will be used for the prototype antenna.

Title: Antenna Electronics Environmental Control Conceptual Design Description	Author: S. Sturgis	Date: 2024-03-14
NRAO Doc. #: 020.30.60.00.00-DSN		Version: C

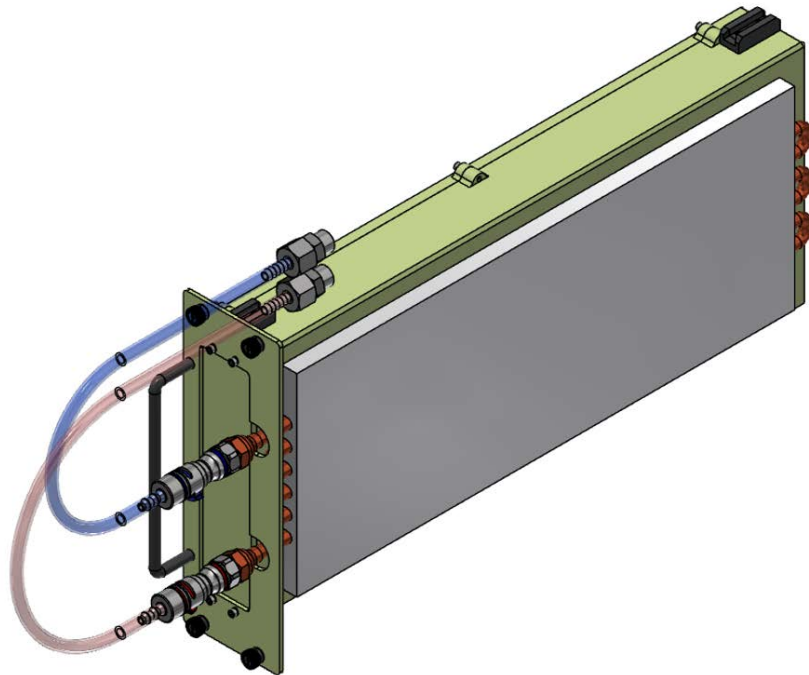

Figure 9. ARCS Module with cold plate, connected to the glycol system

The CPC Everis LQ Series couplers feature a chrome-plated brass body and EPDM seals specifically designed for minimizing leakage of glycol (Figure 13). The datasheet for these couplers claims a spillage of .025 - .055cc and an air inclusion of <.025cc per disconnect. These couplers have a maximum pressure of 120 psi and a temperature range of -17 to 115°C.



Figure 10. Everis LQ Series from CPC

4.2.6 Dry Air System

The Dry Air System will reside in the Antenna Turnhead and will consist of a self contained module that dries and circulates air via pipes and hoses to each enclosure requiring it. Details TBD.

Title: Antenna Electronics Environmental Control Conceptual Design Description	Author: S. Sturgis	Date: 2024-03-14
NRAO Doc. #: 020.30.60.00.00-DSN		Version: C

4.2.7 Front End Enclosure

The Front End Enclosure resides on the feed arm at the secondary focus, and houses Cryostats A and B, the Integrated Receivers and Downconverters, and parts of the Local Oscillator sub-system. At this location the EEC subsystem shall provide (Figure 14 and 15):

- Glycol lines from antenna provided pipe to Front End enclosure
- Glycol lines internal to the cable carrier
- Glycol lines internal to Front End Enclosure
- Liquid to air heat exchanger with fan
- Cold plate, SA501 Bands 5-6 IRD/LO Module
- Cold plate, SA502 Bands 1-4 IRD/LO Module

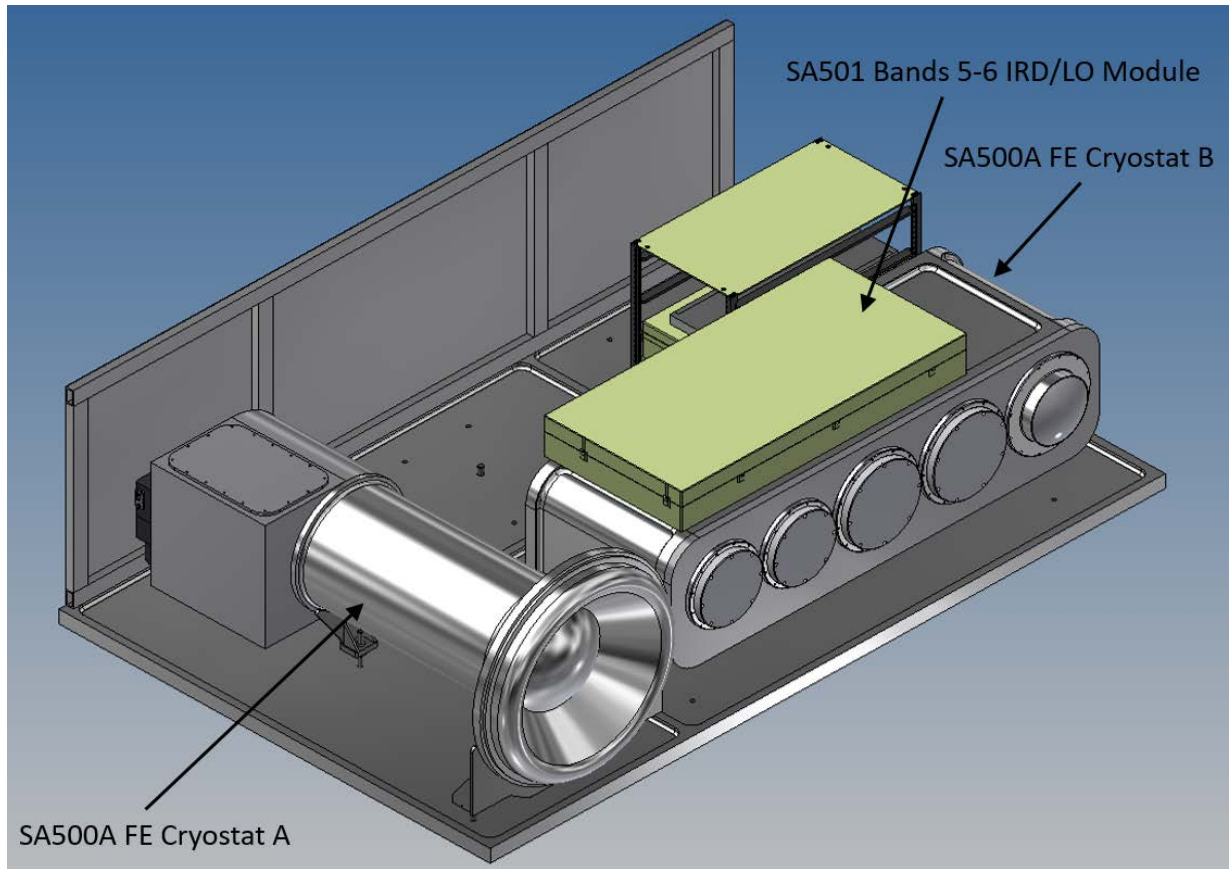

Figure 11. Populated FE Enclosure Overview, Cryostats and IRD/LO Enclosure

Title: Antenna Electronics Environmental Control Conceptual Design Description	Author: S. Sturgis	Date: 2024-03-14
NRAO Doc. #: 020.30.60.00.00-DSN		Version: C

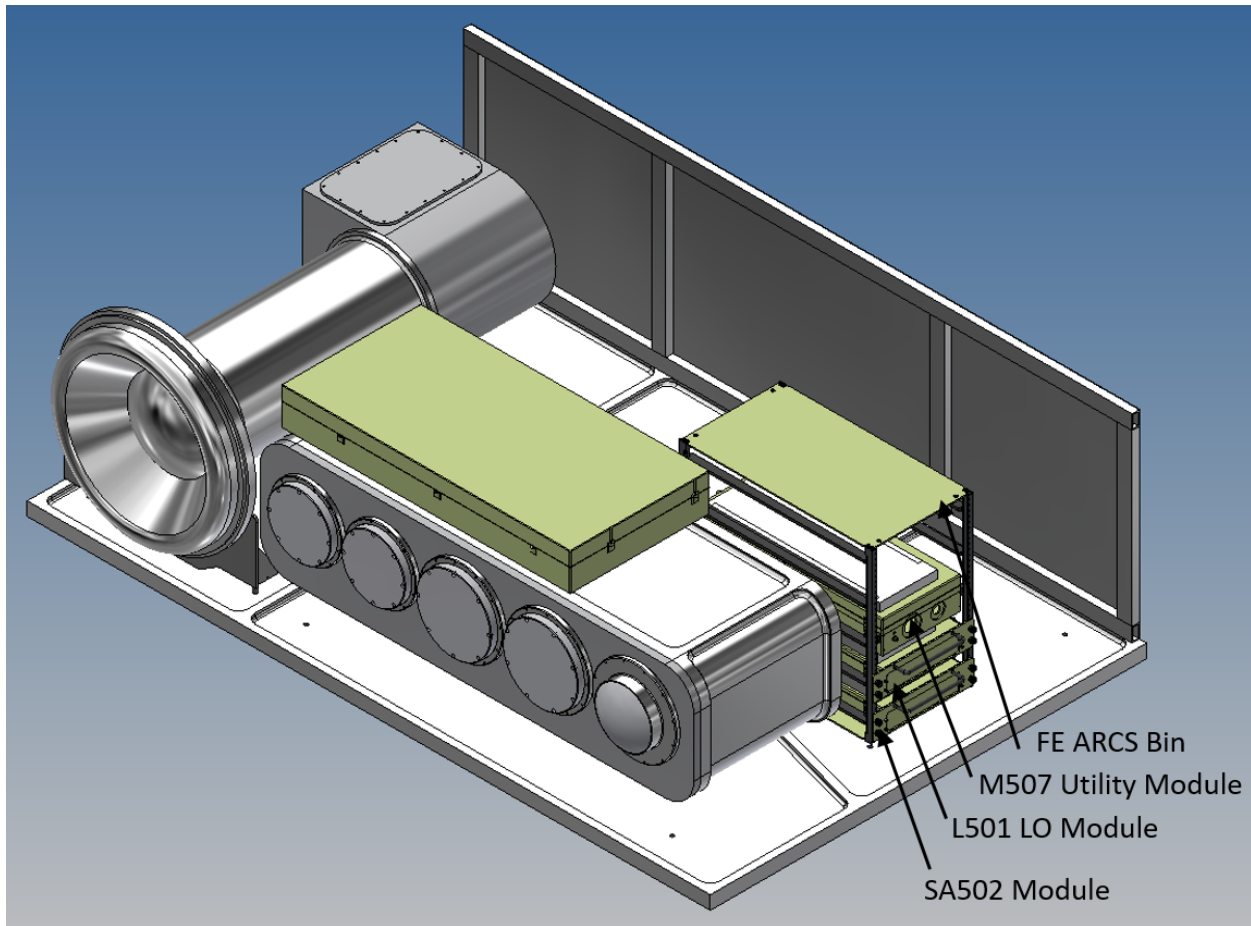

Figure 12. Populated FE Enclosure Overview, Bin and Modules Detail

The Front End Enclosure glycol lines will enter in the lower central section of the rear panel (Figure 14) and will be routed to each glycol consumer in parallel. This ensures that each component receives the same temperature of glycol.

The FE Enclosure will have a liquid to air heat exchanger with a fan to circulate the air and regulate the temperature in the enclosure. The details of the heat exchanger are TBD. The fan and heat exchanger are expected to increase the maintenance required, and as such eliminating them is highly desirable. Further investigation is needed to determine if the fan and heat exchanger can be eliminated.

There are four glycol cold plates in the FE Enclosure, one each for the SA501, SA502, L501, and M507. Specific cold plates have not been selected yet, and each one may be different due to different heat loads associated with each module.

The populated FE enclosure is considered to be an LRU as performing maintenance on most components must be done in a lab. The exceptions are the ARCS modules and the cryocoolers, both of which will be accessible for removal and replacement in the field.

Title: Antenna Electronics Environmental Control Conceptual Design Description	Author: S. Sturgis	Date: 2024-03-14
NRAO Doc. #: 020.30.60.00.00-DSN		Version: C

As a consequence of the FE enclosure being an LRU, all lines entering the enclosure must be able to be disconnected when the enclosure is removed from the antenna.

4.2.8 Auxiliary Enclosure

The Auxiliary Enclosure resides on the feed arm between the Front End Enclosure and the Primary Reflector. Figure 16 shows an overview of the Auxiliary Enclosure. At this location the EEC subsystem shall provide:

- Glycol lines from antenna provided pipe end to Auxiliary enclosure
- Glycol lines internal to Auxiliary Enclosure
- Liquid to air heat exchanger with fan
- Cold plate, M506 Utility Module
- Cold plate, F521 Cold Head VFD Driver Module
- Cold plate, F523 VFD Control Module
- Flow control valves
- Drive electronics for the flow control valves
- Cold plate for Vacuum pump (TBD)

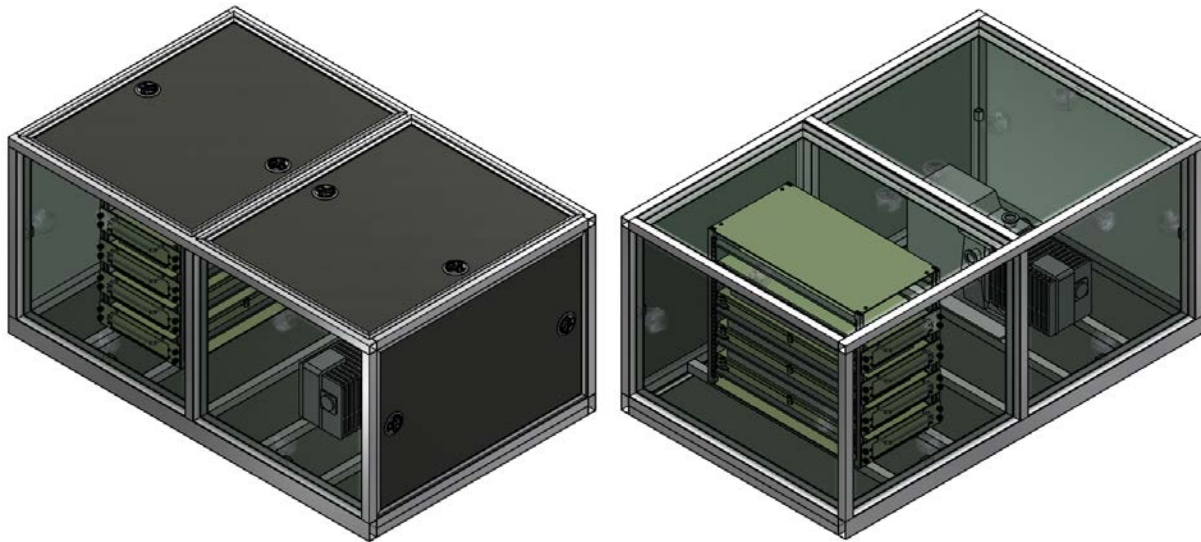

Figure 13. Auxiliary Enclosure Overview

The Auxiliary Enclosure glycol lines will be routed to each glycol consumer in parallel. This ensures that each component receives the same temperature of glycol.

The Auxiliary Enclosure will have a liquid to air heat exchanger with a fan to circulate the air and regulate the temperature in the enclosure. The details of the heat exchanger are TBD. The fan and heat exchanger are expected to increase the maintenance required, and as such eliminating them is highly desirable. Further investigation is needed to determine if the fan and heat exchanger can be eliminated.

There are up to five glycol cold plates in the Auxiliary Enclosure, one each for the M506, F521, F522 (if necessary), and F523 modules, and one for the F524 vacuum pump. Specific cold plates have not been



Title: Antenna Electronics Environmental Control Conceptual Design Description	Author: S. Sturgis	Date: 2024-03-14
NRAO Doc. #: 020.30.60.00.00-DSN		Version: C

selected yet, and each one may be different due to different heat loads associated with each module. The F524 may not end up being a cold plate if a suitable liquid cooled vacuum pump can be found.

The vacuum pump requires a minimum temperature of 12 deg C, which is greater than the minimum glycol temperature of 5 deg C. One possible solution is to have the vacuum pump cold plate in series with one or more of the module cold plates such that the glycol is heated by the module to above the 12 deg C minimum temperature required before being routed into the vacuum pump cold plate. Other solutions will also be investigated.

The F521 Cold Head VFD Driver module is located in the Auxiliary Enclosure, but the majority of its generated heat is dissipated in the Front End Enclosure.

4.2.9 Water Vapor Radiometer

The Water Vapor Radiometer is located on the edge of the primary reflector and consists of a parabolic reflector with a dedicated Front End Receiver Module at the focus, and a Utility Module located behind the dish (or another suitable location close by) (Figure 17). Each module will be within an environmental enclosure to protect it from the weather. The WVR has a very tight requirement for temperature stability that will require the flow of the glycol loop to be controlled. The WVR subsystem shall provide:

- Glycol lines from antenna provided pipe end to WVR
- Glycol piping internal to the WVR subsystem
- Cold plate, F507 WVR Receiver Module
- Cold plate, M508 WVR Utility Module
- Flow control valve

Title: Antenna Electronics Environmental Control Conceptual Design Description	Author: S. Sturgis	Date: 2024-03-14
NRAO Doc. #: 020.30.60.00.00-DSN		Version: C

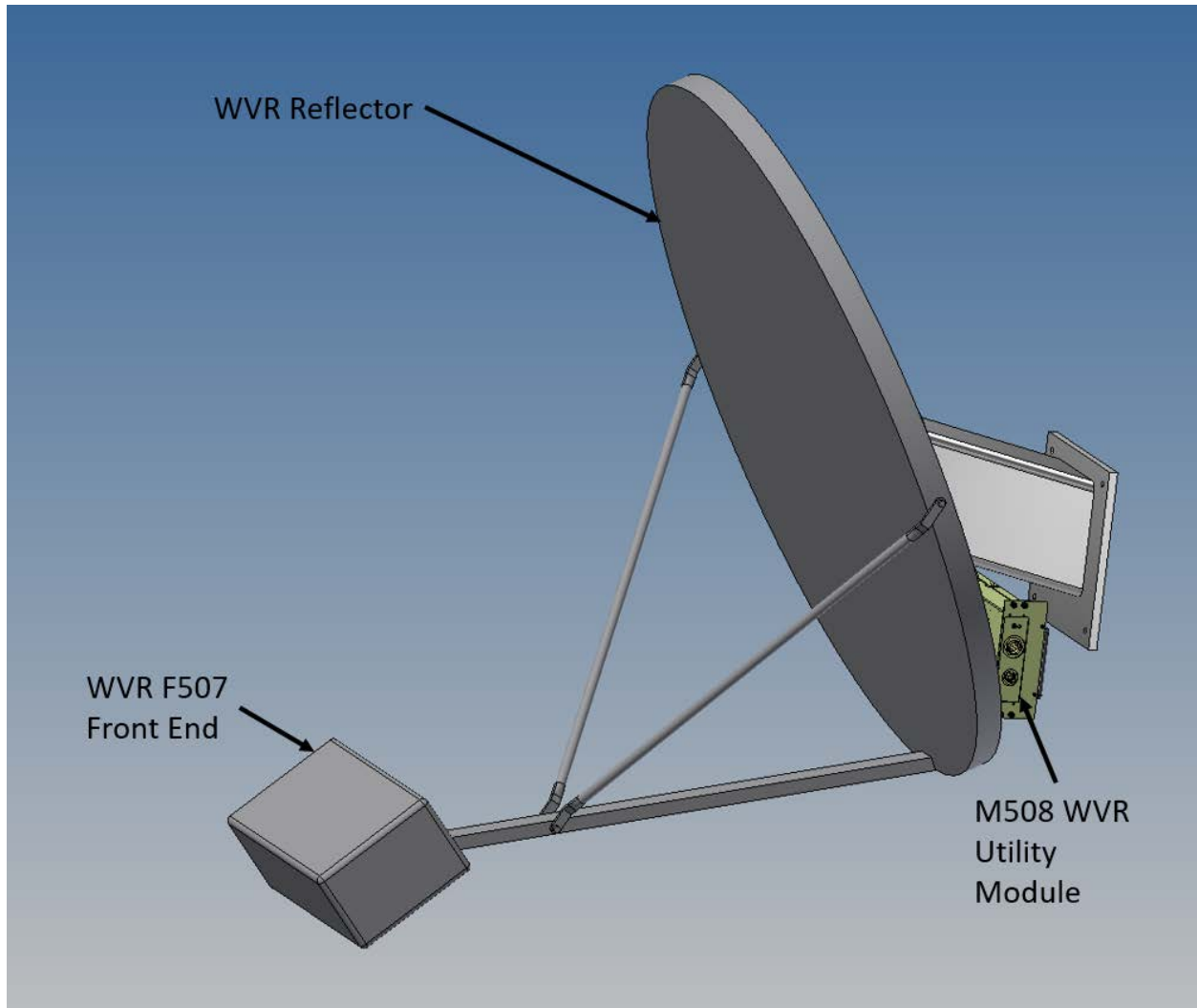

Figure 14. WVR Overview

The WVR glycol lines will be routed to each glycol consumer in parallel. This ensures that each component receives the same temperature of glycol.

There are two glycol cold plates in the WVR subsystem, one each for the M508, and F507 modules. Specific cold plates have not been selected yet, and each one is expected to be different due to different heat loads and physical size requirements associated with each module.

4.2.10 Cryogenics Equipment

The Cryogenics Equipment is located in the Antenna Turn Head, and is made up of the Helium Compressor and the Cryogenics RF Enclosure. The dry air system is also located in the Antenna Turn Head (Figure 18). The EEC subsystem shall provide:

- Glycol lines from antenna provided pipe end to helium compressor and Cryo RFI enclosure
- Glycol lines internal to Cryo RFI enclosure

Title: Antenna Electronics Environmental Control Conceptual Design Description	Author: S. Sturgis	Date: 2024-03-14
NRAO Doc. #: 020.30.60.00.00-DSN		Version: C

- Cold plate, M505 Utility Module
- Cold plate, Helium Compressor VFD Module
- Cold plate, Helium Pressure Regulator Electronics Module (TBD)
- Flow control Valve (TBD)
- Drive electronics for the flow control valve
- Dry air controller
- Glycol connecting lines between antenna provided pipes and Antenna Electronics equipment

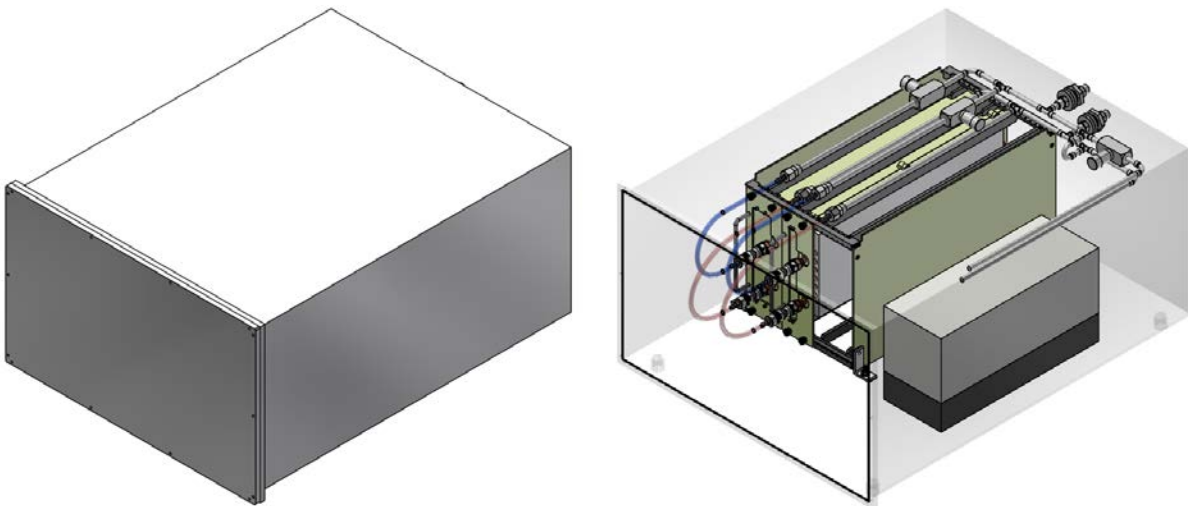

Figure 15. Cryogenics RF Enclosure

The Cryogenics equipment glycol lines will be routed to each glycol consumer in parallel. This ensures that each component receives the same temperature of glycol. There are two primary consumers of glycol, the Helium compressor and the Cryogenics RF Enclosure.

The Helium compressor is designed to be liquid cooled and does not require a dedicated cold plate.

There are three glycol cold plates in the Cryogenics RF Enclosure, one each for the M505, Helium Compressor VFD, and Helium Pressure Regulator Electronics modules (if necessary). Specific cold plates have not been selected yet, and each one is expected to be different due to different heat load requirements associated with each module.

The Helium Compressor VFD packaging is TBD. It may reside in a module and be cooled by a cold plate, or it may be mounted inside the Cryogenics RF Enclosure without a module and be directly cooled by glycol. Details TBD.

One design feature that has yet to be verified is the glycol line penetration into the RFI shielded enclosure. Glycol is conductive and the consequences of a conductive fluid penetrating an RFI shielded enclosure are not fully clear. RFI shielding requires a faraday cage, or conductive enclosure, which could



Title: Antenna Electronics Environmental Control Conceptual Design Description	Author: S. Sturgis	Date: 2024-03-14
NRAO Doc. #: 020.30.60.00.00-DSN		Version: C

be compromised by the glycol line penetration. For the ARCS modules this is accomplished by keeping the glycol lines outside of the RFI shielded volume. But if the glycol lines must penetrate the shielded volume as in the case of the Cryogenics RF Enclosure, the theory is to keep a metallic barrier between the conductive glycol and the RFI shielded volume. This is generally solved by using rigid metallic tubing where possible. However, the glycol line connection to the module must be flexible to support the quick connect style for easy change out of modules. One option is to use flexible metallic lines for the short sections near the quick connects. Another option is to use blindmate quick connects on the rear of the module which could be plumbed into rigid piping. Further investigation and testing is necessary to determine which option will work best.

4.2.11 Electronics Rack

The Electronics Rack is located in the Antenna Pedestal RF Shielded Room and is forced air cooled by a co-located air handler. The EEC subsystem shall provide:

- Electronics Rack internal air ducting
- Electronics Rack internal air flow baffles

4.2.11.1 Air Handler

There will be an air handler in the lower pedestal RF shielded room, provided by the Antenna contractor, that will force cooled air through the Electronics Rack to cool all rack contents. The air handler will utilize a liquid to air heat exchanger fed by the glycol system to cool the air.

The antenna drive electronics will also be located in the pedestal RF shielded room and will be air cooled. It may be practical to share an air handler between the Electronics Rack and the Antenna Drive Electronics. Discussions with the antenna contractor are ongoing to determine the best mutual solution. In either case, the air handler shall supply the maximum flow rate at the pressure drop specified in Table 13 to the Electronics Rack.

Air flow rate at Electronics Rack	The flow rate of air required at the Electronics Rack shall be <0.24 M ³ /s	EEC0071
Pressure drop at Electronics Rack	The static pressure drop for the airflow at the Electronics Rack is <500 Pa	EEC0072

Table 4. Air Handler flow rate and pressure drop requirements

4.2.11.2 Electronics Rack Air Flow

The Electronics Rack will be an EIA standard 19-inch rack, 42U tall (Figure 19), initially with a depth of 30 inches to reserve space in the event that direct glycol cooling of a high heat density rack mounted component is necessary, which requires more depth for the glycol fittings.

An electronics rack concept utilizing direct glycol cooling of all equipment was investigated, see Appendix A for more information.

The Electronics rack sits on top of a plenum box to allow forced air input to the bottom of the rack. The lower section of the rack houses all electronics packaged in ARCS modules and requires vertical air flow, while the upper section of the rack houses commercially packaged electronics that require front to rear air flow. The concept has forced air entering the bottom of the rack, and after passing through all of the ARCS modules it is directed into the space between the rack mounted components and the front

Title: Antenna Electronics Environmental Control Conceptual Design Description	Author: S. Sturgis	Date: 2024-03-14
NRAO Doc. #: 020.30.60.00.00-DSN		Version: C

door and then horizontally into the COTS equipment in the upper section of the rack, after which it then exits at the top of the rack (Figure 20). Careful arrangement of the ARCS modules may be necessary to optimize the cooling requirements of each one. Once additional details of each module are known, simulations can be performed and a specific arrangement of modules can be tested.

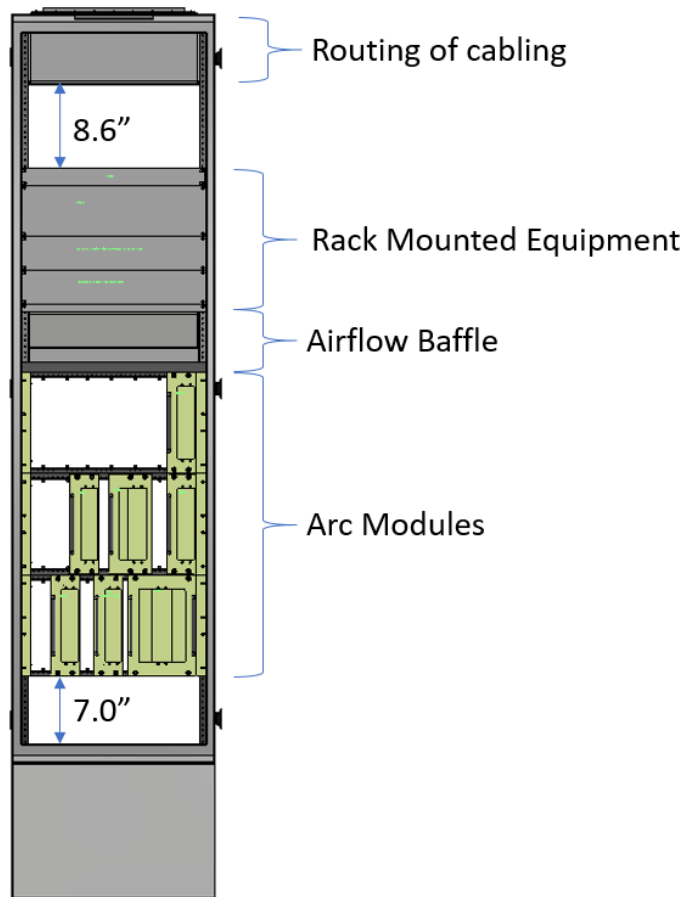

Figure 16. Electronics Rack Layout, front view

Title: Antenna Electronics Environmental Control Conceptual Design Description	Author: S. Sturgis	Date: 2024-03-14
NRAO Doc. #: 020.30.60.00.00-DSN		Version: C

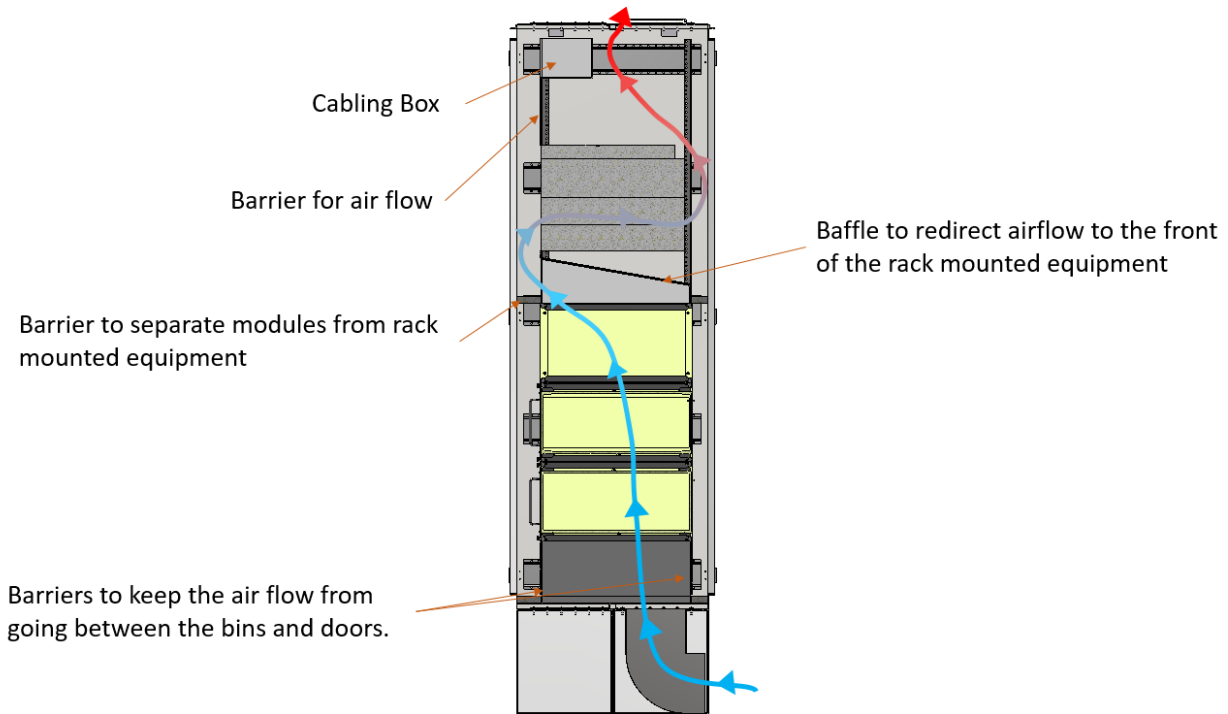

Figure 17. Electronics Rack Air Flow, side section view

4.3 Performance budgets

4.3.1 Cold Plates

The heat loads for each module cold plate by location are listed in Table 14.

The F521 Cold Head VFD Driver Module appears in both the FE and AUX locations. To clarify, there exists only a single F521 module, and it resides in the Aux, but much of its heat is dissipated in the FE enclosure hence the double listing.

The SA501, due to higher heat load spread over a larger area, will have either a single oversize cold plate, or multiple smaller cold plates depending on the layout of heat generating devices housed within. One deciding factor is which option would yield a smaller pressure drop across the cold plate or plates.

The F522 Vacuum Pump and Feed Heater Driver Module in the Aux, and the Helium Pressure Regulator Electronics Module in the Cryogenics RF Enclosure are not expected to produce much heat, if any, but they are included here in the case that they do end up requiring a cold plate.

The F524 Vacuum Pump located in the Aux may not end up utilizing a cold plate if a suitable liquid cooled vacuum pump can be found.



Title: Antenna Electronics Environmental Control Conceptual Design Description	Author: S. Sturgis	Date: 2024-03-14
NRAO Doc. #: 020.30.60.00.00-DSN		Version: C

The Helium Compressor VFD packaging is TBD. It may reside in a module and be cooled by a cold plate, or it may be mounted inside the Cryogenics RF Enclosure and be directly cooled by glycol. Details TBD.

Location	Cold Plate	Heat Load (Watts)
FE	SA501 Bands 5-6 IRD/LO Module	440
	SA502 Bands 1-4 IRD/LO Module	160
	L501 Main LO Module	50
	M507 Utility Module	147
	F521 Cold Head VFD Driver Module	208
Aux	M506 Utility Module	88
	F521 Cold Head VFD Driver Module	48
	F522 Vacuum Pump and Feed Heater Driver Module	TBD
	F523 VFD Control Module	50
	F524 Vacuum Pump	600
Cryogenics RF	M505 Utility Module	55
	Helium Compressor VFD Module	750
	Helium Pressure Regulator Electronics Module	TBD
WVR	F507 WVR Front End RFI Enclosure Module	85
	M508 Utility Module RFI Enclosure Module	71

Table 5. Cold Plate heat loads

4.3.2 Flow Rate and Pressure Drop

Preliminary piping diagrams of the glycol distribution, for each of the equipment locations that utilize glycol, have been developed and used to estimate the maximum pressure drop at the required flow rates (Figures 21 - 24). The resulting flow rates and pressure drops at each location are presented in Table 15. A more detailed analysis will be required to verify the piping and valve layouts presented here.

Title: Antenna Electronics Environmental Control Conceptual Design Description	Author: S. Sturgis	Date: 2024-03-14
NRAO Doc. #: 020.30.60.00.00-DSN		Version: C

FRONT END ENCLOSURE:

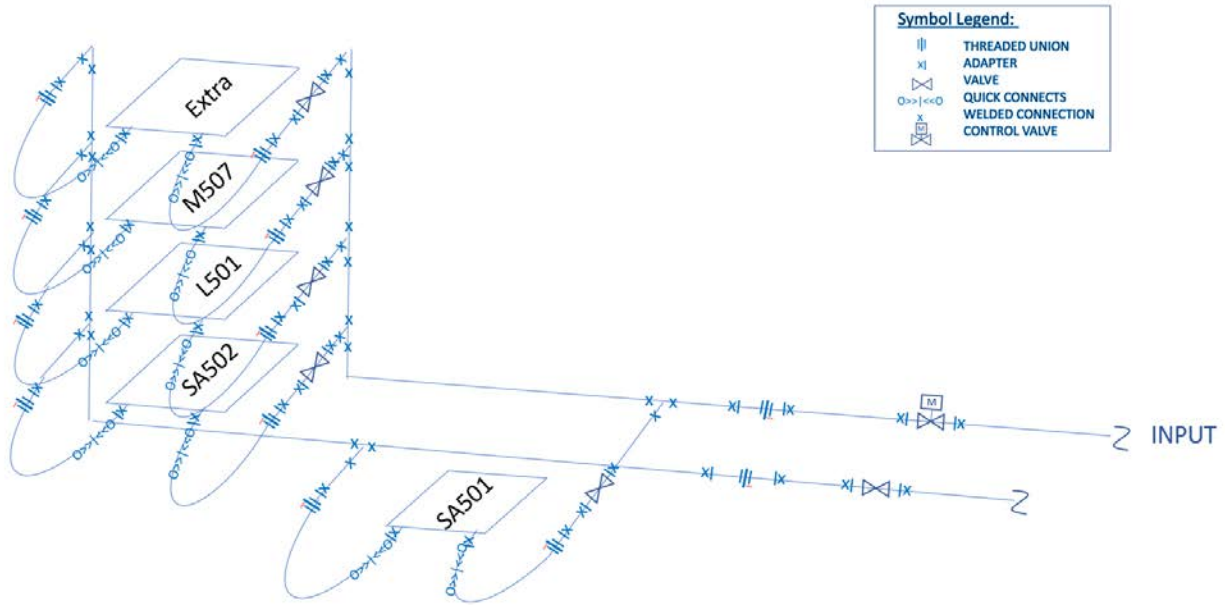

Figure 18. Front End Enclosure Piping Diagram

AUXILIARY ENCLOSURE:

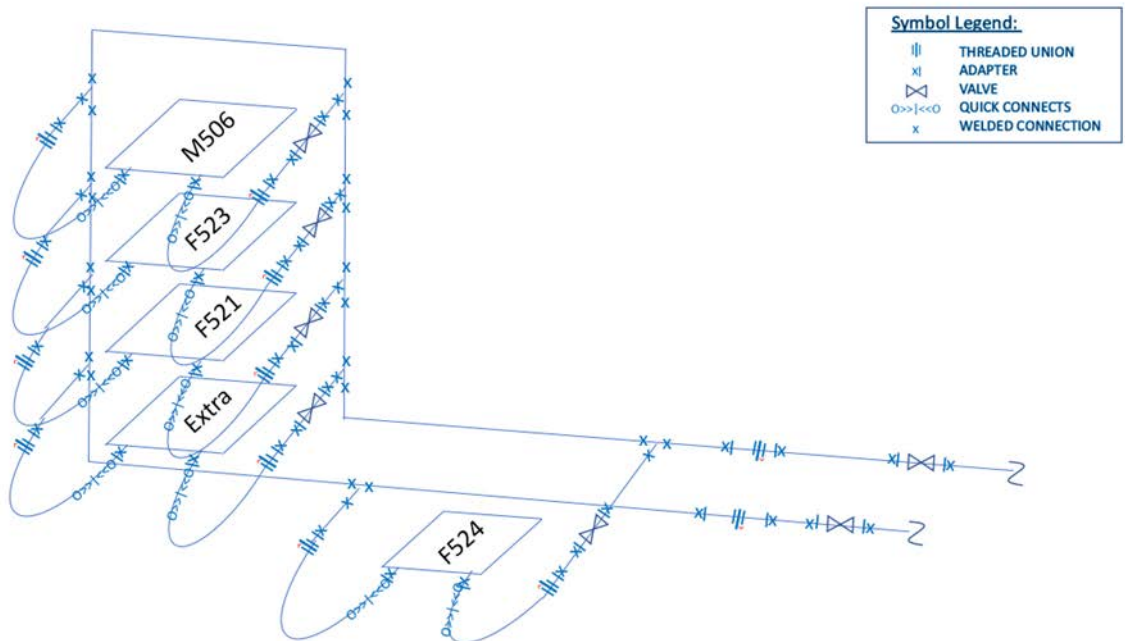

Figure 19. Auxiliary Enclosure Piping Diagram

Title: Antenna Electronics Environmental Control Conceptual Design Description	Author: S. Sturgis	Date: 2024-03-14
NRAO Doc. #: 020.30.60.00.00-DSN		Version: C

WVR:

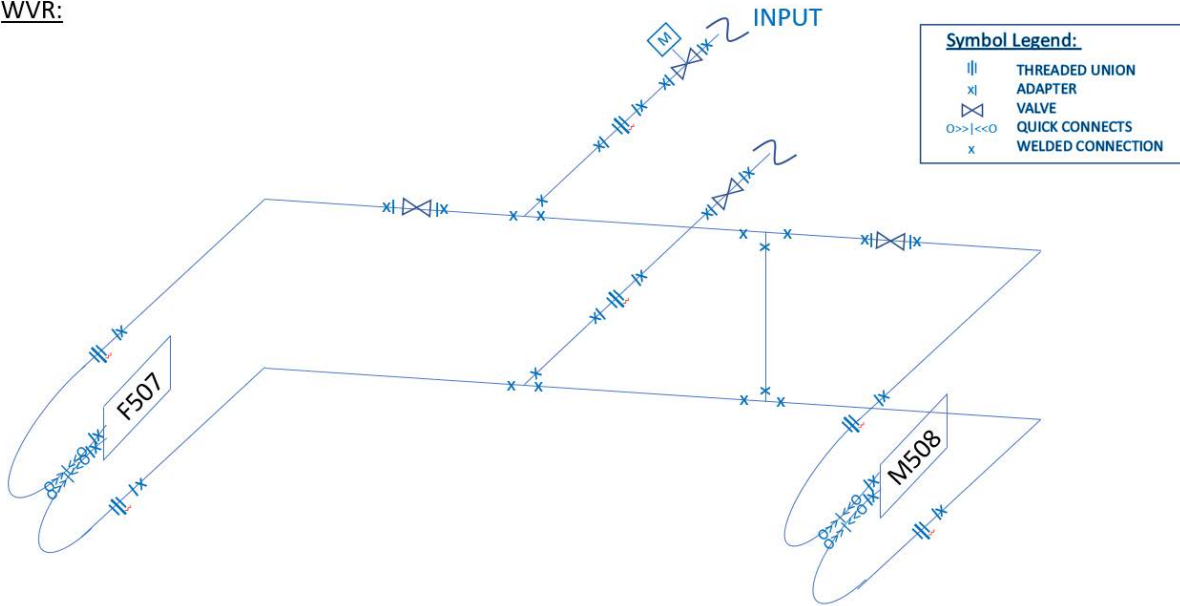

Figure 20. WVR Piping Diagram

CRYO RFI ENCLOSURE :

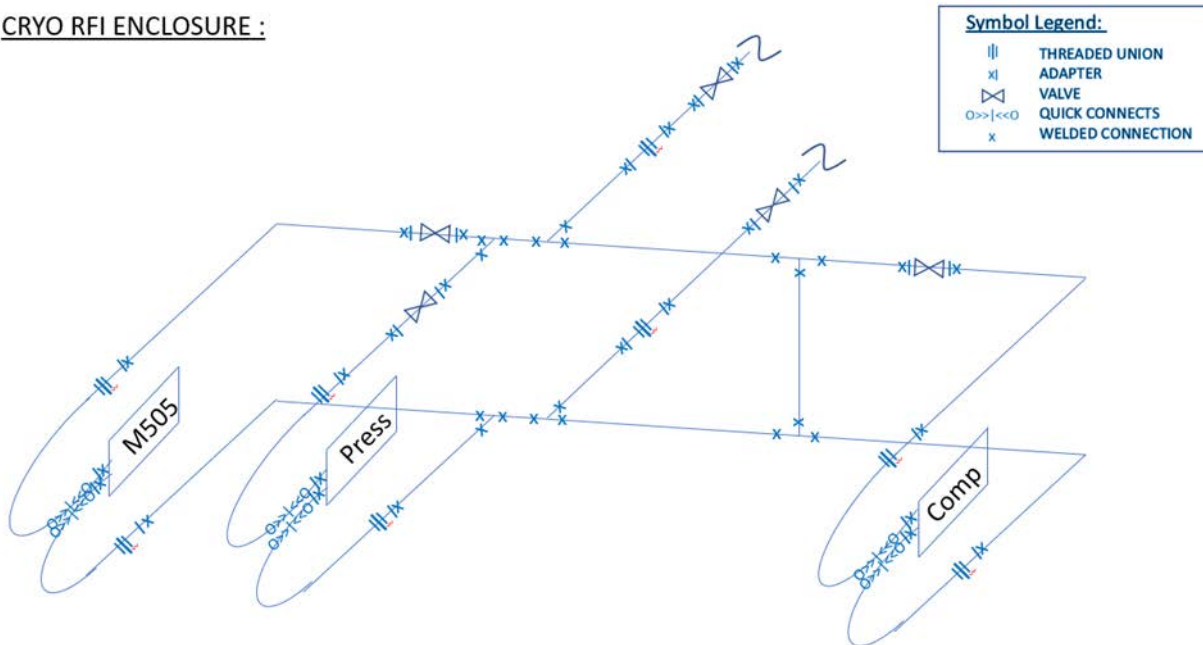

Figure 21. Cryogenics RFI Enclosure Piping Diagram



Title: Antenna Electronics Environmental Control Conceptual Design Description	Author: S. Sturgis	Date: 2024-03-14
NRAO Doc. #: 020.30.60.00.00-DSN		Version: C

Equipment	Max Dissipated heat (W)	Max Req. Glycol @ inlet (liter/min) (assumes 5-10 °C, 60% propylene glycol/water)	Req. Air Flow (M³/s)	Min Glycol Temp (°C)	Allow. ΔT (C°)	Est. ΔP (Pa)
Front End Enclosure	1230	9.5	na	5	5	211890
Auxiliary Enclosure	786	6.25	na	12	15	121600
WVR	156	2.75	na	5	2	60825
Cryogenics RF Enclosure	844	4	na	5	15	91330
Helium Compressor (Sumitomo)	6400	10	na	4	12C min at max flow rate	14.5 psig @ 9 liter/min
Electronics Rack	2792	na	0.24	5	15	500
Rack Air Handler	250	na	na	na	na	na
Total	12458					

Table 6. Glycol flow rate requirements and pressure drop estimates

The glycol flow rates presented in Table 15 are calculated based on the heat loads listed as well as the allowable ΔT of glycol. The Front End and the WVR both require tighter temperature control resulting in a lower ΔT, while the Auxiliary Enclosure, Cryogenics RF Enclosure, and Electronics Rack have more relaxed temperature requirements.

The glycol flow rate requirements calculations took into account not only the heat dissipated by the electronics, but also the heat added from solar radiation and ambient environment. The estimated maximum contributions from solar loading as well as ambient are presented in Table 16.

Location	Solar + Ambient Load
Front End Enclosure	250W
Auxiliary Enclosure	150W
WVR	50W

Table 7. Solar + Ambient Loads

4.4 Reliability, Availability and Maintainability



Title: Antenna Electronics Environmental Control Conceptual Design Description	Author: S. Sturgis	Date: 2024-03-14
NRAO Doc. #: 020.30.60.00.00-DSN		Version: C

The EEC subsystem components have high reliability and low maintenance requirements. However, the EEC subsystem is fully dependent on the Antenna provided glycol loop, and as such the reliability is driven by the glycol system reliability.

The EEC system is primarily made up of COTS parts. Reliability will be a key metric in selecting individual components. Where questions exist regarding the reliability of a component, extensive testing will be done to qualify it to ensure every part of the system is as reliable as practical. Additionally, every effort will be made to reduce the number of valves and other lower reliability components. Although the glycol chiller is not the responsibility of the EEC subsystem, it is expected to be the primary component requiring regular maintenance. Primary maintenance activities will include cleaning the heat exchanger, checking or remotely monitoring refrigerant pressure, and monitoring and refilling the glycol level at regular intervals.

4.5 Technology Readiness Assessment

The EEC subsystem is made up nearly entirely of COTS parts, which are inherently high TRL level. In the few cases where a component is not COTS, it is expected to be a slight modification of a COTS part. However, the integration of all the components together is also part of the TRL level, and that is the least mature part of the design presented here. With that in mind, the TRL level of the entire EEC system is estimated at 5 or 6.



Title: Antenna Electronics Environmental Control Conceptual Design Description	Author: S. Sturgis	Date: 2024-03-14
NRAO Doc. #: 020.30.60.00.00-DSN		Version: C

5 Appendix A: Trade Studies

5.1 Air-cooled vs direct glycol cooled rack equipment

A brief study comparing air cooling or direct glycol cooling of the Electronics Rack equipment was conducted. In the past, NRAO has typically used air cooled racks, but for the ngVLA project all of the equipment on the feed arm will be glycol cooled which led to the consideration of direct glycol cooling in the rack.

A conceptual design and layout of the rack was developed with glycol lines and quick connects for each device that required cooling. Quick connects are used in order to be able to remove and replace individual modules from the rack. The first issue encountered was that some of the commercial rack mounted equipment was not available in any configuration except air cooled. This led to segmenting the rack into upper and lower sections, the upper section with the commercial equipment requiring air flow and the lower section with ARCS modules requiring glycol lines. The glycol lines were run from the underside of the rack, along the rear vertical rails, and then above each bin with modules. A manifold was used to split the main line out to lines going to each module.

A couple of different issues were encountered with the glycol cooled rack design. For one, having the rack split between air cooled and glycol cooled requires an air inlet on only the upper section, implying it would have to be on the front door of the rack (limited space and structural constraints make other inlet locations much more difficult). This would make access to the contents of the rack more difficult. The second problem was cost. The added cost of welded stainless-steel tubing and quick connects was greater than anticipated, and exceeded the cost of air flow baffles and an air handler. Some decrease in the additional cost may be possible with careful design and component selection, but this is not the only concern. An additional concern is that the glycol lines run between bins, taking 1 RU of space between each bin. This takes valuable space that can be used for additional equipment in the air-cooled configuration and could even drive the design to require more than one rack. These issues push the design toward the air-cooled solution. Additionally, around the time the glycol solution was being investigated, the mtex antenna team decided that they would use air cooling for all equipment located in the pedestal RFI room, making air cooling of the rack a significantly more attractive choice.

A couple of different issues with the air-cooling design were also investigated. For one, having air cooled ARCS Modules in the rack but nowhere else on the antenna means that these modules will necessarily be different than the ARCS Modules in other locations around the antenna. This means non-interchangeable designs and parts as well as possibly different manufacturing techniques. However, the number of modules considered is great enough that this may not be a major concern. Another possible issue is that there are a couple of high heat dissipation modules that could be more difficult to properly cool with air and a heatsink, but not enough details of these modules are known yet. If this turns out to be the case, one solution might be to run a glycol line to that individual module as the high heat capacity of glycol may be able to exhaust more heat than the forced air system.

Another quirk with the air-cooled configuration is that the lower section of the rack containing ARCS Modules requires vertical air flow while the upper section of the rack containing commercial equipment requires horizontal, front to rear, air flow. The concept is to have bottom to top air flow for the lower section of the rack, and then direct the air into the space between the front door and the rack mounted equipment, horizontally through the commercial equipment, and then out the top of the rack (Figure 25).

Title: Antenna Electronics Environmental Control Conceptual Design Description	Author: S. Sturgis	Date: 2024-03-14
NRAO Doc. #: 020.30.60.00.00-DSN		Version: C

In conclusion, it was decided to go with the air flow configuration as the baseline as it is simpler, less expensive, and with fewer drawbacks than the direct conduction cooled configuration.

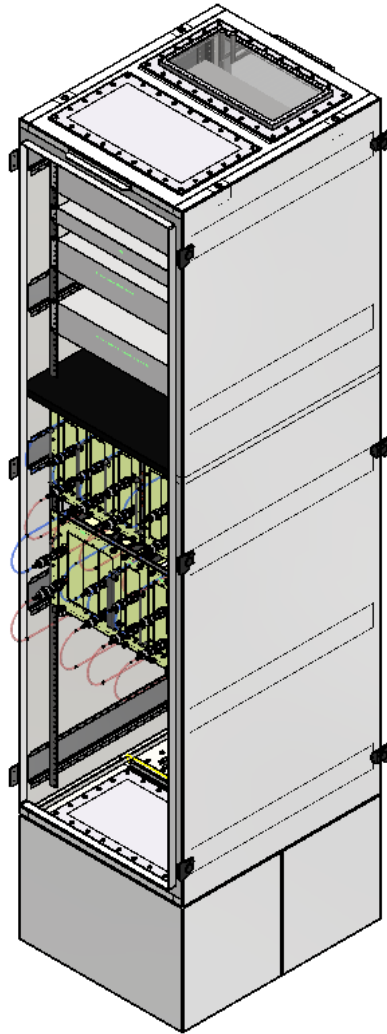

Figure 22. Electronics Rack with direct glycol cooling



Title: Antenna Electronics Environmental Control Conceptual Design Description	Author: S. Sturgis	Date: 2024-03-14
NRAO Doc. #: 020.30.60.00.00-DSN		Version: C

6 Appendix B: Abbreviations and Acronyms

Acronym	Description
AD	Applicable Document
AFD	Antenna Fiber Distribution
ALMA	Atacama Large Millimeter Array
ARCS	Advanced RFI Containment System
ATF	Antenna Time and Frequency
BMR	Bins, Modules, and Racks
COTS	Commercial Off the Shelf
CRY	Cryogenics
DBE	Digital Back End
EEC	Electronics Environmental Control
EMI	Electromagnetic Interference
EVLA	Jansky Very Large Array
FE	Front End
FED	Front End
HIL	Hardware Interface Layer (Monitor and Control)
ICD	Interface Control Document
IRD	Integrated Receivers and Digitizers
LO	Local Oscillator
LRU	Line Replaceable Unit
MCL	Monitor and Control System
ngVLA	Next Generation Very Large Array
RF	Radio Frequency
RFI	Radio Frequency Interference
RTD	LO Reference and Timing - Distribution
TBC	To Be Confirmed
TBD	To Be Determined
TRL	Technology Readiness Level
VFD	Variable Frequency Drive
WVR	Water Vapor Radiometer











020.30.60.00.00-0002-DSN_ELECTRONICS_ENVIRONMENTAL_CONTROL_DESIGN

Final Audit Report

2024-03-18

Created:	2024-03-15
By:	Pieter Kotzé (pkotze@nrao.edu)
Status:	Signed
Transaction ID:	CBJCHBCAABAA07F1BFc51yDPLIVfVE-4hizy16ZoessT

"020.30.60.00.00-0002-DSN_ELECTRONICS_ENVIRONMENTAL_CONTROL_DESIGN" History

-  Document created by Pieter Kotzé (pkotze@nrao.edu)
2024-03-15 - 9:44:24 PM GMT
-  Document emailed to ssturgis@nrao.edu for signature
2024-03-15 - 9:45:27 PM GMT
-  Email viewed by ssturgis@nrao.edu
2024-03-15 - 9:51:22 PM GMT
-  Signer ssturgis@nrao.edu entered name at signing as Silver Sturgis
2024-03-15 - 9:53:12 PM GMT
-  Document e-signed by Silver Sturgis (ssturgis@nrao.edu)
Signature Date: 2024-03-15 - 9:53:14 PM GMT - Time Source: server
-  Document emailed to plopez@nrao.edu for signature
2024-03-15 - 9:53:16 PM GMT
-  Email viewed by plopez@nrao.edu
2024-03-15 - 10:23:09 PM GMT
-  Signer plopez@nrao.edu entered name at signing as Phillip Lopez
2024-03-18 - 2:30:08 PM GMT
-  Document e-signed by Phillip Lopez (plopez@nrao.edu)
Signature Date: 2024-03-18 - 2:30:10 PM GMT - Time Source: server
-  Document emailed to Pieter Kotzé (pkotze@nrao.edu) for signature
2024-03-18 - 2:30:12 PM GMT



 Email viewed by Pieter Kotzé (pkotze@nrao.edu)

2024-03-18 - 2:36:07 PM GMT

 Document e-signed by Pieter Kotzé (pkotze@nrao.edu)

Signature Date: 2024-03-18 - 2:36:16 PM GMT - Time Source: server

 Document emailed to Rob Selina (rselina@nrao.edu) for signature

2024-03-18 - 2:36:18 PM GMT

 Email viewed by Rob Selina (rselina@nrao.edu)

2024-03-18 - 2:46:07 PM GMT

 Document e-signed by Rob Selina (rselina@nrao.edu)

Signature Date: 2024-03-18 - 2:48:42 PM GMT - Time Source: server

 Document emailed to Willem Esterhuyse (westerhu@nrao.edu) for signature

2024-03-18 - 2:48:44 PM GMT

 Email viewed by Willem Esterhuyse (westerhu@nrao.edu)

2024-03-18 - 3:25:41 PM GMT

 Document e-signed by Willem Esterhuyse (westerhu@nrao.edu)

Signature Date: 2024-03-18 - 3:25:55 PM GMT - Time Source: server

 Agreement completed.

2024-03-18 - 3:25:55 PM GMT

