



Title: Cryogenic Subsystem Design Description	Author: D. Urbain	Date: 2023-09-14
NRAO Doc. #: 020.30.10.00.00-0007-DSN		Version: C



Cryogenic Subsystem Design Description

020.30.10.00.00-0007-DSN

Status: **RELEASED**

PREPARED BY	ORGANIZATION	DATE
D. Urbain; P. Lopez	NRAO	2022-09-14

APPROVALS	ORGANIZATION	SIGNATURES
P. Lopez	NRAO	<u><i>Phillip Lopez</i></u> Phillip Lopez (Sep 14, 2023 14:25 MDT)
P. Kotzé	NRAO	<u><i>P.P.A. Kotzé</i></u> P.P.A.Kotzé (Sep 14, 2023 15:35 MDT)
R. Selina	NRAO	<u><i>RJS</i></u> RJS (Sep 15, 2023 09:08 MDT)
W. Hojnowski	NRAO	<u><i>William Hojnowski</i></u> William Hojnowski (Sep 19, 2023 10:06 MDT)

RELEASED BY	ORGANIZATION	SIGNATURES
W. Hojnowski	NRAO	<u><i>William Hojnowski</i></u> William Hojnowski (Sep 19, 2023 10:06 MDT)



Title: Cryogenic Subsystem Design Description	Author: D. Urbain	Date: 2023-09-14
NRAO Doc. #: 020.30.10.00.00-0007-DSN		Version: C

Change Record

Version	Date	Author	Affected Section(s)	Reason
A	2021-11-08	D. Urbain	All	The first approved version was released for the System CDR.
B	2022-08-17	D. Urbain	Sections 3.3 and 4.2.1.6	Updated according to the System CDR RIDS. BASELINE VERSION.
C	2023-09-14	D. Urbain	All Sections 4.2.1.1.2, 4.2.1.4, 4.4.3, 4.4.4, 4.4.5	Edited the complete document with Grammarly. Updated figures 2, 5 and 15. Change the text to comply with ECN 0001 and ECN 0005. Removed the back-pressure regulator option for the pressure regulator because it was abandoned.



Title: Cryogenic Subsystem Design Description	Author: D. Urbain	Date: 2023-09-14
NRAO Doc. #: 020.30.10.00.00-0007-DSN		Version: C

Table of Contents

1	Introduction	6
1.1	<i>Purpose and Scope.....</i>	6
2	Related Documents and Drawings	6
2.1	<i>Applicable Documents</i>	6
2.2	<i>Reference Documents.....</i>	6
3	Subsystem Overview	8
3.1	<i>High-Level Description</i>	8
3.2	<i>Design Driving Requirements.....</i>	8
3.2.1	Cooling Capacity.....	9
3.2.2	Temperature Stability.....	9
3.2.3	Compressor Power Consumption	9
3.2.4	Flow Capacity	9
3.2.5	Mean Time Between Maintenance (MTBM)	10
3.2.6	Serviceable on Site	10
3.2.7	Altitude Range.....	10
3.2.8	Temperature Range.....	10
3.2.9	Design Life.....	10
3.2.10	Vacuum Pump Ultimate Pressure	10
3.2.11	Vacuum Pump Pumping Speed.....	11
3.3	Key Risks.....	11
3.3.1	Technical Risks	11
3.3.2	RFI Risk.....	11
3.3.3	Maintenance Risks	11
3.3.4	Operation Risks	12
3.4	Design Assumptions.....	12
4	Cryogenic Subsystem Design	13



Title: Cryogenic Subsystem Design Description	Author: D. Urbain	Date: 2023-09-14
NRAO Doc. #: 020.30.10.00.00-0007-DSN		Version: C

4.1	Product Structure.....	13
4.1.1	Product Context	13
4.1.2	Product Breakdown Structure	14
4.1.3	Block Diagram	15
4.2	Product Design.....	15
4.2.1	Hardware Description.....	15
4.2.2	Monitoring and Control	44
4.2.3	Functional Diagram	46
4.2.4	Electronic Design.....	49
4.2.5	Mechanical Design	51
4.3	Performance Budgets	54
4.4	Environmental Protection	55
4.4.1	Temperature Range.....	55
4.4.2	Altitude	57
4.4.3	Precipitation.....	57
4.4.4	Ice Accumulation.....	57
4.4.5	Wind Protection	58
4.5	RFI, EMC, and Lightning Protection.....	58
4.5.1	RFI/EMC Protection	58
4.5.2	Lightning Protection	60
4.6	Power Supply and Distribution	60
4.7	Reliability, Availability, and Maintainability.....	60
4.7.1	Reliability	60
4.7.2	Availability.....	61
4.7.3	Maintainability	61
4.8	Manufacturability.....	61
4.9	Safety Analysis.....	61
4.9.1	Personnel Safety.....	61



Title: Cryogenic Subsystem Design Description	Author: D. Urbain	Date: 2023-09-14
NRAO Doc. #: 020.30.10.00.00-0007-DSN		Version: C

4.9.2 Hardware Safety..... 62

4.10 Technology Readiness Assessment 62

4.10.1 Helium Compressor 63

4.10.2 Cryocooler..... 63

4.10.3 Helium Pressure Regulation Module..... 64

4.10.4 Dual Sleeve..... 64

4.11 Down-Selects 64

5 Appendix A: Trade Studies 65

6 Appendix B: Abbreviations and Acronyms..... 65



Title: Cryogenic Subsystem Design Description	Author: D. Urbain	Date: 2023-09-14
NRAO Doc. #: 020.30.10.00.00-0007-DSN		Version: C

1 Introduction

1.1 Purpose and Scope

The purpose of this document is to define the design of the ngVLA cryogenic subsystem for the conceptual design phase of its development.

The design is driven by the requirements stated in [AD01], and the purpose of the design description is to define a design that can meet all the requirements stated in [AD01].

The design description is a holistic definition of the design, including performance, functional, mechanical, environmental, safety, reliability, availability, and maintainability characteristics. The design should also show compliance to external interfaces in cases where the interfaces have a direct impact on the design.

2 Related Documents and Drawings

2.1 Applicable Documents

The following documents may not be directly referenced herein, but provide necessary context or supporting material.

Ref. No.	Document Title	Rev/Doc. No.
AD01	Cryogenic Subsystem Requirements	020.30.10.00.00-0001-REQ
AD02	ngVLA Electronics Memo No. 12: Thermoacoustic Stirling Cryocooler and Variable Speed Gifford McMahon Cryocooler Trade Study No. 2	22 October 2021
AD03	Cryogenic Concept Selection	020.30.10.00.00-0007-REP
AD04	18m Cryogenics Volume and Mass Requirements	020.30.03.10.00-0001-DWG
AD05	ngVLA System Requirements	020.10.15.10.00-0003-REQ

Table 1: Applicable documents.

2.2 Reference Documents

The following documents are referenced within this text:

Ref. No.	Document Title	Rev/Doc. No.
RD01	Application of Energy Efficient Scroll Compressor for Small Cars	International Refrigeration and Air Conditioning Conference 2004



Title: Cryogenic Subsystem Design Description	Author: D. Urbain	Date: 2023-09-14
NRAO Doc. #: 020.30.10.00.00-0007-DSN		Version: C

RD02	Conductance Calculation – Molecular Flow, Long Tube of Circular Cross Section. Sanyi Zheng, April 1993	
RD03	The Basis of Vacuum. G. Vandoni, CERN 2012	
RD04	ngVLA Front End Receivers Thermal Study Dewar-B Update, Antonella Simone, Remi Rayet, Callisto S.A. 14/02/2020	
RD05	System Electromagnetic Compatibility and Radio Frequency Interference Mitigation Requirements	020.10.15.10.00-002-REQ

Table 2: Reference documents.

Title: Cryogenic Subsystem Design Description	Author: D. Urbain	Date: 2023-09-14
NRAO Doc. #: 020.30.10.00.00-0007-DSN		Version: C

3 Subsystem Overview

3.1 High-Level Description

The purpose of the cryogenic subsystem is to cool the sensitive Front End electronics to a very low temperature (20K) to minimize self-generated noise and improve the telescope's overall sensitivity. The subsystem comprises a compressor, a couple of cryocoolers (one per Front End cryostat), and some interconnecting lines to circulate the pressurized helium gas. A pressure regulation module is connected to the helium circuit to compensate for the diurnal pressure variations typically produced by ambient temperature changes and the small helium leaks through O-rings and seals within the system. A vacuum pump removes the air trapped inside the Front End cryostats ahead of the cool down to eliminate any heat transfer by convection and avoid ice formation on the cold surfaces.

3.2 Design Driving Requirements

A subset of the key requirements that drive the design is shown in Table 3 below.

Parameter	Summary of Requirement	Reference
Cooling Capacity	The cryocooler shall have enough cooling capacity to reach 80K with a thermal load of 20W on the first stage and 20K with a thermal load of 4W on the second stage.	CRY0800
Temperature Stability	The magnitude of the temperature variations on the second stage shall not exceed 0.12K over a period of 200 seconds.	CRY0801
Compressor Power Consumption	During normal operation, the helium compressor shall not consume more than 5.54 kW.	CRY1001
Compressor Flow Capacity	The compressor shall have enough capacity to run two cryocoolers with the cooling power specified in CRY0800.	CFRY0803
Mean Time Between Maintenance (MTBM)	The cryogenic subsystem shall be designed for an expected MTBM for the entire subsystem of 8,333 hours.	CRY0100
Serviceable Onsite	The cryocooler shall be serviceable/swappable onsite by one technician in less than 2 hours.	CRY0109
Altitude Range	The cryogenic subsystem shall operate normally at altitudes ranging from sea level up to 2500m.	CRY0020
Temperature Range	The cryogenic subsystem shall perform normally in the $-25^{\circ}\text{C} \leq T \leq 45^{\circ}\text{C}$ temperature range.	CRY0002

Title: Cryogenic Subsystem Design Description	Author: D. Urbain	Date: 2023-09-14
NRAO Doc. #: 020.30.10.00.00-0007-DSN		Version: C

Design Life	The cryogenic subsystem shall be designed for an expected operational life of no less than 30 years.	CRY0600
Vacuum Pump Ultimate Pressure	The vacuum pump shall have an ultimate pressure \leq 0.2Pa (1.5millitorr).	CRY0812
Vacuum Pump Pumping Speed	The vacuum pump shall have a nominal pumping speed 18m ³ /h.	CRY0813

Table 3: Key cryogenic subsystem requirements.

3.2.1 Cooling Capacity

The cooling capacity requirement is set by the Front End cryostats, the goal being to achieve the 20K temperature for the low noise amplifiers. Because the Front End cryostats are under development, the thermal loads were estimated using early concepts and a thermal load calculation tool called ThermXL [RD04]. The work was subcontracted to the French company Callisto SA, which provided detailed reports that allowed us to establish the cooling capacity requirement for the cryocoolers.

3.2.2 Temperature Stability

The temperature stability requirement derives directly from the gain stability requirement of the low noise amplifiers. As the physical temperature of an amplifier changes, its gain amplitude varies, and this change in output signal amplitude could be misinterpreted as a fluctuation of the source signal. The temperature stability requirement is set to meet the overall system stability and extend the interval between calibrations to maximize the time the telescope spends on-source.

3.2.3 Compressor Power Consumption

Within the cryogenic subsystem, the compressor has the most significant power consumption. Because the system runs continuously, the cryogenics energy cost represents a substantial portion of the total energy cost for the array. The goal for the ngVLA operation budget is to be at most three times the current VLA budget. The three compressors operating on each of the 27 VLA antennas have a combined power consumption of 18 kW; because they run at a fixed speed, their total energy consumption is 18 kWh in one hour. For ngVLA, a single compressor will be required per antenna, and a simple scaling calculation gives an allowed power consumption per compressor of $(18 \times 27 \times 3) / 263 = 5.54$ kW. However, the compressor will operate at variable speeds. Therefore, the energy consumed could change, but the average value shall be at most 5.54 kWh per hour.

3.2.4 Flow Capacity

The current design uses a single compressor per antenna to run two cryocoolers, one per Front End cryostat. Each cryocooler requires a minimum helium flow to operate correctly and meet the cooling requirement, so the compressor shall deliver enough flow for two. The flow produced by the compressor varies with its operating speed; the requirement assumes that the compressor runs at 60 Hz and that both cryocoolers are also running at their nominal speed (72 rpm).



Title: Cryogenic Subsystem Design Description	Author: D. Urbain	Date: 2023-09-14
NRAO Doc. #: 020.30.10.00.00-0007-DSN		Version: C

3.2.5 Mean Time Between Maintenance (MTBM)

In addition to the energy cost, the cryogenic subsystem requires periodic maintenance. Most service operations are predictable and can be scheduled following a preventive maintenance concept. This approach minimizes the impact on science and simplifies the logistics, but it is also more expensive because components are replaced before their end-of-life cycle.

A second approach is planned corrective maintenance, where the system is continuously monitored to find problems and predict failures before they occur. This more cost-effective solution will have to be implemented over time as system knowledge is improved and failure prediction tools are developed. The cryogenic subsystem MTBM is directly derived from the antenna MTBM and is ultimately set by the array availability for science operation requirements.

3.2.6 Serviceable on Site

Over the years, NRAO has accumulated much knowledge on the GM cryocoolers and knows that while they are reliable, they require periodic maintenance because the cold head moving parts wear out. The cold head is the component that needs to be serviced most often. While replacing a cold head is a delicate operation, it should be possible to do on the antenna by a single technician to account for the limited accessibility.

3.2.7 Altitude Range

With a span of several thousand miles, the ngVLA project will have antennas in very diverse locations, from the low elevation of the United States Virgin Islands to the high elevations of Hawaii's volcano and New Mexico plains. The highest antenna site elevation shall not exceed 2500m in the current geographic configuration. The cryogenic equipment shall be the same at every site and operate normally regardless of location and altitude.

3.2.8 Temperature Range

The cryogenic equipment shall operate normally over a broad range of ambient temperatures, ranging from the cold winters of New Mexico and the northeastern United States to the warm summers in Mexico and California. At this project stage, it is assumed that the cryogenic subsystem will be exposed to the entire temperature range of -25°C to 45°C , at least for the 6m antenna. The 18m antenna concept proposed by Mtex has relocated the compressor inside the turn-head away from the elements. Most environmental requirements like wind, rain, and ice are no longer a concern, but how controlled the antenna pedestal temperature will be is yet to be confirmed.

3.2.9 Design Life

The array shall operate for a minimum of 20 years after completion of construction. It is estimated that ten years will be needed to complete the array's construction. Therefore, the cryogenic subsystem shall have an expected life of no less than 30 years.

3.2.10 Vacuum Pump Ultimate Pressure

A Front End cryostat must be evacuated before the cryocooler can be started. Otherwise, the thermal loading by convection will overwhelm the cryocooler, and it will fail to cool. Empirically, a minimum



Title: Cryogenic Subsystem Design Description	Author: D. Urbain	Date: 2023-09-14
NRAO Doc. #: 020.30.10.00.00-0007-DSN		Version: C

vacuum pressure is established to guarantee that the thermal loading by convection will not impair the cooling process (best practice recommends at least 10^{-3} Torr before cooling, per J.G. Weisend). The vacuum pump must have an ultimate pressure below the required vacuum pressure. A vacuum pressure of 10–5 Torr or better is recommended to neglect the convection heat-leak in the thermal load calculation.

Because we are using a cryocooler, some of the inner surfaces of the cryostat will cool by conduction below 77K. At that temperature, most of the gas will condense and freeze; this process is called cryo-pumping and is very effective. The recommended vacuum pressure required to ignore the thermal loading by convection can be achieved easily through cryo-pumping as long as the system is leak-tight and the outgassing is limited.

3.2.11 Vacuum Pump Pumping Speed

The pumping speed is essential because it determines how long it takes to reach the vacuum pressure required to start the cool-down. The evacuation time depends on the overall volume to pump, the conductance of the vacuum hoses and other vacuum plumbing, the cleanliness of the inner surfaces, and the amount of outgassing from the cryostat construction materials.

3.3 Key Risks

3.3.1 Technical Risks

The GM solution for the cryogenic subsystem is a low-technical risk option as this cryocooler type has been in operation for several decades at the VLA and many other radio observatories worldwide. Most components are Commercial-Off-the-Shelf (COTS), and the few custom assemblies, like the pressure regulation module, are built primarily from commercial parts. Some electronics will be custom, but the design will follow the project guidelines and use components from the approved list wherever possible.

3.3.2 RFI Risk

The inverter that drives the compressor at a variable frequency and the VFD electronics for the cold head are susceptible to generating RFI. Proper shielding will be required to maintain the emission levels below the threshold value. Previous experiences with inverter-driven compressors have shown us that the attenuation level needed should be achievable with traditional methods.

3.3.3 Maintenance Risks

The GM cryocoolers require periodic maintenance, and the fact that the maintenance concepts and the service procedures need to be better defined represents a risk in terms of operating costs. For example: if the service of the GM cold head on the antenna is not practical and the complete Front End enclosure needs to be replaced instead, the procedure will require more people and more equipment, increasing the maintenance cost significantly. Having to transport the Front End enclosures more frequently could also negatively impact the reliability of some of the components inside. For example, the mechanical vibrations produced during transportation and handling could stress the bounding wires inside the low noise amplifiers and induce premature failures.

The GM cryogenic system is a distributed system: the compressor and the helium pressure regulation module are inside the turn-head or on a platform behind the dish, while the cold heads are at the end of



Title: Cryogenic Subsystem Design Description	Author: D. Urbain	Date: 2023-09-14
NRAO Doc. #: 020.30.10.00.00-0007-DSN		Version: C

the antenna feed arm, inside the Front End enclosure. A series of rigid and flexible lines connect them, and each interconnection is a possible source of leakage. A leaky system is a maintenance nightmare because finding the leak could be very time-consuming and require heavy equipment to reach certain parts of the system.

3.3.4 Operation Risks

While the cooling capacity of the GM cryocooler is not a concern because of the large selection available on the market, the thermal stability requirement could be challenging to achieve.

3.4 Design Assumptions

For this design description document, the following assumptions were made.

- The Front End heat loads will not exceed the estimated 15W on the first stage and 4W on the second stage.
- The helium compressor cooling requirement will be met by a glycol loop on the 18m antenna; for the 6m, the compressor will likely be air-cooled and placed outside the antenna structure.
- The 18m antenna has the helium compressor, the pressure regulation module, and the compressor VFD RFI enclosure inside the turn-head. The operating temperatures of each component will be controlled by individual cold plates connected to the glycol circuit.
- The 6m antenna will most likely have the helium compressor, the pressure regulation module, and the compressor VFD RFI enclosure outside and exposed to the weather.

Title: Cryogenic Subsystem Design Description	Author: D. Urbain	Date: 2023-09-14
NRAO Doc. #: 020.30.10.00.00-0007-DSN		Version: C

4 Cryogenic Subsystem Design

4.1 Product Structure

4.1.1 Product Context

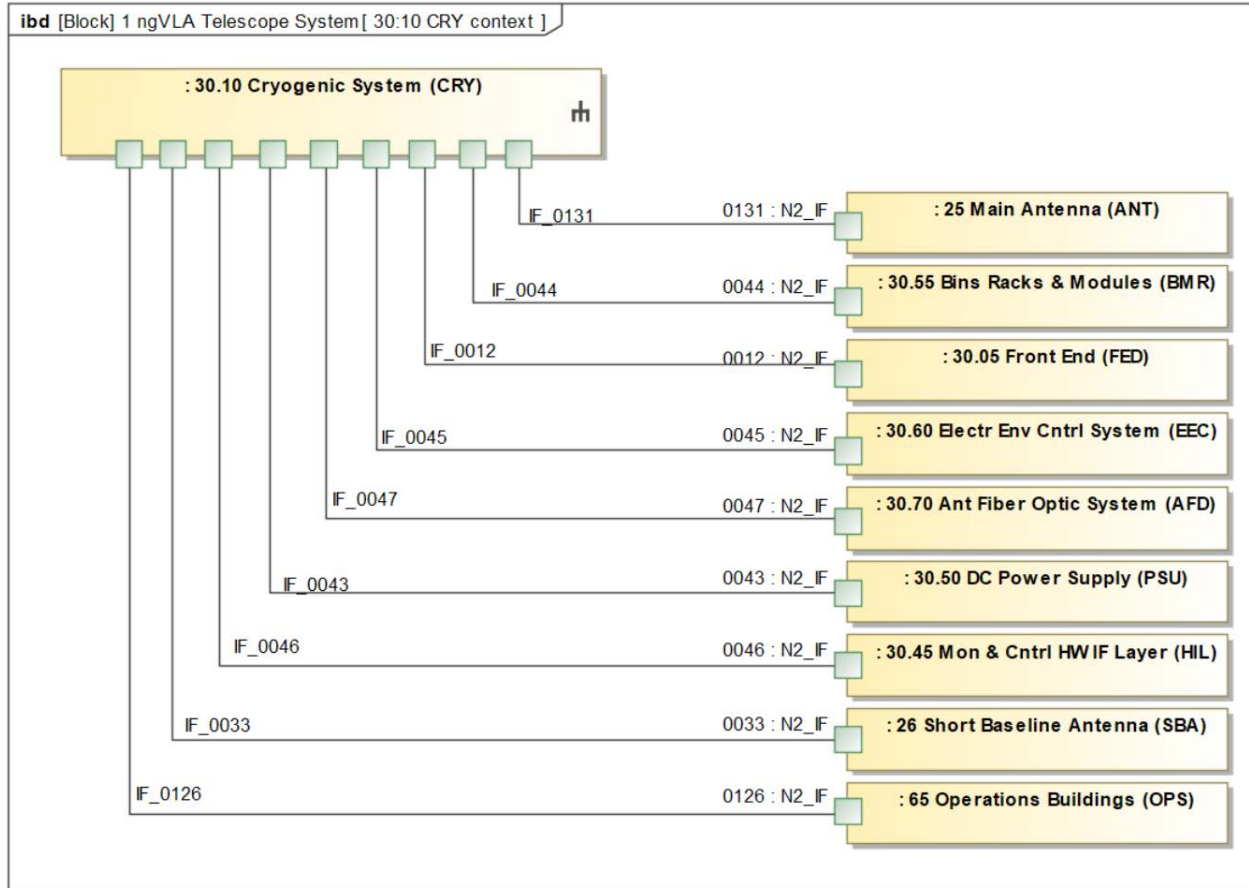

Figure 1: Block diagram of the cryogenic subsystem in context of other ngVLA subsystems.



Title: Cryogenic Subsystem Design Description	Author: D. Urbain	Date: 2023-09-14
NRAO Doc. #: 020.30.10.00.00-0007-DSN		Version: C

4.1.2 Product Breakdown Structure

Component	Configuration Item Number	
Cryogenic Subsystem	30.10.10.00	
Cryostat A Cold Head	30.10.10.01	LRU
Cryostat B Cold Head	30.10.10.02	LRU
<i>Cold head sleeve Dewar A (TBC)</i>	<i>30.10.10.03</i>	SRU
<i>Cold head sleeve Dewar B (TBC)</i>	<i>30.10.10.04</i>	SRU
Cold head VFD Controller	30.10.11.00	LRU
Cold head VFD Driver	30.10.12.00	LRU
Cryostat VFD Cabling	30.10.13.00	RR
Cryostat A&B sensors	30.10.14.00	LRU
Helium System	30.10.20.00	
Helium Compressor	30.10.21.00	LRU
Helium Pressure Regulation Assembly	30.10.22.00	LRU
Helium Pressure regulation cabling	30.10.23.00	RR
Helium Supply Tank	30.10.24.00	LRU
Helium Buffer Tank	30.10.25.00	LRU
Helium Distribution	30.10.26.00	LRU
Compressor VFD Drive Electronics	30.10.27.00	LRU
Compressor VFD Cabling	30.10.28.00	RR
Vacuum system	30.10.30.00	
Vacuum Pump	30.10.31.00	LRU
Vacuum Pump Driver	30.10.32.00	LRU
Vacuum pump drive cabling	30.10.33.00	RR
Vacuum distribution	30.10.34.00	LRU
Front End Vacuum sensors & control	30.10.35.00	LRU

Table 4: List of configuration item numbers for the cryogenic subsystem.

Title: Cryogenic Subsystem Design Description	Author: D. Urbain	Date: 2023-09-14
NRAO Doc. #: 020.30.10.00.00-0007-DSN		Version: C

4.1.3 Block Diagram

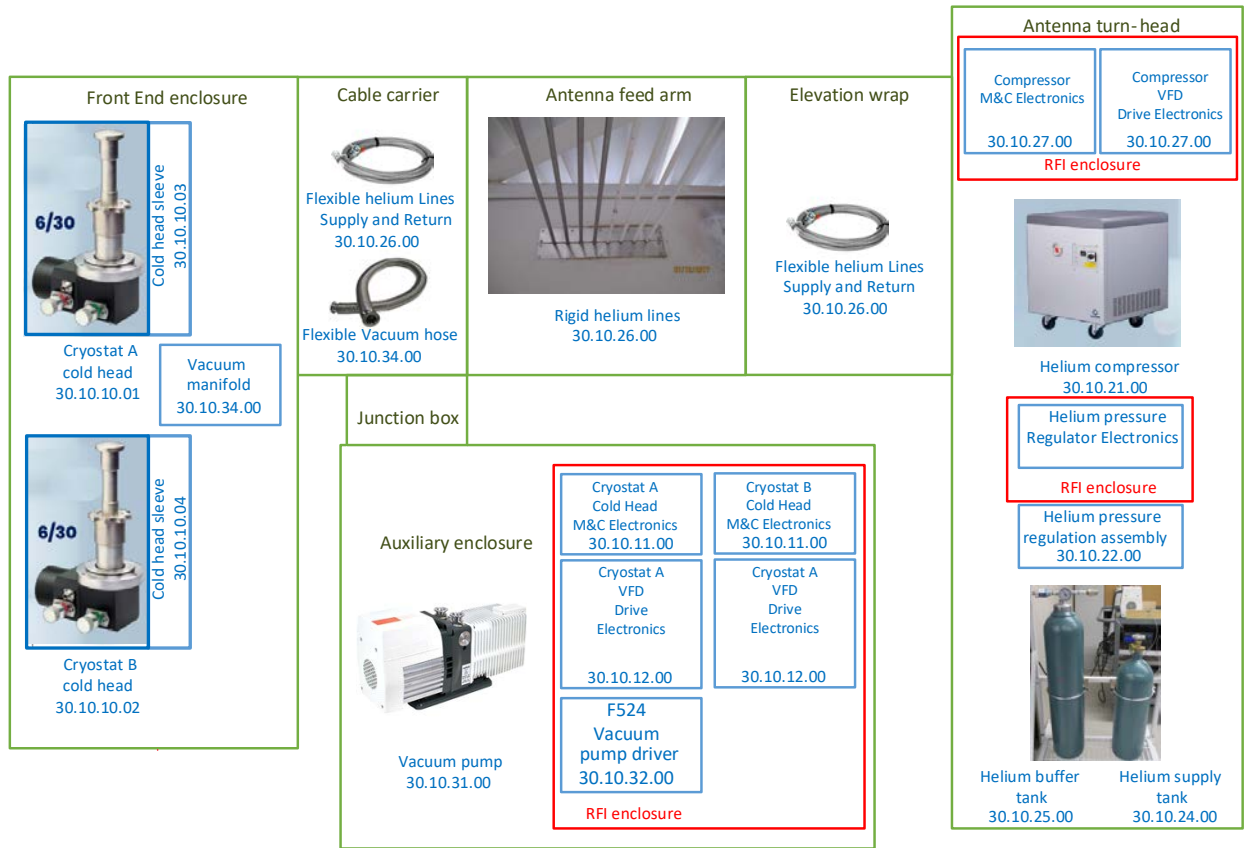

Figure 2: Block diagram of the cryogenic subsystem.

4.2 Product Design

4.2.1 Hardware Description

4.2.1.1 Compressor

The compressor is the heart of the helium circuit. Inside the compressor, the helium gas is compressed to approximately 300 psi and then circulated through a series of flexible and rigid lines to the cryocooler. Modern helium compressors in the 3–6 kW range use scroll capsules commonly found in refrigeration and air conditioning equipment because they are quieter, run smoother, are reliable, and are more cost-effective than conventional reciprocating type compressors.

4.2.1.1.1 Scroll Compressor Capsule

The compressor is comprised of a fixed scroll and an orbiting scroll, as shown in Figure 3 (next page). The gas enters the fixed scroll at the suction chamber, and as the orbital scroll moves, it pushes the gas towards the center, reducing its volume progressively until the gas reaches the discharge chamber at the center.

Title: Cryogenic Subsystem Design Description	Author: D. Urbain	Date: 2023-09-14
NRAO Doc. #: 020.30.10.00.00-0007-DSN		Version: C

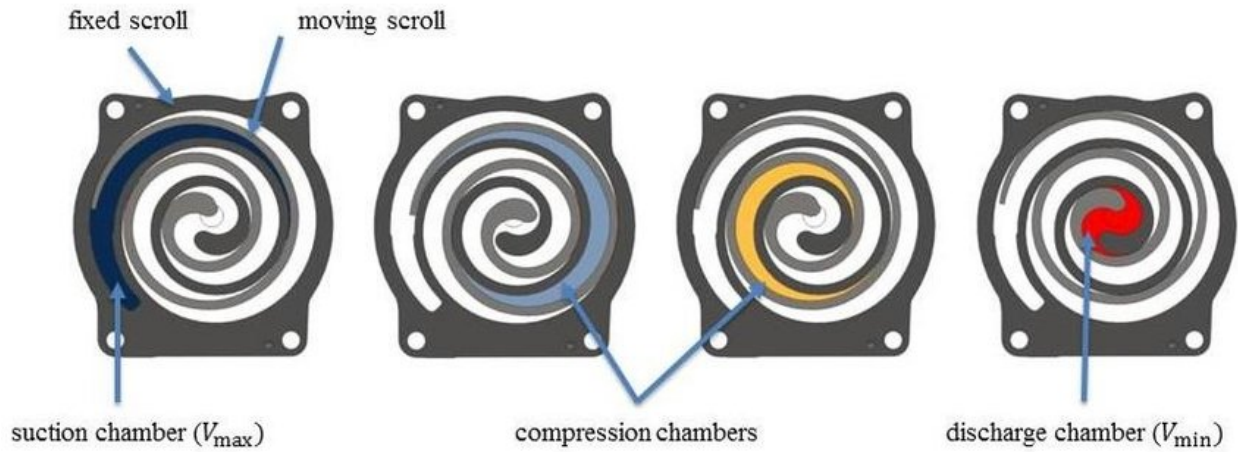

Figure 3: Compression principle of the scroll compressor.

It has been demonstrated [RD01] that scroll compressors have a higher efficiency than reciprocating compressors, possibly reducing power consumption by up to 25%. The small number of moving parts compared to a piston-type compressor (see Figure 4) makes them less prone to mechanical failures and reduces the required maintenance. However, unlike the reciprocating compressors, the scroll capsules are welded assemblies that are not repairable and must be replaced in case of failure.

The orbital motion of the scroll reduces the rubbing velocity by 30% to 50% compared with piston rings, enhancing the durability of the compressor. The continuous motion of the scroll makes the compressor suitable for variable speed operation, unlike the reciprocating type that works well at specific duty cycles.

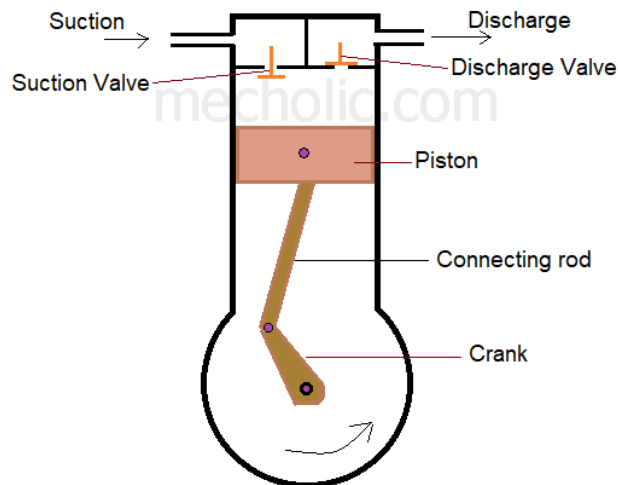

Figure 4: Reciprocating compressor.

Scroll compressors exist in oil-free versions because the scrolls don't need to touch to compress the gas as long as the gap between them is very small. However, the compression of helium gas generates a lot of heat, and to improve the cooling, the helium gas is mixed with oil. The oil lubricates the moving parts for increased longevity and enhances the seal between the two scrolls by filling the tiny gap between

Title: Cryogenic Subsystem Design Description	Author: D. Urbain	Date: 2023-09-14
NRAO Doc. #: 020.30.10.00.00-0007-DSN		Version: C

them for better compression. The oil also carries away the small debris (mechanical wear) that will be removed by filters placed on the return lines to the capsule and provides a cooling effect that helps with heat removal.

4.2.1.1.2 Oil Management

The oil must be separated from the helium gas before reaching the cryocooler. Otherwise, it will freeze and seize the moving displacer, causing a catastrophic failure. The oil-gas separation is done in a three-step process; Figure 5 shows the Oxford Cryosystems compressor flow diagram, similar to most compressors on the market.

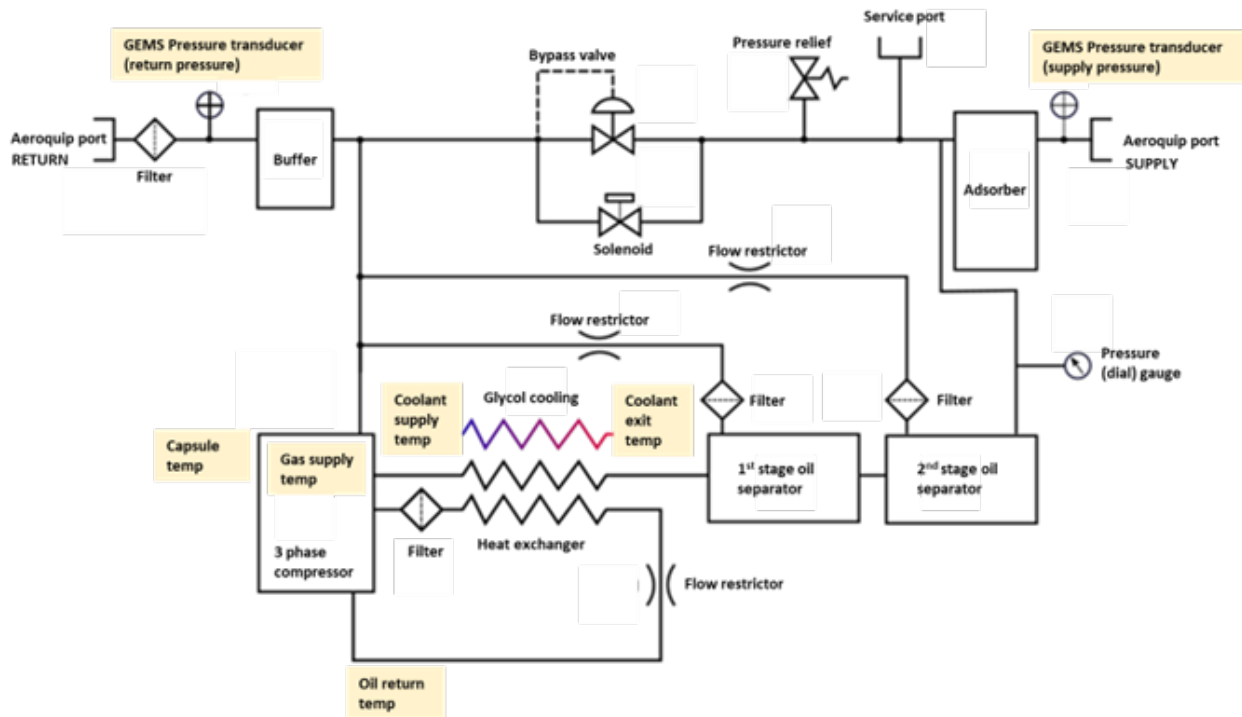

Figure 5: Oxford Cryosystems compressor flow diagram.

- **Bulk oil separator:** The oil-gas mixture exits the scroll capsule at high pressure and temperatures and enters heat exchange to cool and start condensing the oil. Inside the bulk oil separator, the oil is separated from the helium gas by impingement or flow through screens or matrix. The oil collects at the bottom of the reservoir and is sent by the pressure differential to the heat exchanger to be cooled before it is filtered and sent back to the low-pressure side of the scroll compressor. This first step in the oil-gas separation should remove more than 99% of the oil.
- **Oil mist separator:** When the helium gas exits the bulk oil separator, it flows through the oil mist separator. A series of tightly stacked wool felt pads or glass fiber blankets collect the small oil particles that accumulate at the bottom of the separator. The collected oil is sent back to the compressor capsule by differential pressure. On the way, the oil goes through a filter that eliminates any debris in suspension.



Title: Cryogenic Subsystem Design Description	Author: D. Urbain	Date: 2023-09-14
NRAO Doc. #: 020.30.10.00.00-0007-DSN		Version: C

- **Adsorber:** This is the final stage of the oil-gas separation, and unlike in the other two stages, the oil captured is not recirculated back to the compressor capsule. The adsorber is a container filled with screens and activated charcoal that traps and keeps the remaining oil molecules. Over time, the ability of the charcoal to capture and retain the oil diminishes, requiring the adsorber to be replaced at regular intervals (30,000 hours).

4.2.1.1.3 Compressor Selection

The critical parameters for the compressor selection are:

- **Flow capacity:** Once the size and number of cryocoolers have been determined, the required flow can be estimated, and the minimum size of the compressor established. For ngVLA, the compressor must have enough flow capacity to drive two cryocoolers at their nominal speed.
- **Power consumption:** The maximum power consumption requirement will help eliminate some compressors from the list established by the flow capacity. The maximum power consumption was calculated to meet the operation cost requirement of three times the current VLA number; 5.54 kW is the maximum power dissipation allowed for the compressor at 60 Hz. It is important to note that the value listed above applies to both compressor configurations, liquid-cooled and air-cooled, but does not account for the power dissipated by the glycol chiller.
- **Power availability:** The type of AC power available on the antenna will reduce the selection further. The preferred voltage is 480VAC 3-phase, but 208VAC 3-phase could also be considered.
- **Environmental conditions:** These will impose some restrictions on the type of enclosure and materials used to build the compressor. For example, they might also set some design accommodations to meet the temperature range.
- **Type of cooling:** A compressor can be air-cooled or liquid-cooled; often, the same size compressor is available in both configurations. The compressor location on the 18m antenna favors the liquid-cooled configuration, while the reduced size of the 6m will most likely impose an air-cooled design.
- **Variable-speed operation:** The variable speed operation adjusts the flow to match cryocooler requirements, eliminating the gas going through the internal bypass and reducing power consumption. The feature is highly recommended but unnecessary if the compressor flow perfectly matches the cryocooler requirement. Since the cryocooler will operate at variable speeds, the compressor will include a VFD to fully control the cooling power and the power consumption.

For the mtex 18m antenna, the proposed location of the compressor inside the turn-head had the engineering team reconsider the air-cooled configuration of the reference design in favor of the liquid-cooled option. The team concluded that the smaller size of the compressor, the simpler installation, the elimination of the cumbersome ductwork, and the potential reduction in maintenance were sufficient to justify the increase in total power consumption due to the added load onto the glycol chiller. A back-of-the-envelope calculation estimates that the compressor will add a maximum of 1.5 Tons to the chiller load. Medium-size chillers commonly achieve a 0.9 kW/Ton cooling efficiency, giving a maximum power consumption difference between the two options of 1,150 mW after subtracting 200 mW to run the cooling fan on the air-cooled compressor.

The current selection of liquid-cooled compressors for the 18m antenna is listed in Table 5.

Title: Cryogenic Subsystem Design Description	Author: D. Urbain	Date: 2023-09-14
NRAO Doc. #: 020.30.10.00.00-0007-DSN		Version: C

Manufacturer	Sumitomo	Oxford Cryosystems
Model	F-40H	Prototype Variable speed
Power consumption	4.6-5.6 kW	3kW @ 30Hz, 6kW @ 75Hz
Power type	480VAC 3-phase 60Hz	480VAC 3-phase 60Hz
Ambient temperature	4 to 40°C	5 to 40°C
Cooling type	Liquid	Liquid
Cooling water	4–9L/min at 5 to 25°C	4–8 L/min at 5 to 26°C
Dimension (HxWxD)	532 x 442 x 493 mm	894.5 x 542.5 x 559.6 mm
Weight	96 kg	120 kg

Table 5: List of liquid-cooled compressors selected for the 18m antenna.

Note: The standard Oxford Cryosystems liquid-cooled compressor, the K450, uses 208 VAC single phase, but the capsule can be replaced with the Hitachi S305DHV-40D2UC designed for high voltage and VFD operation.

Because of the reduced antenna size, the turn-head of the 6m antenna will likely not be large enough to enclose the helium compressor. The possible selection of outdoor air-cooled compressors for the 6m antennas is listed in Table 6. Both options will require engineering development to meet the temperature range and the power consumption requirements.

Manufacturer	Sumitomo	Oxford Cryosystems
Model	Custom FA-40 with FA-70 enclosure	K450-AC3 modified for extended temperature range and larger Hitachi capsule
Power consumption	4.6–5.6 kW	3kW @ 30Hz, 6kW @ 75Hz
Power type	480VAC 3-phase 60Hz	480VAC 3-phase 60Hz
Ambient temperature	–30 to 45°C	–25 to 45°C
Cooling type	Air	Air
Dimension (HxWxD)	1016 x 391 x 948 mm	1640 x 660 x 620 mm
Weight	142 kg outdoor unit only	250 kg includes M&C electronics and adsorber

Table 6: List of outdoor air-cooled compressors selected for the 6m antennas.

Title: Cryogenic Subsystem Design Description	Author: D. Urbain	Date: 2023-09-14
NRAO Doc. #: 020.30.10.00.00-0007-DSN		Version: C

4.2.1.2 Cold Head

The cold head, also called cryocooler, is the component of the cryogenic circuit that produces the cooling effect. A typical cryocooler is shown in Figure 6.

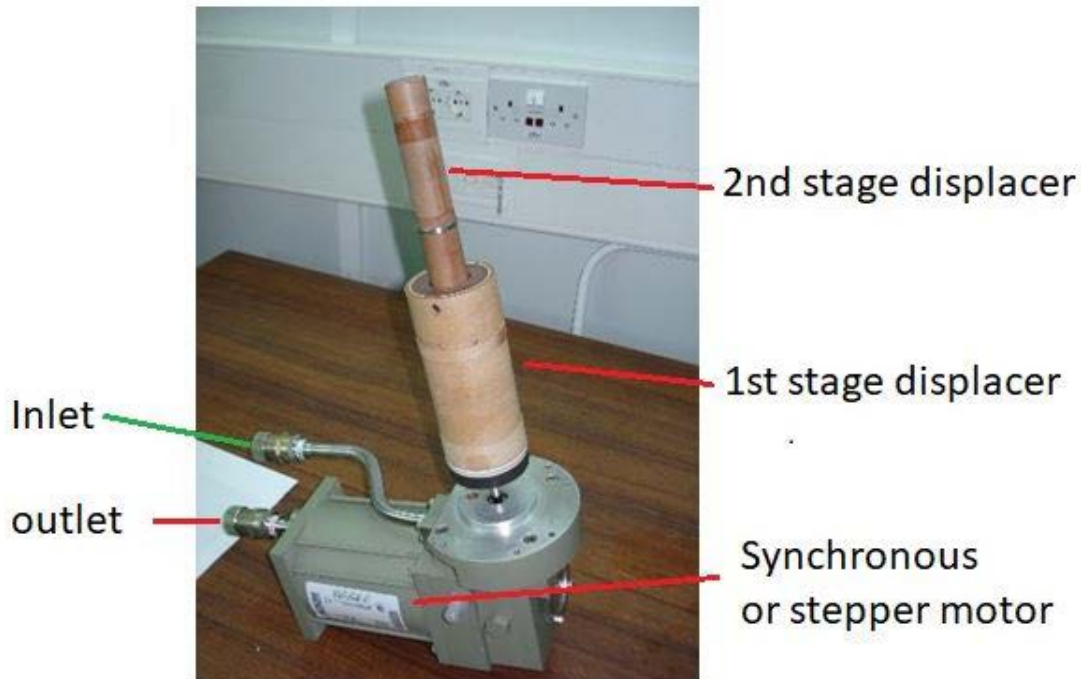

Figure 6: A 2-stage Trillium 350CS cryocooler.

The high-pressure helium gas enters the cold head by the inlet valve and flows through the first and second-stage regenerators as the displacer moves upwards (Figure 7, below). The regenerator materials absorb some of the carried heat, cooling the gas. The cooled high-pressure gas accumulates at the first- and second-stage expansion chambers, the inlet valves close, and the outlet valves open. At that moment, the high-pressure gas is connected to the low-pressure side of the circuit. The gas expands and cools, absorbing heat from the first- and second-stage heat loads. The displacer moves downwards, forcing the cold gas through the regenerators; this time, the gas absorbs some of the regenerator heat before exiting the cold head by the outlet valve in the direction of the compressor.

Title: Cryogenic Subsystem Design Description	Author: D. Urbain	Date: 2023-09-14
NRAO Doc. #: 020.30.10.00.00-0007-DSN		Version: C

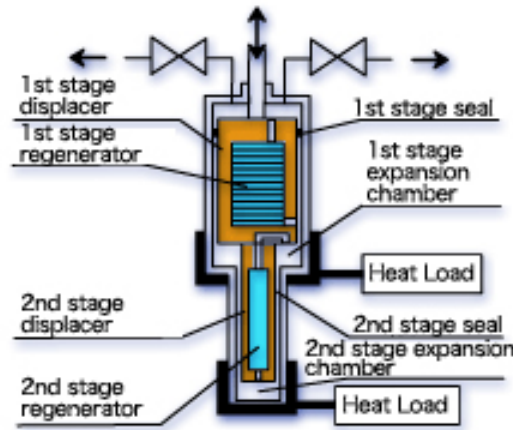

Figure 7. Cross section of a 2-stage GM cryocooler.

4.2.1.2.1 Cryocooler Selection

The key parameters for the selection of a cryocooler are listed below:

- **Achievable temperature:** The lowest temperature that must be achieved by the cryocooler will determine the number of stages and the materials selected for the regenerators. For ngVLA, the low-noise amplifiers need to be cooled at 20K or below for optimum gain and noise performances. A 2-stage cryocooler is required, and stainless steel or copper meshes can be used for the first stage regenerator. Lead spheres will be packed inside the second-stage regenerator.
- **Cooling capacities:** The heat loads applied to the first and second stages will determine the cooling capacities. For ngVLA, the heat loads were estimated from early cryostat design, using a software package called ThermXL. The work was subcontracted to the French company Callisto SA; see [RD04]. It was determined that 15W at 80K and 4W at 20K cooling capacities were required.
- **Variable speed operation:** The variable speed operation allows the cooling capacities to be adjusted to maintain a desired cold temperature and reduce the wear and tear on the cryocooler.

The current selection of cryocoolers for ngVLA is listed in Table 7.

Manufacturer	Trillium	Sumitomo	Oxford Cyosystems	Oxford Cryosystems
Model	350CS	CH-204SFF	6/30	4/20 ⁽²⁾
Weight	10kg	7.8kg	6.1kg	TBD
Dimensions H x W x D	470 x 152 x 300.5	475.9 x 133.4 x 180 mm	344 x 155 x 207 mm	TBD
Motor type	AC Synchronous	AC Synchronous	Hybrid stepper	Hybrid stepper
Cooling capacity 1 st stage ⁽¹⁾	20W @ 77K	16.2W @ 80K	30W @ 77K	20 @ 77K

Title: Cryogenic Subsystem Design Description	Author: D. Urbain	Date: 2023-09-14
NRAO Doc. #: 020.30.10.00.00-0007-DSN		Version: C

Cooling capacity 2 nd stage (1)	5W @ 20K	9.0W @ 20K	6W @ 20K	4W @ 20K
Variable speed capable	Yes	TBD	Yes	Yes
Operating speed @ 60Hz	36-84 rpm	72 rpm	40-90 rpm	40-90rpm

Table 7: List of cryocooler contenders for ngVLA.

Note (1): the cooling capacities are specified for the nominal speed of 72rpm and for the variable speed units at 60Hz. The cold heads were selected to have at least a 20% margin in the second-stage cooling capacity because this is the most critical temperature for Front End performance. The first-stage temperature has less effect because it is mainly used to cool the radiation shield, the wiring, and the RF connections.

Note (2): The Oxford Cryosystems 4/20 cold head is a proposed development for ngVLA; the idea is to build a cold head that will match our requirements more closely, allowing their K450 compressor to drive two units.

The motor of the Trillium 350Cs drives the displacer and actuates the valve. In the case of the Oxford Cryosystems and Sumitomo cold heads, the motor operates only the valve. The difference in gas pressure between the supply and the return moves the displacer up and down inside the chamber. The motor rotates a valve that successively connects the cold head inner volume to the helium circuit’s high-pressure and low-pressure sides. When the high pressure enters the sleeve, it goes through the displacer, and the internal matrix materials cool the gas and accumulates at the tip pushing the displacer up. When the low-pressure side is connected, the gas expands, gets colder, and flows through the displacer, cooling it as it exits the cold head. Once the pressure at the tip drops at or below the low pressure, the displacer moves back down, and the cycle repeats.

4.2.1.2.2 Dual-Sleeve Concept

The French company Callisto SA currently offers the dual-sleeve concept (Figure 8) to replace the cold heads as a completely sealed unit, pressurized with helium.

Title: Cryogenic Subsystem Design Description	Author: D. Urbain	Date: 2023-09-14
NRAO Doc. #: 020.30.10.00.00-0007-DSN		Version: C

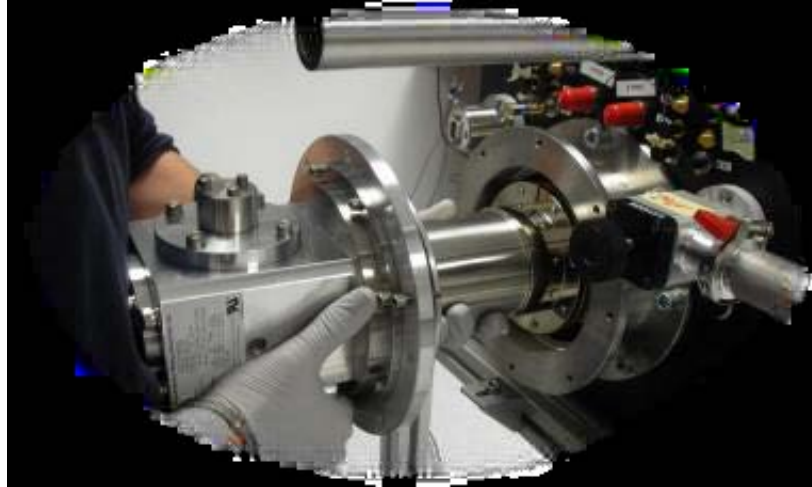

Figure 8: Dual sleeve for the Sumitomo CH-204SFF cold head developed by Callisto SA.

This solution will eliminate the risk of seal damage during the displacer insertion and contamination if the flushing procedure fails when the cold head is swapped on the antenna. If the potential benefits for maintenance are clear, the impacts on the system are significant and must be fully understood before the project develops the concept.

Benefits	Drawbacks
Eliminate the risk of seal damage	Add weight to the Front End enclosure: 10–15kg per cold head
Eliminate the risk on contamination	Increase the thermal load 3.6W from 300K to 50K 0.1W from 50K to 10K
Performances guaranteed after installation	Additional thermal interface 0.6K/W at 20K
	Added cost could be significant (TBC)

Table 8: Benefits and drawbacks of the dual-sleeve concept.

The concept adds a second sleeve to the cold head that weighs 10–15 kg, doubling approximately the assembly’s weight. In principle, running the cold head at a higher operating speed could compensate for the thermal load increase. However, that would also demand an increase of the compressor speed, which will raise the power consumption and reduce the interval between maintenance proportionally. If we add the capital cost to the operating cost increase, the benefits might not be strong enough to justify the investment.

Because the dual-sleeve concept has to be designed for a specific cold head, it would make sense to start the development after selecting the production cold head. However, Callisto has an open design ready for the Sumitomo CH-204SFF cold head, so converting the design to a closed configuration could be done quickly and for a reasonable cost. Funding this study ahead of the Preliminary Design Review (PDR) would

Title: Cryogenic Subsystem Design Description	Author: D. Urbain	Date: 2023-09-14
NRAO Doc. #: 020.30.10.00.00-0007-DSN		Version: C

save time because the evaluation of the dual-sleeve concept could be completed and a decision made ahead of the PDR. This is important because the Front End Cryostat design can only be completed once the cryocooler is selected and the sleeve design is done if used.

4.2.1.2.3 Temperature Stabilization

The second stage of the cryocooler is used to cool the low noise amplifiers, and the gain of a device varies with its physical temperature. To meet the overall system stability requirement, the temperature stability of the second stage of the cryocooler shall not exceed 0.12K per 200 seconds. The GM type cryocoolers see their temperatures oscillate in sync with the movement of their displacer, and even if the amplitude of the oscillations could be reduced by the thermal mass connected to each stage, it might still exceed the requirement.

The orientation of the cryocooler as the antenna moves in elevation could also change the temperature because the cooling capacity might be orientation-dependent. The gas pressure, ambient temperature, sun exposure, and anything else that could change the cooling capacity or thermal loading will impact the second-stage temperature. Luckily, most of the induced temperature changes will be slow and could be compensated by adjusting the speed of the cryocooler.

For the fast temperature changes that could compromise the gain stability of the LNAs, two options are considered to reduce the temperature variations of the cryocooler.

- **Passive temperature stabilization:** This solution is inspired by the ALMA 3-stage cryocooler, where a small reservoir of liquid helium is used to improve the stability of the third stage at 4K and below. The heat capacity of the liquid helium is used as a thermal buffer to dampen the temperature oscillations at the cryocooler and thermal bus interface. This solution is simple and highly effective. For ngVLA, because the temperature of interest is 20K, the helium will have to be replaced by hydrogen. The danger of explosion presented by hydrogen gas is a concern and should be carefully examined before this solution is developed.

Figure 9 (below) shows the concept of the hydrogen circuit. At room temperature, the small buffer tank is filled with hydrogen gas at a pressure of 12 atmospheres. During the cool down, when the temperature of the second stage cryocooler drops below 32.5K, the gas will start condensing inside the cold reservoir.

As the temperature continues to drop, more and more gas liquefies inside the small reservoir, and the pressure in the buffer tank drops. At 20K, most of the hydrogen gas is in liquid form inside the cold reservoir and acts as a thermal buffer to reduce the temperature oscillation of the second stage. It is essential to always maintain a positive pressure in the buffer tank to avoid any risk of contamination of the hydrogen gas.

Title: Cryogenic Subsystem Design Description	Author: D. Urbain	Date: 2023-09-14
NRAO Doc. #: 020.30.10.00.00-0007-DSN		Version: C

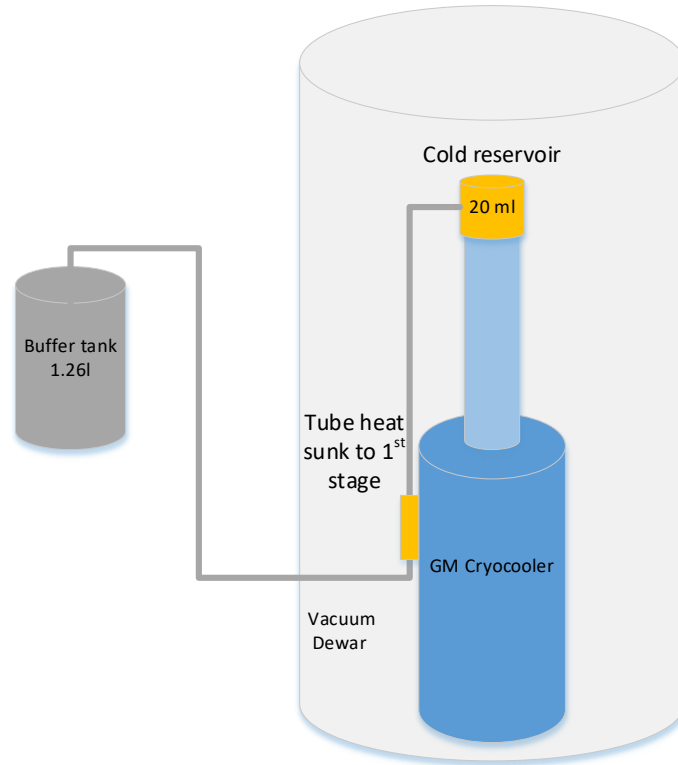

Figure 9: Schematic of the hydrogen temperature stabilization circuit.

- **Active temperature stabilization:** This is a more traditional approach where heat resistors and a PID controller are used to regulate the temperature of the cryocooler actively. The initial idea is to control the temperature at the cryocooler and thermal bus interface. This should guarantee the temperature stability of the individual cartridges.

While both options will be thoroughly investigated after the PDR, once the production cold head is selected and the Front End cryostat prototypes are built, it is in our best interest to measure and characterize the temperature oscillations throughout the design phase. The origin(s) of the temperature variations should be confirmed, and how the geometry and construction of the thermal links and the thermal mass connected impact the amplitude should be well understood.

4.2.1.2.4 Acoustic Troubleshooting Tool

On the VLA, various groups visit the antennas frequently; if a cold head makes an unusual noise, the cryogenic group is alerted immediately. Someone from the group assesses the problem and decides what needs to be done. For ngVLA, the service personnel rarely visit the antennas, but detecting an issue like a contaminated helium circuit or a failing cold head early could prevent severe damage to the equipment and save a lot of effort and money. Acoustic sensors will be mounted on the cold heads to replace the human ear and remotely detect unusual noises that could indicate a problem that needs to be addressed as soon as possible. This new failure detection or prediction type will be essential to reduce maintenance costs.

Title: Cryogenic Subsystem Design Description	Author: D. Urbain	Date: 2023-09-14
NRAO Doc. #: 020.30.10.00.00-0007-DSN		Version: C

4.2.1.3 Helium Lines

These lines transport the helium gas from the compressor to the cold head and back to form a closed loop. Because the compressor is located inside the antenna turn-head or behind the dish, and the cold heads are at the end of the feed arm, some line sections can be rigid, while other sections must be flexible to accommodate the antenna movements.

4.2.1.3.1 Rigid Lines

When the lines are not required to move with the antenna, they are usually built out of seamless stainless-steel tubing (Figure 10). The tubing diameter can vary between 1/2 inch and 3/4 inch; it depends on the length of the lines and the pressure drop that can be tolerated. The tubing sections are pre-formed to follow the antenna contours and are connected with Swagelok fittings or welded in place. The lines are anchored to the antenna structure and clearly identified with the labels “supply” and “return.”



Figure 10: Example of rigid helium lines on a VLA antenna.

4.2.1.3.2 Flexible Lines

Because the compressor is located above the azimuth bearing inside the turn-head structure or on a platform behind the primary reflector, a section of the helium line needs to run through the elevation wrap to reach the feed arm. Another flexible section is necessary between the auxiliary enclosure and the Front End enclosure to run through the cable carrier. An example of the flex line construction is shown in Figure 11. The thickness and pitch of the corrugated inner core will determine line rigidity. An outside armor casing can be added to restrict the bending radius, and help bend the line more evenly to prevent high-stress areas. The lines will flex continuously as the antenna moves in elevation, so it is essential to respect the recommended dynamic bending radius to avoid mechanical stress that could lead to premature failure and leakage. Because pressure affects the rigidity of the line, it must be accounted for during the bending radius calculation. If the line is exposed to water in cold temperatures, ice could form, impair flexibility, and compromise reliability. A protective waterproof sleeve could avoid water intrusion between the corrugated inner core and the braid.

Title: Cryogenic Subsystem Design Description	Author: D. Urbain	Date: 2023-09-14
NRAO Doc. #: 020.30.10.00.00-0007-DSN		Version: C

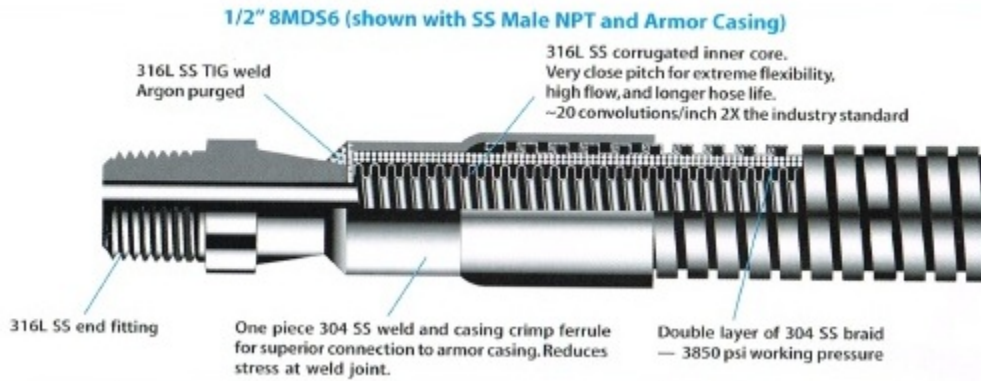

Figure 11: Example of flex line construction for the elevation wrap and the Front End enclosure cable carrier.

The elevation wrap is where it is essential to avoid possible abrasion, stress, or fatigue of the line because it is the most flexed section of the line and the most common place for failure on the VLA.

4.2.1.3.3 Helium Line Couplings

The standard fittings for the cryogenic equipment are the self-sealing couplings from the Aeroquip 5400 series. They are pretty sturdy and can maintain the circuit pressure when decoupled, thanks to the spring-loaded valves on the male and female coupling, as seen in Figure 12.

Title: Cryogenic Subsystem Design Description	Author: D. Urbain	Date: 2023-09-14
NRAO Doc. #: 020.30.10.00.00-0007-DSN		Version: C

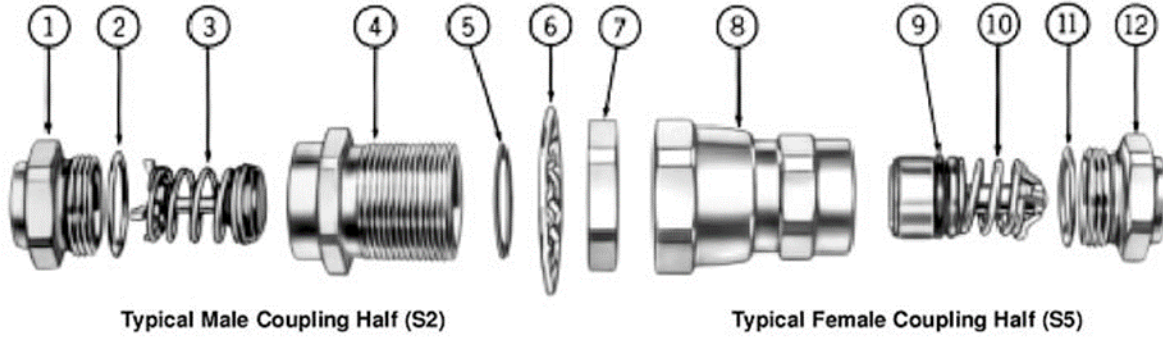

Component Part Numbers

Item No.	Dash Size › O.D. Tube Size ›	-4	-8	-12	-16	Line Ref.
		1/4"–3/8"	1/4"–5/8"	5/8"–7/8"	7/8"–1 3/8"	
Typical Male Half						1
1	Tubing Adapter	202208–*–4	202208–*–8	202208–*–12	202208–*–16	2
2	O-Ring	22546–12	22546–17	22546–23	22546–28	3
3	Poppet Valve Assembly	5400–S20–4	5400–S20–8	5400–S20–12	5400–S20–16	4
4	Body	5400–17–4	5400–17–8	5400–17–12	5400–17–16	5
5	Gasket Seal	22008–4	22008–8	22008–12	22008–16	6
6	Lock Washer	5400–54–4S	5400–54–8S	5400–54–12S	5400–54–16S	7
7	Jam Nut	5400–53–4S	5400–53–8S	5400–53–12S	5400–53–16S	8
Typical Female Half						9
8	Union Nut and Body Assembly	5400–S16–4	5400–S16–8	5400–S16–12	5400–S16–16	10
9	O-Ring	22546–10	22546–112	22546–116	22546–214	11
10	Valve and Sleeve Assembly	5400–S19–4	5400–S19–8	5400–S19–12	5400–S19–16	12
11	O-Ring	22546–12	22546–17	22546–23	22546–28	13
12	Tubing Adapter	202208–*–4	202208–*–8	202208–*–12	202208–*–16	14

*Specify O.D. Tubing size of adapter required in 16th of an inch. Example: –4 coupling with 3/8" O.D. tubing is 3/8" or –6. Part number is then 202208–6–4.

Figure 12: Aeroquip 5400 series coupling exploded view.

Title: Cryogenic Subsystem Design Description	Author: D. Urbain	Date: 2023-09-14
NRAO Doc. #: 020.30.10.00.00-0007-DSN		Version: C

4.2.1.4 Pressure Regulation Module

The pressure regulation module compensates for diurnal and seasonal pressure variations and extends the interval between helium charges. Figure 13 shows an example of the diurnal pressure variation for the compressor cooling the Q-band receiver on Antenna 6 in June 2019.



Figure 13: Example of diurnal pressure variation on Antenna 6 Q-band (VLA June 2019).

The change in pressure translates to a temperature variation of the cryocooler and the cold electronics. Figure 14 shows the temperature variations induced by the diurnal pressure variations. This might not be critical to meet the temperature stability requirement of 0.12K over 200 seconds because the pressure changes are slow.

Title: Cryogenic Subsystem Design Description	Author: D. Urbain	Date: 2023-09-14
NRAO Doc. #: 020.30.10.00.00-0007-DSN		Version: C

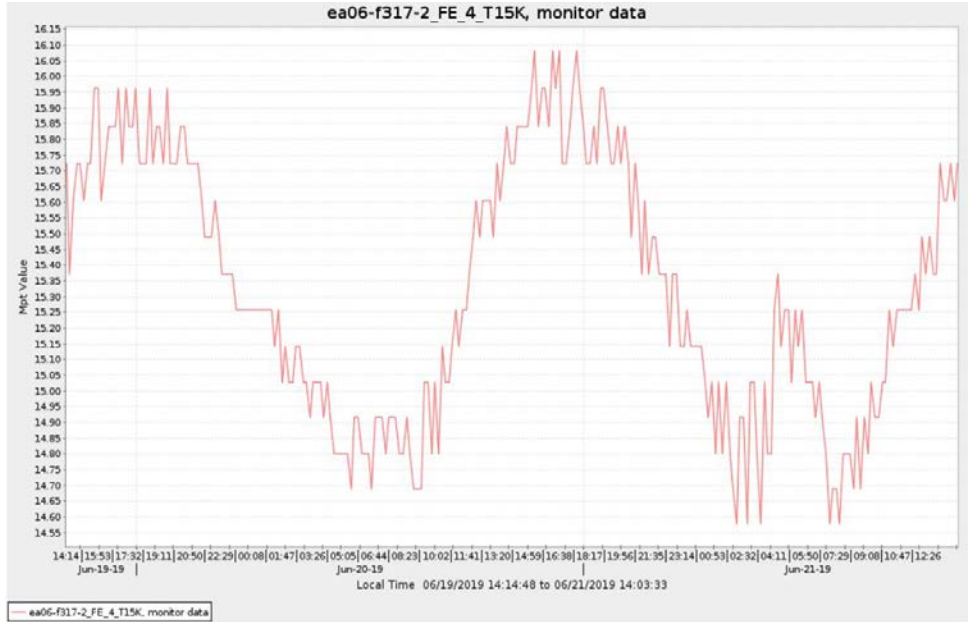

Figure 14: Temperature variations induced by the diurnal pressure variation on the Antenna 6 Q-band.

The most crucial role of the pressure regulation module (Figure 15) is to compensate for small helium leaks through O-rings, couplings, and possible air-line cracks that require the helium circuit to be recharged periodically. Having a 60 cubic-foot helium cylinder connected to the pressure regulation module should allow the circuit to be service-free for a long time, and the goal is to synchronize the bottle refill with the cold head swaps or overall antenna maintenance and repairs.

Title: Cryogenic Subsystem Design Description	Author: D. Urbain	Date: 2023-09-14
NRAO Doc. #: 020.30.10.00.00-0007-DSN		Version: C

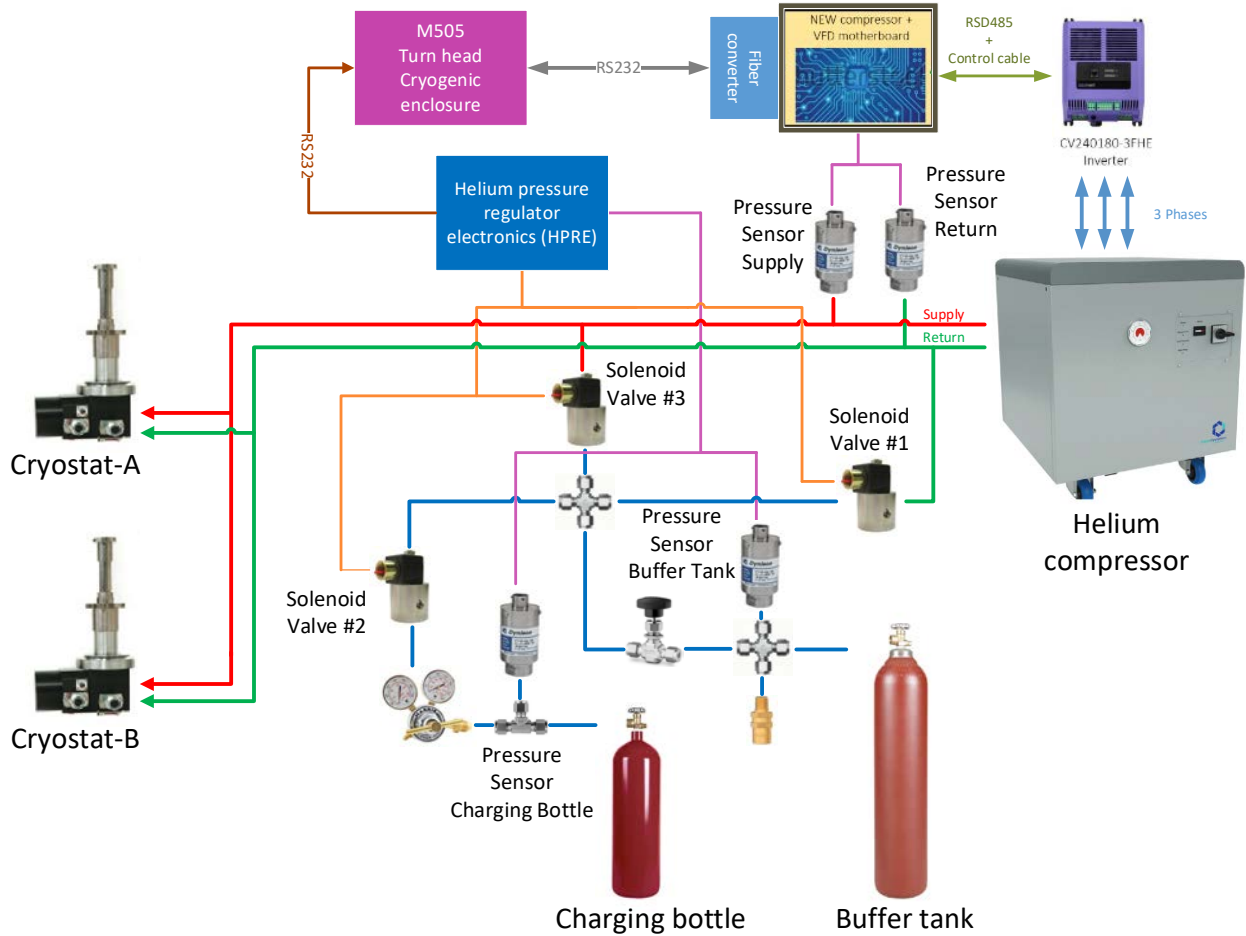

Figure 15: Pressure regulation module schematic.

4.2.1.4.1 Solenoid Valves

These normally closed solenoids (Figure 16) are rated for 10,000 PSIG and are actuated by 120VAC (inrush 2.5A and holding 0.2A). One connects the buffer tank to the helium cylinder to be refilled (solenoid valve #2); a second connects the buffer tank to the return line of the circuit to charge it (solenoid valve #1), and a third joins the supply line to the buffer tank to lower the pressure and store the excess gas (solenoid valve #3).

Title: Cryogenic Subsystem Design Description	Author: D. Urbain	Date: 2023-09-14
NRAO Doc. #: 020.30.10.00.00-0007-DSN		Version: C



Figure 16: Solenoid valve from Clark Cooper, model EH30-041-A120.

4.2.1.4.2 Needle Valve

The purpose of the needle valve is to control the flow of helium in and out of the buffer tank to avoid a rapid change in the circuit's pressure. When the solenoid opens to recharge the circuit from the buffer tank, since it's an ON/OFF valve, it could create a sudden surge in pressure that could affect the compressor. The same is true for releasing overpressure into the buffer tank. Adding the needle valve allows the controller to slowly increase or decrease the pressure without overshooting.

4.2.1.4.3 Buffer Tank

The buffer tank stores helium gas when the pressure in the supply line reaches the upper limit set in the controller and releases that pressure back into the circuit when the pressure gets below the lower limit. The buffer tank is built from an 80 CF cylinder, and a 350 psig relief valve is added for safety.

4.2.1.4.4 Helium Cylinder and Regulator

The helium charge cylinder is of reduced size (shown in Figure 17, next page) to facilitate the replacement on the antenna: one person can carry a full bottle. The model selected is 60 CF size filled with grade 5.5 helium.

Title: Cryogenic Subsystem Design Description	Author: D. Urbain	Date: 2023-09-14
NRAO Doc. #: 020.30.10.00.00-0007-DSN		Version: C



Figure 17: Picture of the buffer tank on the left and the helium charge cylinder on the right.

The pressure regulator (Figure 18) has to be specifically calibrated for the gas in use (helium), rated for the cylinder pressure (min 3000 psig), and able to cover the output pressure range we are interested in (100–300 psig). The regulator will be set to the recommended helium circuit static pressure (200 psig) to charge the circuit remotely to that pressure.



Figure 18: Pressure regulator for helium charge cylinder.

4.2.1.4.5 Controller

For ngVLA, the solenoid valves of the pressure regulation circuit will be controlled by the M505 utility module and the dedicated electronics (“HPRE” in Figure 15). It will allow remote monitoring of the buffer tank pressure and control of the solenoid valves.

Title: Cryogenic Subsystem Design Description	Author: D. Urbain	Date: 2023-09-14
NRAO Doc. #: 020.30.10.00.00-0007-DSN		Version: C

To speed up the development of the pressure regulation prototype for the “green antenna,” three CLICK modules were assembled to build the controller. The assembled controller is easy to program and doesn’t need to interface with the antenna electronics. This solution simplifies installation on the antenna but does not offer remote monitoring and control capability.

- **Power supply:** The C0-01AC power supply (Figure 19) with the following specifications were selected: 100-240VAC nominal input, 24VDC nominal output, 1.3A continuous.

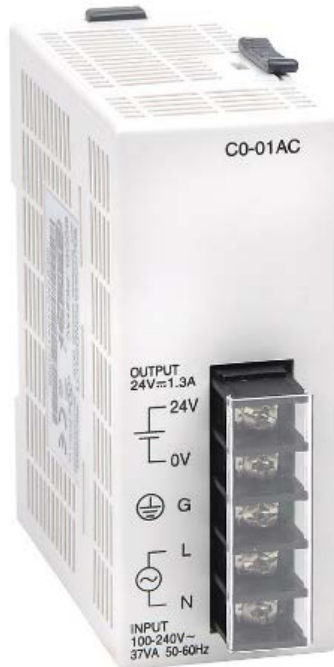

Figure 19: CLICK AC power supply, model C0-01AC.

- **Programmable controller:** The C0-12DD1E-2-D programmable controller (Figure 20) with the following specifications was chosen to control the solenoid valves: 24VDC required, Ethernet and serial ports; discrete input: 4-point, DC; analog input: 4-channel, voltage; discrete output: 4-point, sinking, analog output: 2-channel, voltage.

Title: Cryogenic Subsystem Design Description	Author: D. Urbain	Date: 2023-09-14
NRAO Doc. #: 020.30.10.00.00-0007-DSN		Version: C



Figure 20: Click PLC, model C0-12DD1E-2-D.

- **I/O module:** The relay output module, model C0-08TR (Figure 21), was selected to drive the solenoid. It has 8 output, nominal voltage 6-240VAC/6-27VDC, relay configuration SPST.



Figure 21: CLICK relay module C0-08TR.

4.2.1.5 Vacuum Pump

The vacuum pump will be located inside the auxiliary enclosure to provide protection from the weather. The temperature will not be controlled but some air circulation will be provided to allow the air-cooled vacuum pump to operate without overheating. Two types of pump exist on the market: the dry pump and the oil lubricated pump.

Title: Cryogenic Subsystem Design Description	Author: D. Urbain	Date: 2023-09-14
NRAO Doc. #: 020.30.10.00.00-0007-DSN		Version: C

4.2.1.5.1 Dry Vacuum Pump

Dry vacuum pumps have no oil and rely on tight mechanical tolerances and self-lubricated seals (Teflon) for operation. The scroll pump is the type of interest for ngVLA (Figure 22). The main advantages are that a dry pump can operate in any orientation, and there is no risk of oil back-streaming into the vacuum space, contaminating it. The pump operates following the same scroll compression cycle described for the helium compressor.



Figure 22: Example of dry scroll pump, Agilent IDP-15.

Technical Specifications	IDP-15 Dry scroll Pump
Peak pumping speed	15.4 m ³ /h (4.28 l/s)
Ultimate pressure	10 x 10 ⁻³ Torr
Maximum inlet pressure	1.0 atmosphere
Ambient operating temperature	5°C to 45°C
Voltage	120VAC single-phase 60 Hz
Motor rating	560 W
Operating speed	1750 rpm @ 60 Hz
Weight	34 kg
Dimensions H x W x L	364 mm x 333 mm x 485 mm
Price	\$6,350

Table 9: Specifications of the dry scroll pump Agilent IDP-15.

Title: Cryogenic Subsystem Design Description	Author: D. Urbain	Date: 2023-09-14
NRAO Doc. #: 020.30.10.00.00-0007-DSN		Version: C

4.2.1.5.2 Oil Lubricated Vacuum Pump

Oil pumps rely on oil to create the seals required for gas compression; the oil is also used for lubrication between rubbing surfaces. The VLA has used dual-stage rotary vane pumps for many years, demonstrating excellent reliability. Figure 23 shows the rotary vane pumping cycle.

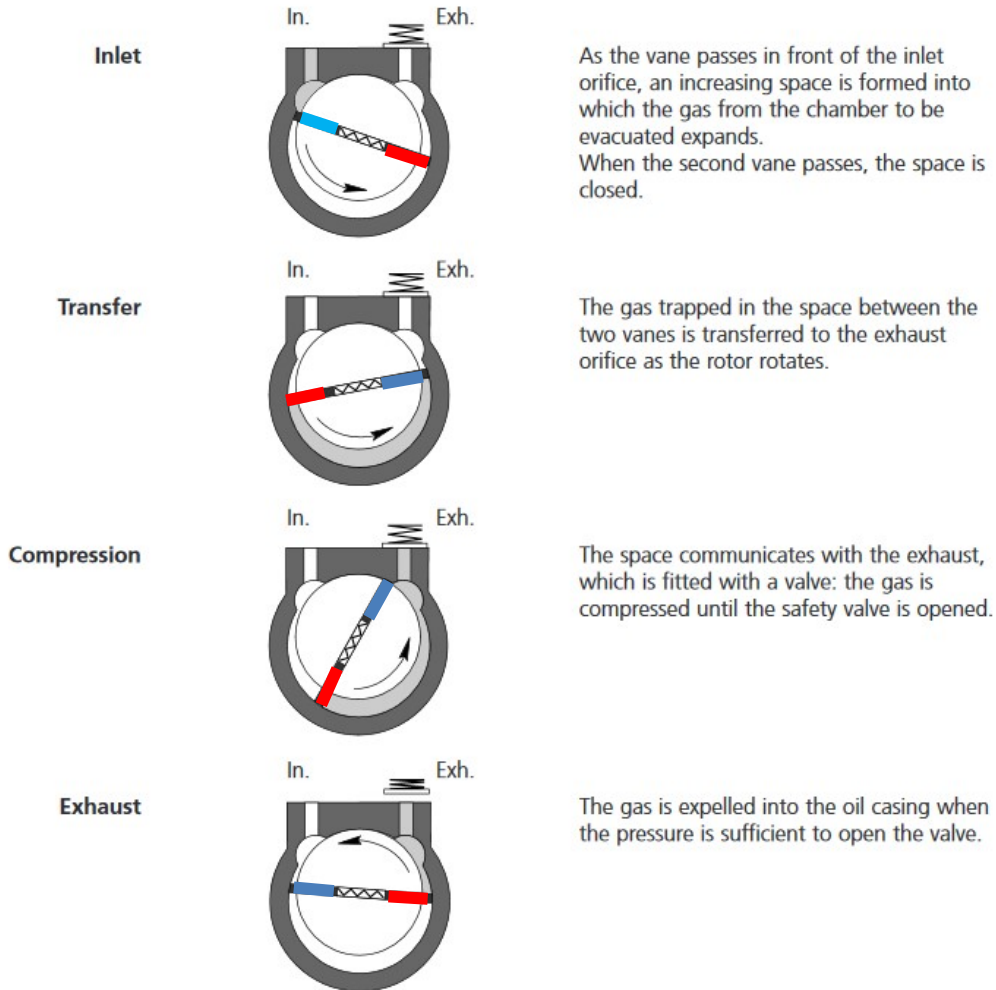

Figure 23: Rotary vane pumping cycle.

The ultimate pressure of a rotary pump can be lowered by connecting two pumping stages in a series. Figure 24 shows how a two-stage pump is built.

Title: Cryogenic Subsystem Design Description	Author: D. Urbain	Date: 2023-09-14
NRAO Doc. #: 020.30.10.00.00-0007-DSN		Version: C

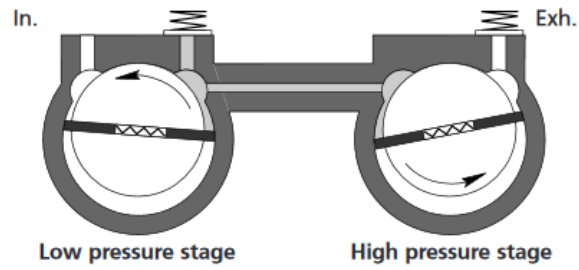

Figure 24: Two-stage rotary vane pump.

An oil-lubricated pump can be operated in varying orientations but only through a limited range. If the range is exceeded, oil will spill out of the pump. The hose connected to the pump cannot be left under vacuum because the oil will backstream into it and could contaminate the vacuum space. A solenoid valve should backfill the hose when the vacuum pump stops. However, the oil pump (Figure 25) has an ultimate pressure one order of magnitude lower than the dry scroll pump, which could be necessary if a long vacuum line separates the pump from the vacuum vessel.



Figure 25: Example of rotary vane vacuum pump, Alcatel Adixen 2021SD.

Technical Specifications	Alcatel Adixen 2021SD Dual Rotary Vane Pump
Peak pumping speed	21 m ³ /h (5.83 l/s)
Ultimate pressure	7.4 x 10 ⁻⁴ Torr
Maximum inlet pressure (continuous operation)	0.1 atmosphere (see oil recovery kit info)
Ambient operating temperature	12°C to 40°C
Voltage	480VAC 3-phase 60Hz

Title: Cryogenic Subsystem Design Description	Author: D. Urbain	Date: 2023-09-14
NRAO Doc. #: 020.30.10.00.00-0007-DSN		Version: C

Motor rating	1022VA
Operating speed	n/a
Weight	28kg
Dimensions h x w x l	240mm x 188mm x 483mm
Price	\$4,210

Table 10: Specifications of the Alcatel Adixen 2021SD rotary vane pump.

When the pump operates at high pressure, the oil heats up, becomes more fluid, and is flushed out of the pump case by the gas stream. To allow the pump to operate for more extended periods at high input pressure (the max pressure remains one atmosphere), an oil mist eliminator and an oil draining kit (Figure 26 and Figure 27) must be used. The high flow of gas passing through carries some oil mist that accumulates in the mist eliminator and is returned to the pump case via the gas ballast opening.



Figure 26: Alcatel Adixen oil mist eliminator OME 25 HP and oil drain kit.

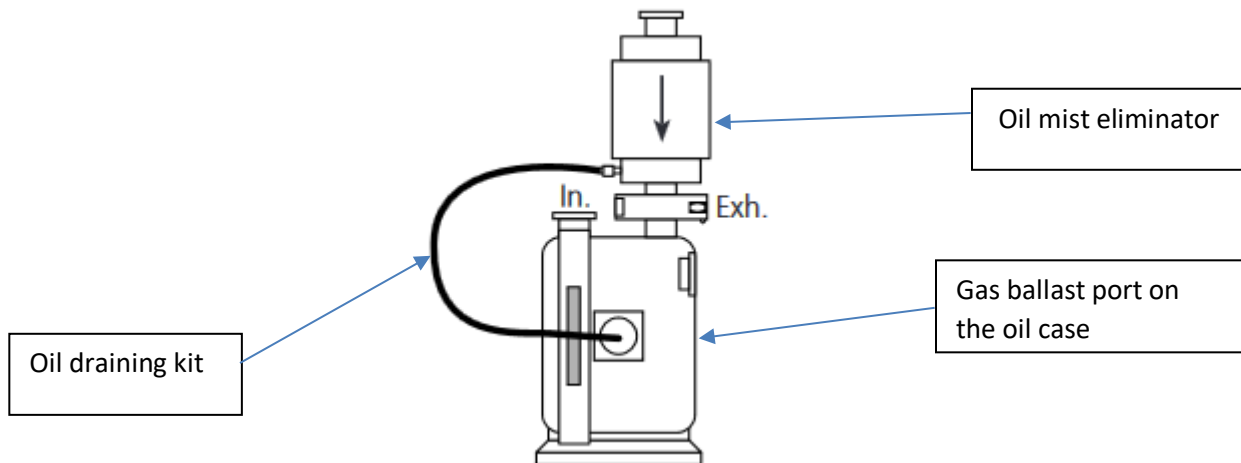

Title: Cryogenic Subsystem Design Description	Author: D. Urbain	Date: 2023-09-14
NRAO Doc. #: 020.30.10.00.00-0007-DSN		Version: C

Figure 27: Rotary vane pump equipped with oil mist eliminator and oil draining kit to recover oil flushed by the gas.

4.2.1.6 Vacuum hose

The vacuum hose connects the vacuum pump in the auxiliary enclosure to the Cryostats A and B in the Front End enclosure. The section of the hose that goes through the cable carrier must be flexible, while the section between the auxiliary enclosure and the junction box can be rigid. The hose shall not collapse under vacuum (14 psi pressure outside pressure applied on the tube wall) to keep the gas flowing during the pump down. The length of the vacuum hose should be kept as short as possible to minimize the pressure drop from the pump to the valve on cryostats A and B, and the diameter has to be as large as practically possible to increase the conductance. A maximum length of 8 meters has been set for both antennas, the 6 meters and the 12 meters, and a hose diameter of 40mm has been selected to provide good conductance while maintaining a reasonably tight dynamic bending radius. The commercial vacuum hoses come in two flavors: metal and PVC.

4.2.1.6.1 Flexible Metal Hose

The flexible metal hose (Figure 28) or bellows is generally made of stainless steel, and the thickness of the metal and the pitch of the corrugation will determine its flexibility and strength. For our application, the hose has to balance flexibility (minimum bending radius) and longevity (resist repetitive bending for the array's life). The manufactured vacuum hoses are usually sold in short sections (1–2 meters max) and are expensive. For example, a two-meter long NW40 hose (1-1/2" internal diameter) with 0.010" thickness is approximately \$400. Some of the key benefits of the metal hose are that they should stay flexible down to low temperatures (−25°C), are recommended for high vacuum, and are not UV sensitive. It is important to note that because of the wall corrugation, their conductance is reduced compared to the smooth reinforced PVC flex, which means that the pressure drop will be more significant for the same length and diameter of the hose.



Figure 28: Flexible metal hose.

For the prototype antenna, the vacuum hose will be built from bulk material purchased from the manufacturer, **Hose Master**. The hose selected is called MASTERFLEX; it has a close pitch corrugation for greater flexibility (dynamic bending radius 230 mm) and comes with a single braid for much-improved working pressure (531 psi versus 28 psi for the unbraided model). Building the vacuum hose out of a single section will reduce the risk of leakage and guarantee more uniform flexibility within the cable carrier.

Title: Cryogenic Subsystem Design Description	Author: D. Urbain	Date: 2023-09-14
NRAO Doc. #: 020.30.10.00.00-0007-DSN		Version: C

4.2.1.6.2 Reinforced PVC Flex Tubing

PVC flexible hoses (Figure 29) are recommended for rough vacuum application (10^{-2} – 10^{-3} Torr). The PVC flexible hose is reinforced with stainless steel wire to resist outside pressure. This hose type has a temperature range of -7°C to 65°C , which could be problematic in the winter. The flexibility of the line will decrease with the temperature, and the PVC might become brittle. Some testing will have to be done to determine if this type of vacuum hose can be used for ngVLA and what the expected life will be.



Figure 29: PVC flex hose reinforced with stainless steel wire.

4.2.1.7 Vacuum Manifold

The manifold connects the flexible vacuum hose from the pump in the auxiliary enclosure to both cryostats A and B inside the Front End enclosure. A Tee splits the incoming line; the input has a KF-40 diameter, while the two outputs have a KF-40 or a smaller diameter of KF-25. A couple of short vacuum hoses connect the Tee to the two vacuum valves that seal each cryostat individually. The valve must be remotely operated to allow pump-down of the cryostat from a distance.

Title: Cryogenic Subsystem Design Description	Author: D. Urbain	Date: 2023-09-14
NRAO Doc. #: 020.30.10.00.00-0007-DSN		Version: C

4.2.1.7.1 Electromagnetically Operated Vacuum Valve

The electromagnetically operated valves that seal the Front End cryostat can be purchased in two opening diameters, NW25 and NW40, as compared in Table 11 and shown in Figure 31.

	Leybold 215079V02	Leybold 215134V02	Ideal Vacuum ElectroMag P107134
Port size	KF-25	KF-40	KF-25
Material	Stainless steel	Stainless steel	Nickel coated Aluminum
Pilot valve	120VAC @ 60Hz	120VAC @ 60Hz	120VAC @ 60Hz
Leak rate	< 1x 10 ⁻⁹ mbar l/s < 1 x 10 ⁻⁹ cc/s	< 1x 10 ⁻⁹ mbar l/s < 1 x 10 ⁻⁹ cc/s	< 1 x 10 ⁻⁹ std cc/s (He)
Vacuum range	7.5 10 ⁻⁹ Torr	7.5 10 ⁻⁹ Torr	10 ⁻⁹ Torr
Molecular flow conductance	14 l/s	45 l/s	3.8 l/s
Service life	200,000 cycles	200,000 cycles	300,000 cycles
Operating temperature	0°C to 50°C	0°C to 50°C	15°C to 40°C
Weight	1.5 kg	2.1 kg	0.73 kg
Dimensions H x W x D	154mm x 48mm x 117mm	182mm x 65mm x 132mm	104mm x 68mm x 59mm
Starting Power	700 Watts (~100ms)	700 Watts (~100ms)	
Holding power	10 Watts	10 Watts	23 Watts
Price	\$2,166	\$2,409	\$470.86

Table 11: List of possible solenoid valves for the Front End Cryostats.

Title: Cryogenic Subsystem Design Description	Author: D. Urbain	Date: 2023-09-14
NRAO Doc. #: 020.30.10.00.00-0007-DSN		Version: C



Figure 30: Oerlikon Leybold Right angle NW40, 120 VAC valve, PN 215134V02.

The larger diameter valve from Leybold is physically big and expensive but offers ten times the conductance of the much less costly Ideal Vacuum valve. A higher conductance means a reduced pump-down time in principle. However, the nominal pumping speed of the pump itself is only 6 l/s, and the length of the vacuum hose, Tee, and adapter restrict the conductance ahead of the valve.

A simplistic calculation of the conductance of the vacuum line between the pump and the cryostats shows only a 37% improvement for the Leybold KF-40 over the Ideal Vacuum KF-25 (Table 12).

	Leybold KF-25	Leybold KF-40	Ideal Vacuum KF-25
Vacuum hose 3m long KF-40	5.16 l/s	5.16 l/s	5.16 l/s
Tee input KF-40 output KF-40* (arms 65mm)	7.8 l/s	7.8 l/s	7.8 l/s
Vacuum hose 0.75m long KF-40	10.32 l/s	10.32 l/s	10.32 l/s
Transition KF-40 to KF-25 (4cm long)	93.2 l/s	n/a	93.2 l/s
Valve	14 l/s	45 l/s	3.8 l/s
Total conductance	2.00 l/s	2.27 l/s	1.44 l/s

Table 12: Simplistic (back of the envelope) conductance calculation of the vacuum line between the pump and the cryostats.

* Note: Because I don't have a formula to calculate the conductance of a Tee, for the estimation I calculated the conductance of a 90° elbow and divided the value by two.

Title: Cryogenic Subsystem Design Description	Author: D. Urbain	Date: 2023-09-14
NRAO Doc. #: 020.30.10.00.00-0007-DSN		Version: C

The effective pumping speed (Table 13) is calculated with the following formula:

$$1/S = 1/S_p + 1/C \text{ or } S = 1/[(1/S_p)+(1/C)]$$

where:

- S = Effective pumping speed
- S_p = Speed of the pump in liters/second
- C = Conductance in liters/second

	Leybold KF-25	Leybold KF-40	Ideal Vacuum KF-25
IDP-15 Dry scroll Pump $S_p = 4.28 \text{ l/s}$	1.36 l/s	1.48 l/s	1.08 l/s
Alcatel Adixen 2021SD $S_p = 5.83 \text{ l/s}$	1.49 l/s	1.64 l/s	1.15 l/s
Alcatel Adixen 2010SD $S_p = 2.78 \text{ l/s}$	1.16 l/s	1.25 l/s	0.95 l/s

Table 13: Simplistic (back of the envelope) pumping speed calculation for two different vacuum pumps.

4.2.2 Monitoring and Control

4.2.2.1 Monitoring

The cryogenic subsystem will be operated remotely in order to monitor the health of the system and predict failure to schedule maintenance. The following parameters must be monitored and recorded.

- Helium pressure
 - Supply line
 - Return line
 - Pressure regulation buffer tank
 - Pressure regulation charging cylinder
- Vacuum pressure
 - Vacuum hose right after the pump
 - Vacuum manifold before the Tee
 - Cryostat A (External, sensor belongs to Front End Cryostat A)
 - Cryostat B (External, sensor belongs to Front End Cryostat B)
- Temperature of the helium compressor
 - Top of Scroll capsule
 - Oil discharge
 - Helium gas discharge

Title: Cryogenic Subsystem Design Description	Author: D. Urbain	Date: 2023-09-14
NRAO Doc. #: 020.30.10.00.00-0007-DSN		Version: C

- Oil return after the heat exchanger
- Glycol input temperature
- Glycol output temperature
- Temperature of the cold head cryostat A
 - Motor
 - First stage (2 sensors for redundancy)
 - Second stage (2 sensors for redundancy)
- Temperature of the cold head cryostat B
 - Motor
 - First stage (2 sensors for redundancy)
 - Second stage (2 sensors for redundancy)
- Temperature of the vacuum pump
- Noise emitted by cold heads
 - Acoustic sensor cold head cryostat A
 - Acoustic sensor cold head cryostat B
- Running hours
 - Compressor
 - Cold head cryostat A
 - Cold head cryostat B
 - Vacuum pump
- Operating speed
 - Compressor
 - Cold head cryostat A
 - Cold head cryostat B
- Valve position open/closed
 - Cryostat A valve
 - Cryostat B valve
 - Pressure regulation module valves
 - From supply line to buffer tank
 - From buffer tank to return line
 - From charging bottle to buffer tank

4.2.2.2 Control

The following parameters of the cryogenic subsystem shall be controllable remotely.

- ON/OFF
 - Compressor
 - Cold head cryostat A



Title: Cryogenic Subsystem Design Description	Author: D. Urbain	Date: 2023-09-14
NRAO Doc. #: 020.30.10.00.00-0007-DSN		Version: C

- Cold head cryostat B
- Vacuum pump
- Helium pressure regulation module
- Running speed
 - Compressor
 - Cold head cryostat A
 - Cold head cryostat B
- Open/closed
 - Cryostat A solenoid valve
 - Cryostat B solenoid valve
 - Helium pressure regulation valves
 - Supply line to buffer tank
 - Return line to buffer tank
 - Charging cylinder to buffer tank
- Oil warmer
 - Compressor oil warmer ON/OFF
 - Vacuum pump oil warmer ON/OFF

4.2.3 Functional Diagram

The functional diagram (Figure 31, next page) provides an overview of the signal path for the cryogenic subsystem. The information from other subsystems is at the bottom of the diagram, and the outgoing information is at the top. The M&C electronics will be divided into three modules: one in the antenna turn head (18m), one in the auxiliary enclosure, and the last one in the Front End enclosure.

Title: Cryogenic Subsystem Design Description	Author: D. Urbain	Date: 2023-09-14
NRAO Doc. #: 020.30.10.00.00-0007-DSN		Version: C

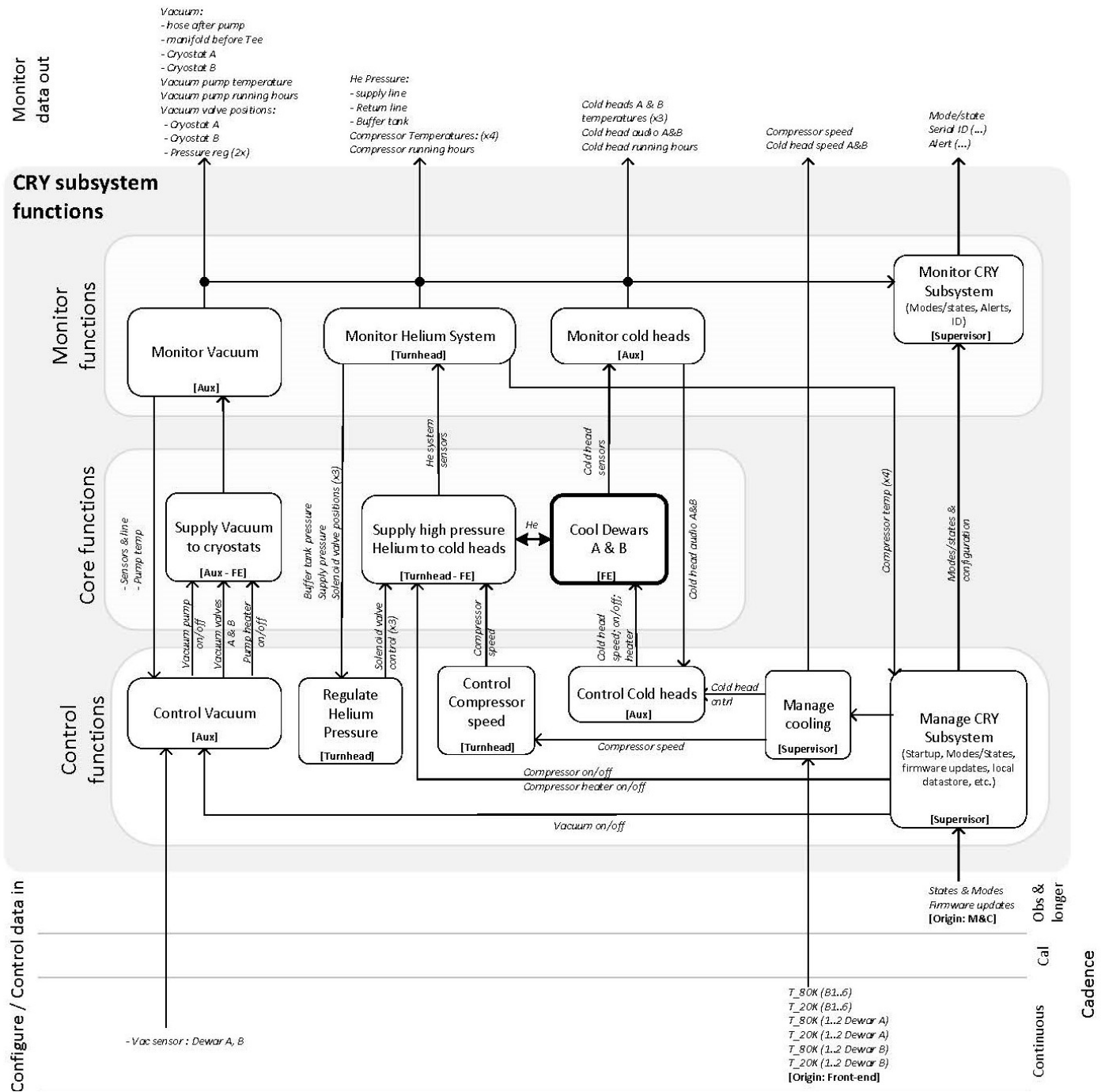

Figure 31: Cryogenic subsystem functional diagram.

4.2.3.1 Control Functions



Title: Cryogenic Subsystem Design Description	Author: D. Urbain	Date: 2023-09-14
NRAO Doc. #: 020.30.10.00.00-0007-DSN		Version: C

4.2.3.1.1 Manage CRY Subsystem

- Will access cryostats A & B monitored temperatures.
- Will access cryostats A & B monitored vacuum pressures.
- Will access cryogenic subsystem monitored information.
- Will send commands to compressor, cold heads, pressure regulation and vacuum pump controllers.

4.2.3.1.2 Control Compressor Speed

- Will start and stop the compressor.
- Will adjust the compressor speed to maintain cooling performance while keeping the power consumption to the minimum.
- Will turn on the oil warmers before starting the compressor in cold weather.

4.2.3.1.3 Control Cold Heads

- Will start and stop the cold heads independently for cryostats A & B.
- Will adjust the speed of the cold heads independently for cryostats A & B.
- Will actively control the second stage temperature of Cryostats A & B.
- Will apply heaters to warmup cryostats A & B independently.

4.2.3.1.4 Regulate Helium Pressure

- Will open and close the solenoid to the buffer tank base on the supply pressure values.
- Will open and close the solenoid to the return line base on the supply pressure values.
- Will open and close the solenoid to the charge bottle base on the buffer tank pressure.

4.2.3.1.5 Control Vacuum

- Will start and stop the vacuum pump.
- Will turn on the oil warmers before starting the pump in cold temperature.
- Will open and close the cryostats A & B solenoids independently while monitoring the vacuum line pressure.

4.2.3.2 Monitor Functions

4.2.3.2.1 Monitor CRY Subsystem

- Will store critical cryogenic subsystem information: serial number, in service dates, running hours.
- Will collect monitored information from cold heads, helium circuit and vacuum monitors.

4.2.3.2.2 Monitor Cold Heads

- Will monitor cold head speed, temperatures and audio sensors for cryostats A & B.

4.2.3.2.3 Monitor Helium Circuit

- Will monitor the compressor speed temperatures, pressures and running hours.
- Will monitor the helium pressure regulation module buffer tank pressure and charging cylinder pressures and solenoid valve positions

Title: Cryogenic Subsystem Design Description	Author: D. Urbain	Date: 2023-09-14
NRAO Doc. #: 020.30.10.00.00-0007-DSN		Version: C

4.2.3.2.4 Monitor Vacuum

- Will monitor vacuum pump oil temperature, running hours.
- Will monitor the vacuum line pressures.
- Will monitor the cryostats A & B solenoid valve positions.

4.2.4 Electronic Design

4.2.4.1 Compressor Drive Electronics

The compressor capsule will be powered by 3-phase 480VAC or 208VAC for higher efficiency than a single-phase model. Power to the compressor capsule will be provided by a commercial variable-speed AC drive for the induction motor (VFD) to change the running frequency and adjust the compressor output flow to match the demand from the two cryocoolers. Figure 32 shows a block diagram of this system.

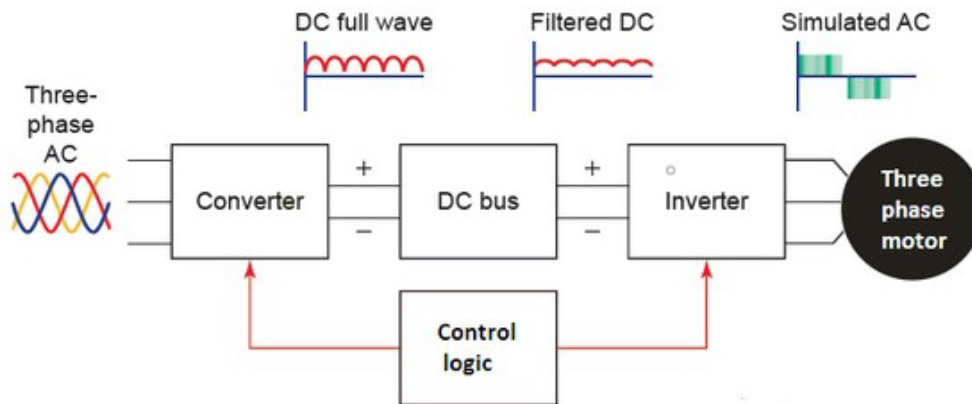
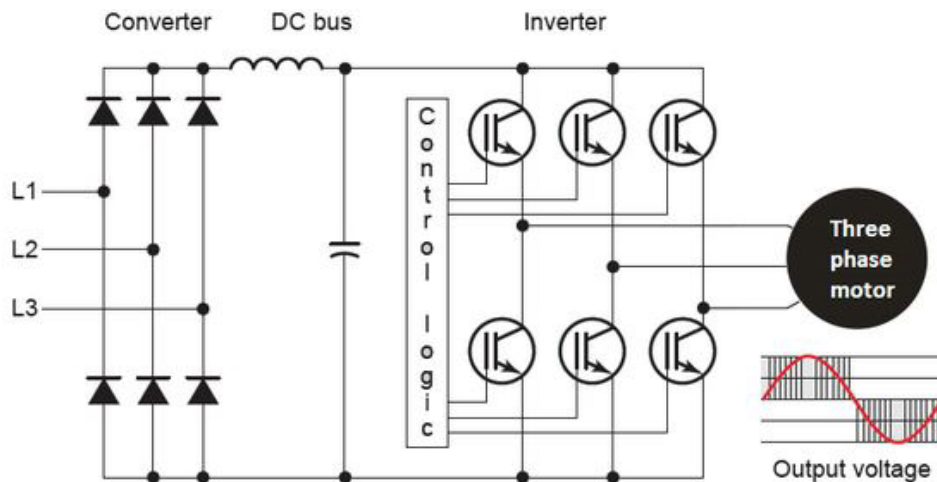

Figure 32: VFD block diagram (copied from yourelectricalguide.com).

The VFD will control the speed and torque of the scroll capsule motor. The fixed voltage and frequency AC input is rectified, filtered, and inverted back to AC at the desired frequency and amplitude (Figure 33).



Title: Cryogenic Subsystem Design Description	Author: D. Urbain	Date: 2023-09-14
NRAO Doc. #: 020.30.10.00.00-0007-DSN		Version: C

Figure 33: VFD electrical schematic (copied from yourelectricalguide.com).

The control electronics generate the pulse sequence necessary to switch the power transistors in the inverter block to create the new AC power. To reduce the harmonic distortion on the generated voltages, some load reactor elements are placed at the output of the inverter to absorb voltage spikes and filter harmonics to clean the waveform and prevent damage to the compressor motor.

4.2.4.2 Cryocooler Drive Electronics

The cryocoolers will also be operated at variable speeds to adjust their cooling power to match their thermal load, prolong the service intervals, or speed up the cooldown time. The target temperature on the second stage is 20K for the optimum performance of the low noise amplifiers. The drive electronics will control the speed of the cryocooler to maintain this temperature. The fast temperature variations that the speed of the cold head cannot regulate will be suppressed by an active control loop.

The motor driving the displacer and/or the valve assembly of the GM cryocooler could be a stepper motor or an AC synchronous motor, and the drive electronics will be designed accordingly.

4.2.4.2.1 Driver for AC Synchronous Motor

The Trillium 350 cold head (Figure 34) uses an AC synchronous motor to drive the displacer and actuate the valves. To run, the motor requires two AC voltages with a 90° phase difference. A Scott-T transformer was used to generate the voltages for the VLA, but a variable-speed drive was developed internally within the scope of the green antenna project.

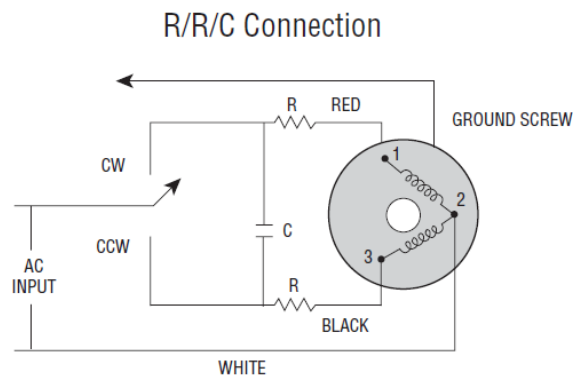

2 - Number in diagrams represent terminal connection when motors are supplied with terminal boards.

Two-Phase Operation

Figure 34: Trillium 350 2-phase AC synchronous motor, 72rpm at 60 Hz, 120VAC 2-phase power.

The stator has eight salient poles with a two-phase, four-pole winding. The stator teeth are set at a pitch of 48 teeth for a full circle, although there are actually only 40 teeth, as one tooth per pole has been eliminated to allow space for the windings: $(60 \text{ Hz} \div 48 \text{ teeth/circle}) \times 60 \text{ s/min} \sim 72 \text{ rpm}$.

The Sumitomo cold CH-204SFF (Figure 35) also uses an AC synchronous motor but needs 208 VAC 3-phase power. At the nominal 60 Hz operating frequency, the motor turns at 72 rpm. The VFD designed to drive

Title: Cryogenic Subsystem Design Description	Author: D. Urbain	Date: 2023-09-14
NRAO Doc. #: 020.30.10.00.00-0007-DSN		Version: C

the Trillium motor can be modified to run the Sumitomo; the electronics wave generation portion should be identical but with an additional third waveform and a 120° phase shift instead of 90°. Six power transistors are needed to generate the three driving voltages, while only four will drive the Trillium cold head.

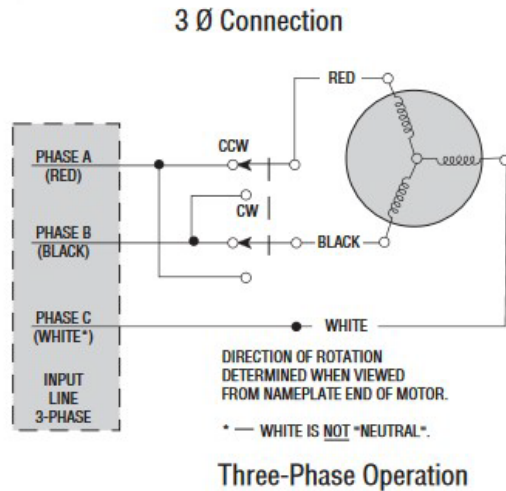

Figure 35: Sumitomo CH-204SFF 3-phase AC synchronous motor, 72 rpm at 60 Hz, 208VAC 3-phase.

4.2.4.2.2 Driver for Stepper Motor

Oxford Cryosystems uses a stepper motor (Figure 36) to move the valve in their cold heads. The speed of the stepper motor driving the valve is adjustable so that the cryocooler can operate at variable speeds from 40-90 rpm.

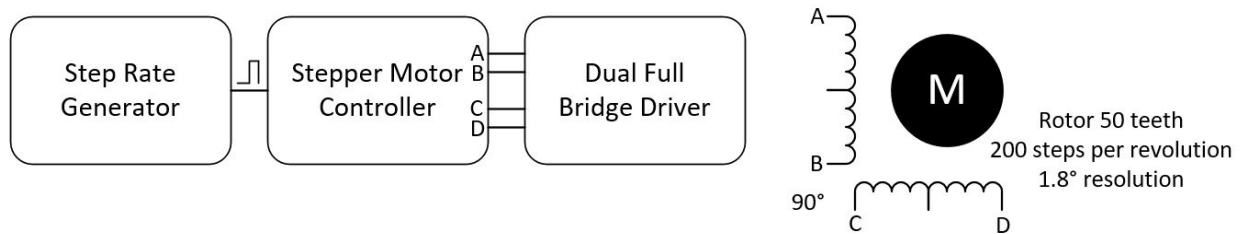

Figure 36: Oxford Cryosystems stepper motor drive schematic.

The stepper motor selected is called a hybrid stepper motor, where the rotor is composed of a permanent magnet encapsulated inside two 50-tooth steel caps offset by one tooth. The tooth pitch is 7.2°, but it takes four steps to rotate by one tooth, giving an angular resolution of 1.8°. The motor is driven by two windings operated in half-step mode to double the angular resolution, and the current is kept constant.

4.2.5 Mechanical Design

The mechanical design is essential because the cryogenic subsystem must interface with the antenna and the Front End cryostat.

4.2.5.1 Helium Compressor

Title: Cryogenic Subsystem Design Description	Author: D. Urbain	Date: 2023-09-14
NRAO Doc. #: 020.30.10.00.00-0007-DSN		Version: C

The compressor weight, physical dimensions, and power dissipation had to be defined early because the antenna manufacturer has to ensure the proper volume is reserved, the structure can support the weight, and adequate cooling is provided. The information provided came from the reference design configuration where a Sumitomo FA-70 enclosure was used for mass and volume, and the power dissipation came from the [CRY1001] requirement.

Since then, the 18m antenna concept has relocated the compressor inside the turn-head, and a liquid-cooled configuration has been selected as the preferred option. Consequently, the requirements for both antennas are different.

4.2.5.1.1 18m Antenna

Clearance Volume W x H x D	Mass	Power dissipation
1650 mm x 1150 mm x 1550 mm	110 kg	5.54 kW

4.2.5.1.2 6m Antenna

Clearance Volume W x H x D	Mass	Power dissipation
1666 mm x 1148 mm x 1691 mm	172 kg	5.54 kW

4.2.5.2 Helium Pressure Regulation Module

The helium pressure regulation volume and mass were derived from the prototype built for the VLA green antenna project. It was agreed that the supply and buffer tank could be separated from the control box to help with the placement on the antenna.

4.2.5.2.1 18m antenna

The prototype antenna places the pressure regulation module inside the turn-head and decouples the buffer tank and the charge cylinder from the control box. Therefore, two sets of requirements are needed.

- Buffer tank and charge cylinder assembly

Clearance Volume W x H x D	Mass	Power dissipation
600 mm x 1050 mm x 972 mm	59 kg	n/a

Title: Cryogenic Subsystem Design Description	Author: D. Urbain	Date: 2023-09-14
NRAO Doc. #: 020.30.10.00.00-0007-DSN		Version: C

- Control box

Clearance Volume W x H x D	Mass	Power dissipation
600 mm x 470 mm x 540 mm	19 kg	< 100 W

4.2.5.2.2 6m antenna

At this time no information is available on the 6m antenna, the initial requirement applies.

Clearance Volume W x H x D	Mass	Power dissipation
600 mm x 1550 mm x 1478 mm	78 kg	< 100 W

4.2.5.3 Compressor Electronics RFI Enclosure

To simplify the RFI shielding, it was decided that the compressor control and power electronics would be placed in a separate RFI enclosure. The RFI enclosure must be close to the compressor to minimize ohmic loss through cables.

Clearance Volume W x H x D	Mass	Power dissipation
740 mm x 425 mm x 1698 mm	60 kg	1,550 W

The 1,550 W is an estimated value that must be refined later during the design phase. The heat dissipated inside the enclosure must be removed by a cold plate connected to the glycol circuit for the 18m antenna. For the 6m antenna, if the enclosure is sitting outside, air-cooled is an option.

4.2.5.4 Helium Lines

The helium lines will have to be routed from the compressor all the way to the Front End enclosure. The rigid sections will be attached to the antenna structure, while flexible lines will be used through the elevation wrap and the cable carrier.

Line Type	Outer Diameter	Weight	Minimum Bending Radius
Rigid	20 mm	0.6 kg/m	50 mm
Flexible	40 mm	2.0 kg/m	250 mm

4.2.5.5 Cold Heads

Clearance Volume W x H x D	Mass	Power dissipation
TBD	15 kg	200 W



Title: Cryogenic Subsystem Design Description	Author: D. Urbain	Date: 2023-09-14
NRAO Doc. #: 020.30.10.00.00-0007-DSN		Version: C

The 200 W power dissipation is an estimated value; for example, the AC synchronous motor used on the Trillium 350 cold head uses only 0.6A when powered by a single-phase 120 VAC and an RC network to generate the second phase. The heat dissipated by the cryostat A & B cold heads will exhaust inside the Front End enclosure. How the temperature inside the enclosure will be controlled is to be determined.

4.2.5.6 Vacuum Pump

The vacuum pump will be placed inside the auxiliary enclosure and mounted tilted to prevent oil spill regardless of the antenna elevation angle. The pump is designed to be air-cooled but it might be modified if liquid cooling is preferred.

Clearance Volume W x H x D	Mass	Power dissipation
TBD	35 kg	600 W

4.3 Performance Budgets

One essential requirement for the cryogenic subsystem is cooling capacity. Estimated values were derived from thermal calculations on early Front End cryostats A and B versions. It was decided that both cryostats would use the same cryocooler. Therefore, the one with the highest thermal load determined the size of the cryocooler.

Cryostat B has the highest thermal load; it contains five frequency bands. The total allocated thermal load can be divided between the bands to give each one a maximum value to keep the full loads within range (Table 14, next page).

The Stage 1 thermal load does not account for the radiative load onto the radiation shield wrapped with a 30-layer MLI blanket. When the thermal gap is covered with MLI, the load is estimated at 3,150 milliwatts (mW).

Stage 1	Band 2 mW	Band 3 mW	Band 4 mW	Band 5 mW	Band 6 mW	Total mW
Thermal gap via strap to copper bus	1030	840	710	580	540	
Radiation shield to aluminum support	1660	990	740	350	340	
Power divider and wires, coax/WG strappings	120	60	30	390	220	
Total	2810	1890	1480	1320	1100	8600

Title: Cryogenic Subsystem Design Description	Author: D. Urbain	Date: 2023-09-14
NRAO Doc. #: 020.30.10.00.00-0007-DSN		Version: C

Stage 2	Band 2 mW	Band 3 mW	Band 4 mW	Band 5 mW	Band 6 mW	Total mW
OMT thermal strap	1120	420	190	120	70	
LNA-A thermal strap	n/a	240	210	110	80	
LNA-B thermal strap	n/a	440	210	160	120	
Total	1120	1100	610	390	270	3490

Table 14: Cryostat B thermal load distribution among frequency bands for Stages 1 and 2.

The total estimated loads for Cryostat B are **11750 mW on Stage 1** (8600 + 3150) and **3490 mW on Stage 2** of the cryocooler.

4.4 Environmental Protection

Some cryogenic subsystem components will be exposed to the environment, and others will be protected by the antenna structure or an enclosure. The compressor location will likely differ for the 18m and 6m antennas. Table 15 lists the original cryogenic subsystem environmental requirements for normal operation. Some of the requirements are only relevant for components located outside.

Parameter	Summary of Requirement	Reference Requirement
Temperature range for normal operation	The cryogenic subsystem shall perform normally in the temperature range of $-25^{\circ}\text{C} \leq T \leq 45^{\circ}\text{C}$.	CRY0002
Altitude range	The cryogenic subsystem shall operate normally at altitudes ranging from sea level up to 2500 m.	CRY0020
Precipitation for normal operation	The cryogenic subsystem shall perform normally for rainfall of 5 cm/hour over 10 minutes.	CRY0003
Ice accumulation for normal operation	No ice accumulation shall be present on moving parts of the cryogenic subsystem for normal operation, but equivalent to radial ice of 2.5 mm on static surfaces is acceptable.	CRY0004
Wind speed limits for normal operation	The cryogenic subsystem shall perform normally for wind speed $0 \text{ m/s} \leq W \leq 30 \text{ m/s}$ average.	CRY0001

Table 15: List of environment requirements for the cryogenic subsystem.

4.4.1 Temperature Range

4.4.1.1 Compressor

This requirement is the most challenging, and the low temperature is the most problematic. The oil's viscosity inside the compressor or the vacuum pump will increase as it gets colder, affecting its ability to circulate, cool the motors, and lubricate the moving parts. The most common solution is to add a heating element to the compressor or pump to warm the oil and allow operation in cold temperatures.



Title: Cryogenic Subsystem Design Description	Author: D. Urbain	Date: 2023-09-14
NRAO Doc. #: 020.30.10.00.00-0007-DSN		Version: C

Sumitomo’s outdoor-rated compressor, the FA-70, uses a clever oil management circuit to enable the oil to bypass the heat exchange in cold weather and extend the temperature range down to -30°C .

For an air-cooled compressor, having a multi-speed fan is essential because the fan could run at low speed or even stop when the outside temperature is frigid. Because the VLA compressors have a constant speed fan, part of the heat exchange must be blocked off during winter to reduce cooling and keep the compressor at the correct operating temperature.

The selected 18m antenna design has the compressor inside the turn head. It is highly desirable to have an environmental control system that will limit the temperature variations of the air inside the structure. The liquid-cooled compressor configuration is preferred because of the smaller volume requirement, simplified installation, better accessibility, and reduced estimated maintenance. The liquid-cooled compressor selected for evaluation has a minimum operating ambient temperature specification of $4-5^{\circ}\text{C}$.

The temperature will not be an issue if the compressor runs because the heat dissipated will keep everything warm inside the enclosure. The ambient temperature before start-up is a problem. If the compressor has been sitting in cold temperatures for an extended period, the oil will be cold with a thick consistency like molasses. Starting the compressor when the oil is more viscous is not recommended because the oil will not flow very well, affecting cooling and lubrication. It could also offer too much resistance to the mechanical movement of the scrolls, increasing the current load to the point where it could trip the breaker. The capsule will overheat quickly if the oil fails to circulate through the system as expected. At that point, the over-temperature protection circuit will shut down the compressor. Therefore, the oil must be warmed up before the compressor can be safely started. Three solutions are possible to bring the oil to the required temperature:

- Install oil warmers on the compressor capsule to heat the oil.
- Use the glycol loop to warm up the compressor assembly and the oil it contains. This solution requires the glycol temperature to be above 5°C .
- The air inside the antenna structure can be heated to above 5°C to warm up the equipment.

Combining the listed options will accelerate the warm-up procedure and allow the compressor to be started quicker, but the oil warmer is likely the most effective solution.

The 6m antenna design doesn’t exist yet, but the compressor will probably have to be outside due to the smaller structure. The compressor will have to be engineered to cover the entire temperature range.

4.4.1.2 *Vaccum Pump*

Unlike the compressor, the vacuum pump will usually sit idle; it will only run to evacuate the Front End cryostat(s) before starting the cool-down. The vacuum pumps are designed for indoor use and have a minimum ambient temperature of 12°C . This requirement is imposed by the oil that will not have the proper fluidity at lower temperatures and will compromise the operation of the vacuum pump. Unless the temperature inside the auxiliary enclosure is regulated, the vacuum pump must have an oil pump heater/crankcase heater to warm up the oil before the pump is started when the ambient temperature is below 12°C . Suppose the vacuum pump is the only component inside the auxiliary enclosure that needs a

Title: Cryogenic Subsystem Design Description	Author: D. Urbain	Date: 2023-09-14
NRAO Doc. #: 020.30.10.00.00-0007-DSN		Version: C

warm environment. In that case, it seems more cost-effective to warm up the pump when needed and not keep the entire enclosure temperature-controlled.

If a dry vacuum pump is selected, the body of the pump will have to be warmed up before the pump is operated when the ambient temperature drops below 5°C. I believe the requirement comes from the seals that might be too rigid at low temperatures and could wear out prematurely.

4.4.2 Altitude

The altitude requirement should be met with standard cryogenic equipment. The most common problem is reduced heat dissipation due to the lesser air density. The electronics can be designed to account for the altitude by derating the power supplies; for example, see Table 16.

(Thermal derating above 2000m = 1°C per 305 m (1000 ft))

Temperature rise multipliers for high altitudes			
Altitude	Multiplier		
m(ft)	Fan-cooled (general)	Fan-cooled (high power)	Naturally cooled
0 (sea level)	1	1	1
1,500(5,000)	1.2	1.16	1.1
3,000(10,000)	1.45	1.35	1.21
4,500(15,000)	1.77	1.58	1.33
6,000(20,000)	2.18	1.86	1.48

Table 16: Design temperature derating at altitude.

4.4.3 Precipitation

The proposed design for the 18m antenna has the compressor and helium pressure regulator inside the antenna turn-head, therefore protected from rain. However, the 6m antenna might have the compressor outside and exposed to the elements. If this is the case, a compressor specific to the 6m antenna will likely have to be procured. Sumitomo has the FA-70 outdoor enclosure, and Oxford Cryosystems has the K450-AC3 developed for the SKA project. Both compressors are designed for outdoor applications and have passed water ingress testing. Both compressors provide a good starting platform for an outdoor compressor.

4.4.4 Ice Accumulation

For the 18m antenna, ice accumulation is not an issue because of the indoor location of the compressor, but this might be a concern for the 6m antenna. The solution adopted by the ALMA project was to protect the compressor with an enclosure to avoid ice accumulation on the compressor itself.



Title: Cryogenic Subsystem Design Description	Author: D. Urbain	Date: 2023-09-14
NRAO Doc. #: 020.30.10.00.00-0007-DSN		Version: C

Ice could become a problem for the flexible helium lines as well. One solution is to add a waterproofing sleeve to protect the thin-walled stainless steel corrugated core. The brackets holding the rigid lines along the antenna structure must be strong enough to support the weight of the lines plus that of the ice layer.

4.4.5 Wind Protection

On the 6m antenna, the same enclosure that will protect the compressor from the ice could be designed to shield it from high wind. The ALMA enclosure has some louvers in front of the compressor heat exchanger for wind protection.

The rigid helium lines shall be secured to the antenna structure with heavy-duty clamps, placed at short enough intervals to prevent resonance vibrations from developing with the wind.

4.5 RFI, EMC, and Lightning Protection

4.5.1 RFI/EMC Protection

The control electronics for the compressor, cold heads, and helium pressure regulation module are susceptible to generating RFI. RFI enclosures and/or shielding will be provided to keep emission levels below the ngVLA threshold values. A suitable enclosure should provide at least 30 dB of attenuation. All equipment must be tested for EMI/RFI before it is installed on the antenna.

Several compressors equipped with VFD have been tested in the VLA reverberation chamber, and the measured RFI levels exceeded the VLA requirement. Therefore, we have decided to install all compressor electronics in a separate shielded enclosure because it will be easier than shielding the compressor enclosure.

Figure 37 shows the measured RFI emissions of a prototype variable-speed Sumitomo compressor for ALMA. The compressor passes the ALMA requirement but not the VLA ones (curved dotted line).

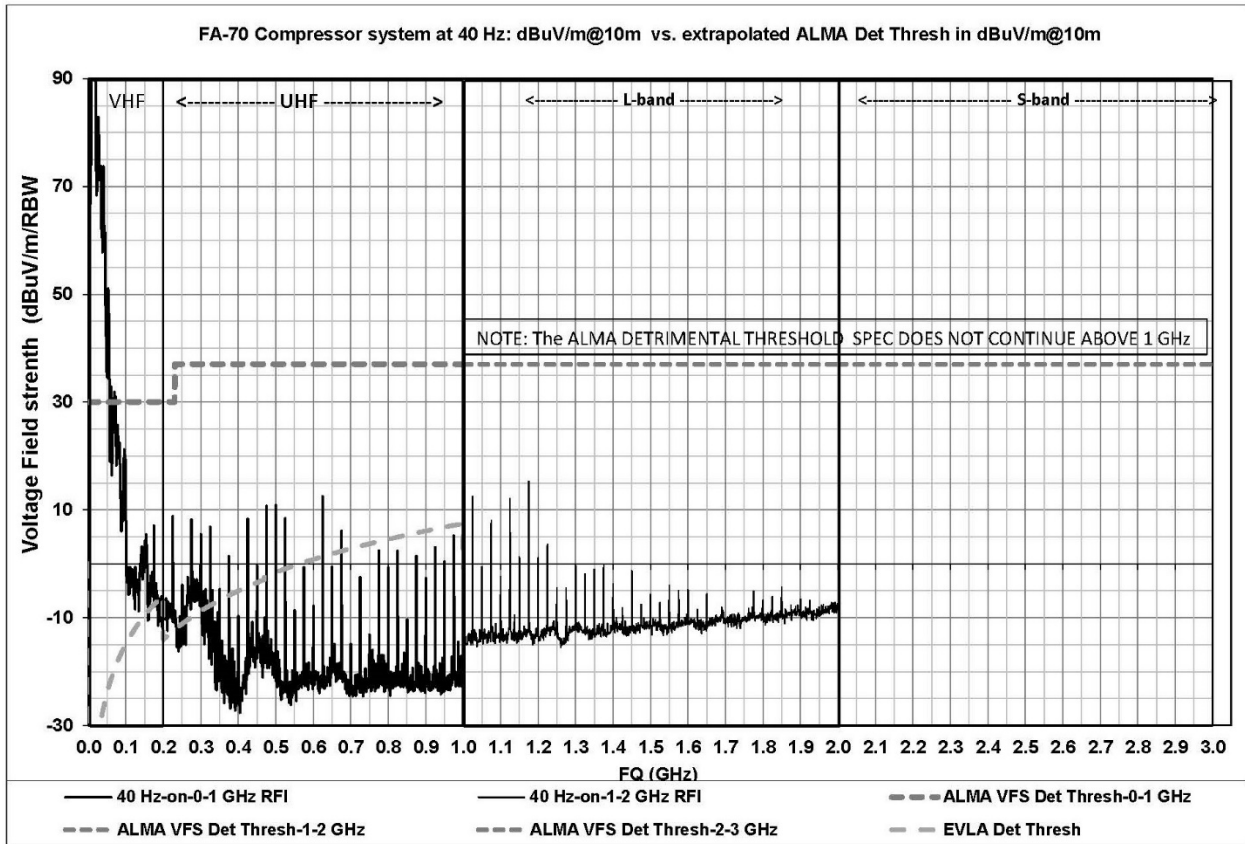

Figure 37: EMI/RFI measurement of the Sumitomo FA-70 compressor with VFD operating at 40 Hz.

Table 17 lists the detrimental emission thresholds (EIRP(dBm)/Hz) at 10 meters for the VLA and for ngVLA. It is important to note that ngVLA does not have a requirement below 1 GHz (information provided by Dan Mertely).

Freq (GHz)	1	2	4	6	8	10	20	30
VLA								
EIRP (dBm@ 10m)/Hz	-156.6	-150.6	-144.6	-141.1	-137.8	-135.8	-128.6	-124.6
ngVLA								
EIRP (dBm@ 10m)/Hz	-152.5	-146.8	-140.8	-137.4	-135.3	-133.5	-126.5	-122.7

Table 17: Detrimental emission threshold values for the VLA and ngVLA between 1–30 GHz.

Note: between 1 GHz and 6 GHz the detrimental emission threshold for ngVLA is approximately 4 dB higher than the VLA values.



Title: Cryogenic Subsystem Design Description	Author: D. Urbain	Date: 2023-09-14
NRAO Doc. #: 020.30.10.00.00-0007-DSN		Version: C

4.5.2 Lightning Protection

Most lightning protection will be provided by adequately grounding the equipment to the antenna structure and grounding bus. Having the compressor and the cryocoolers enclosed will help alleviate the risks associated with lightning strikes.

Because not every section of the antenna has the same lightning exposure level, various lightning protection zones will be defined. Each zone will have a specific surge protection requirement level that the cryogenic equipment in that section must meet. The antenna lightning zones will be determined during the preliminary design phase.

4.6 Power Supply and Distribution

The DC voltage required to run the various M&C electronics will be provided by the power supply board integrated inside the utility modules (M500 series) or generated locally.

The antenna will provide the AC power. 480VAC 3-phase will be used whenever possible for lower current specifications and smaller wiring gauge requirements.

4.7 Reliability, Availability, and Maintainability

Table 18 lists key requirements for reliability, availability, and maintenance of the cryogenic subsystem.

Parameter	Summary of Requirement	Reference Requirement
Design life	The cryogenic subsystem shall be designed for an expected operational life of no less than 30 years.	CRY0600
Part selection for maintainability	The manufacturer of the compressor and cold head shall support their equipment and have sufficient spare parts inventory for the design life of the instrument (30 years).	CRY0601
MTBM	The cryogenic subsystem shall be designed with an expected MTBM for the entire subsystem of 8,333 hours.	CRY0100
Serviceable onsite	The cold head shall be serviceable/swappable onsite (antenna) by one technician within 2 hours.	CRY0109

Table 18: Key requirements linked to reliability, availability, and maintenance.

4.7.1 Reliability

As much as possible, the cryogenic subsystem will use Commercial Off-the-Shelf (COTS) components that have demonstrated high reliability over many years of operation. The GM cryocoolers have been used in radio astronomy and the semiconductor industry for many decades, and reliability data should be readily available from the manufacturers.

Custom electronics will, as much as possible, use components from the approved list established for the project.

Helium lines will use high-quality materials and fittings from reputable suppliers.



Title: Cryogenic Subsystem Design Description	Author: D. Urbain	Date: 2023-09-14
NRAO Doc. #: 020.30.10.00.00-0007-DSN		Version: C

4.7.2 Availability

The use of COTS components should guarantee availability; the delivery schedule will be discussed and agreed upon with suppliers before establishing production contracts. The delivery schedule will be arranged to precede the antenna delivery schedule to avoid any delay.

4.7.3 Maintainability

The suppliers of the cryogenic components will guarantee spare parts and technical support for a minimum of 30 years. A stock of spares will be purchased for any critical components that might become obsolete during the expected life of the array.

Any components requiring periodic maintenance on the antenna will have a detailed service procedure, and the ease of serviceability will be considered during the design phase. For example, the dual-sleeve concept aims to simplify the cold head swap on the antenna.

4.8 Manufacturability

The complete cryogenic subsystem is composed of COTS or modified off-the-shelf (MOTS) components. The vendors should have no problem meeting the production schedule shown in Table 19.

Production Year	Qty of Compressors	Qty of Cryocoolers
2028	10	20
2029	20	40
2030	30	60
2031	40	80
2032	40	80
2033	40	80
2034	40	80
2035	40	80
2036	20	40
Total	280	560

Table 19: Cryogenic subsystem production schedule.

4.9 Safety Analysis

4.9.1 Personnel Safety

The cryogenic subsystem must address the following personnel safety concerns:

- **High voltage hazards:** The compressor, cryocooler, and pressure regulation module use AC voltage 120VAC and higher. Standard protection measures shall apply no exposed terminals, circuit breakers,



Title: Cryogenic Subsystem Design Description	Author: D. Urbain	Date: 2023-09-14
NRAO Doc. #: 020.30.10.00.00-0007-DSN		Version: C

crush-resistant conduit, warning labels, etc. Only qualified technicians shall have access to the electrical circuitry when under power.

- **High-pressure gas hazards:** The helium circuit is under pressure, 50 psi and above, so helium lines shall be secured to the antenna structure or placed inside a conduit or a cable tray to avoid personnel injury in case of uncontrolled pressure release that could cause sudden movement of the line.
- **Asphyxia:** A sudden, large helium leak could displace the oxygen in a closed space and endanger personnel. An oxygen monitor shall be located in the risk areas to warn technical staff of the danger.
- **Avoid injury from burns:** During operation, some surfaces inside the compressor become hot, so it will be necessary to allow the compressor to cool for half an hour before removing the cover for maintenance.
- **Low temperature:** Cold surfaces must be warmed to ambient temperature before exposure to the atmosphere to avoid ice formation and cold burn.

4.9.2 Hardware Safety

Specific actions performed in the wrong sequence could damage equipment and even create safety hazards for personnel.

- **Venting a cryostat while it is at cryogenic temperature:** If the solenoid valve of a cold cryostat opens, the air rushing in will freeze on the cold surfaces, filling the inside with ice and condensation. This could damage some of the active components and present a safety hazard. Moisture could be trapped between MLI layers, requiring a much longer pump-down time or baking. As the system warms up, the contaminant will evaporate rapidly, increasing the pressure, which could build up and break one of the vacuum windows if the pressure relief valve fails to open quickly enough.
- **Running cold heads when the compressor is OFF:** If the cold head runs without helium circulation, the motor could get hot, and the wire insulation could melt and short-circuit wires in the motor assembly. The displacer, seals, and other mechanical parts could get hot and wear prematurely.
- **Starting the vacuum pump when the temperature is below the recommended operating temperature:** Cold temperatures could cause the pump to fail to start (over-current triggering the breaker). The low viscosity of the oil could present too much resistance for the vanes to move. In the case of the dry vacuum pump, the tip seals might be too stiff and compromise the performance.
- **Starting the compressor when the temperature is below the recommended operating temperature:** Oil viscosity will compromise its ability to circulate through the compressor; the Scroll capsule could overheat, and the compressor could shut down.
- **Running the vacuum pump at high pressure for an extended period:** The pump might get hot, and some oil might escape, carried by the large gas flow.
- **Safety interlock:** Safety interlocks should be implemented to prevent hardware damage in the event of communication problems with the central computer. When practical, hardware design is preferable.

4.10 Technology Readiness Assessment



Title: Cryogenic Subsystem Design Description	Author: D. Urbain	Date: 2023-09-14
NRAO Doc. #: 020.30.10.00.00-0007-DSN		Version: C

4.10.1 Helium Compressor

4.10.1.1 Fixed Frequency Configuration

The fixed-frequency compressor option is only considered for the Oxford Cryosystems system. Their compressors (air-cooled and liquid-cooled) use small Hitachi 2.5HP scroll capsules that should have just enough flow capacity to drive two 4/20 cryocoolers. The estimated 3.6 kW power consumption is well below the 5.42 kW requirement and within the lower range of what can be achieved with a variable-frequency drive on a larger compressor.

4.10.1.2 Variable Frequency Configuration

4.10.1.2.1 Indoor

- Sumitomo

A prototype FA-40 compressor with commercial VFD was purchased two years ago and is being evaluated; the liquid-cooled version should offer the same performance.

- Oxford Cryosystems (OCS)

OCS commercializes a small liquid-cooled compressor that could be retrofitted with a larger scroll capsule rated for VFD operation.

4.10.1.2.2 Outdoor

- Sumitomo

To meet the environmental requirements of an outdoor location, the reference design adopted the proven outdoor enclosure and oil management of the Sumitomo FA-70 and substituted the smaller FA-40 capsule.

- Oxford Cryosystems

OCS could retrofit the outdoor compressor developed for the SKA project with a larger capsule and add heaters to the Scroll capsule to cover the extended temperature range.

4.10.1.3 Start Up at Low Ambient Temperature

To extend the temperature range of the liquid-cooled compressor below 5°C, an oil heating element will have to be added to the standard compressor unless the antenna environmental control is responsible for maintaining the temperature inside the turn-head above 5°C.

4.10.2 Cryocooler

To optimize performance, the cryocooler must be able to operate at variable frequency. Reducing displacer speed will prolong the interval between maintenance and reduce the flow requirement, allowing the compressor to be used at lower power.

4.10.2.1 Trillium 350CS



Title: Cryogenic Subsystem Design Description	Author: D. Urbain	Date: 2023-09-14
NRAO Doc. #: 020.30.10.00.00-0007-DSN		Version: C

NRAO has developed a prototype VFD for the Trillium cryocooler. It is under evaluation in the laboratory and should be deployed later on the VLA Antenna 14.

4.10.2.2 Oxford Cryosystems

The 4/20 cryocooler would be a new model specific to ngVLA; the variable-speed operation is already available across the range of cryocoolers offered by Oxford Cryosystems. The 4/20 would be a medium-size cryocooler between the smaller 2/9 and larger 6/30 already in their catalog. The development should be straightforward and low-risk from an engineering perspective.

The 6/30 model has been in operation for years and was selected by SKA to cool their multiband cryostat.

4.10.2.3 Sumitomo CH-204SFF

Sumitomo does not currently offer a cryocooler with adjustable speed, but the work done on the Trillium cryocooler could be used to design a new VFD for the CH-204SFF. Both cryocoolers use AC synchronous motors, but the Trillium requires two waveforms at 90°, whereas the Sumitomo needs three at 120°.

4.10.3 Helium Pressure Regulation Module

A prototype was built for the VLA and installed on Antenna 14 in 2021. It has demonstrated the effectiveness of the concept in maintaining the pressure of the three compressor circuits connected. The prototype uses an off-the-shelf controller that will be replaced by a custom driver integrated with the M505 utility module and the compressor M&C in the EMI/RFI enclosure.

4.10.4 Dual Sleeve

The French company Callisto SA currently offers a version of the dual-sleeve concept in an open version for the Sumitomo CH-204SFF. A closed version that preserves the cryostat vacuum during maintenance is preferred and could be developed. Before the concept is adopted, the impacts on thermal loading, thermal transfer, and cryostat design must be fully understood. The thermal load increase might trigger a power consumption increase that has to be estimated.

The proposed price for production is also high, so more work needs to be done by Callisto SA and NRAO to bring the manufacturing cost down to a more reasonable level. While the dual-sleeve design is specific to a cryocooler, studying the concept with the Sumitomo cold head early on could save a lot of time and should be considered if allowed by the budget.

4.11 Down-Selects

The variable speeds GM cryocoolers have been chosen as the primary option for the project. A request for a proposal was sent out in December 2022 to a broad selection of manufacturers. Due to limited funding, only one supplier could be selected. Oxford Cryosystems (OCS) was chosen to develop a complete ngVLA cryogenic subsystem prototype, including a variable speeds liquid-cooled compressor and two variable speeds cryocoolers.

Because OCS already had a variable speeds cryocooler with the required cooling capacity, the 6/30, the development focused on the liquid-cooled variable speed compressor. The prototype equipment is scheduled to ship in September 2023.



Title: Cryogenic Subsystem Design Description	Author: D. Urbain	Date: 2023-09-14
NRAO Doc. #: 020.30.10.00.00-0007-DSN		Version: C

Based on our VLA experience, we chose the Alcatel Adixen 2021SD rotary vane pump for the prototype antenna and selected a model that runs on a 480VAC 3-phase power.

5 Appendix A: Trade Studies

The trade study between the GM cryocooler and the Thermo Acoustic Stirling Cryocooler (TASC) can be found in [AD02]. A panel of internal reviewers looked at both cryocooler options [AD03] and recommended pursuing the development of the GM cryocooler through the design phase, all the way to the PDR. However, NRAO and RIX Industries will continue to work on the dual-stage TASC as an enhancement/development project to explore the full potential of this technology for the field of radio astronomy and as a possible alternative solution for the project.

6 Appendix B: Abbreviations and Acronyms

Acronym	Description
AC	Alternating Current
AD	Applicable Document
COTS	Commercial Off-The-Shelf
DBE	Digital Back End
DC	Direct Current
DTS	Data Transmission System
EIRP	Effective Isotropic Radiated Power
GM	Gifford-McMahon
LNA	Low Noise Amplifier
LRU	Line Replaceable Unit
MLI	Multi-Layer Insulation
MOTS	Modified Off-The-Shelf
ngVLA	Next Generation VLA
OCS	Oxford Cryosystems
PDR	Preliminary Design Review
RD	Reference Document
RR	Remove and Replace
RC network	Resistor Capacitor network
SRU	Shop Replaceable
TASC	ThermoAcoustic Stirling Cryocooler
VLA	Jansky Very Large Array











020.30.10.00.00-0007-DSN- Cryogenic Subsystem Design Description

Final Audit Report

2023-09-19

Created:	2023-09-14
By:	Alicia Kuhn (akuhn@nrao.edu)
Status:	Signed
Transaction ID:	CBJCHBCAABAAHght0RKQota2D0T85qXubZUvZ14iXrMB

"020.30.10.00.00-0007-DSN- Cryogenic Subsystem Design Description" History

-  Document created by Alicia Kuhn (akuhn@nrao.edu)
2023-09-14 - 6:24:50 PM GMT
-  Document emailed to plopez@nrao.edu for signature
2023-09-14 - 6:48:28 PM GMT
-  Email viewed by plopez@nrao.edu
2023-09-14 - 7:01:51 PM GMT
-  Signer plopez@nrao.edu entered name at signing as Phillip Lopez
2023-09-14 - 8:25:18 PM GMT
-  Document e-signed by Phillip Lopez (plopez@nrao.edu)
Signature Date: 2023-09-14 - 8:25:20 PM GMT - Time Source: server
-  Document emailed to pkotze@nrao.edu for signature
2023-09-14 - 8:25:22 PM GMT
-  Email viewed by pkotze@nrao.edu
2023-09-14 - 9:34:40 PM GMT
-  Signer pkotze@nrao.edu entered name at signing as P.P.A.Kotzé
2023-09-14 - 9:35:09 PM GMT
-  Document e-signed by P.P.A.Kotzé (pkotze@nrao.edu)
Signature Date: 2023-09-14 - 9:35:11 PM GMT - Time Source: server
-  Document emailed to Rob Selina (rselina@nrao.edu) for signature
2023-09-14 - 9:35:13 PM GMT



 Email viewed by Rob Selina (rselina@nrao.edu)

2023-09-14 - 9:36:07 PM GMT

 Signer Rob Selina (rselina@nrao.edu) entered name at signing as RJS

2023-09-15 - 3:08:21 PM GMT

 Document e-signed by RJS (rselina@nrao.edu)

Signature Date: 2023-09-15 - 3:08:23 PM GMT - Time Source: server

 Document emailed to whojnows@nrao.edu for signature

2023-09-15 - 3:08:25 PM GMT

 Email viewed by whojnows@nrao.edu

2023-09-19 - 4:04:42 PM GMT

 Signer whojnows@nrao.edu entered name at signing as William Hojnowski

2023-09-19 - 4:06:54 PM GMT

 Document e-signed by William Hojnowski (whojnows@nrao.edu)

Signature Date: 2023-09-19 - 4:06:56 PM GMT - Time Source: server

 Agreement completed.

2023-09-19 - 4:06:56 PM GMT

