



Title: System Conceptual Design Description	Owner: Selina	Date: 2022-06-06
NRAO Doc. #: 020.10.20.00.00-0005-REP		Version: A



System Conceptual Design Description

020.10.20.00.00-0005-REP
 Status: **RELEASED**

PREPARED BY:
R. Selina, E. Murphy, T. Kusel, A. Beasley, J. Allison, R. Amestica, M. Archuleta, S. Bhatnagar, P. Brandt, B. Butler, C. Carilli, J. Carilli, N. Denman, D. Dunbar, S. Durand, B. DuVerneay, G. Cole, P. Demorest, A. Erickson, W. Esterhuyse, E. Ford, D. Gerrard, W. Grammer, C. Hales, R. Hiriart, T. Hunter, J. Jackson, J. Kern, W. Koski, C. Langley, P. Lopez, J. Mangum, B. Mason, M. McKinnon, J. Muehlberg, M. Morgan, O. Ojeda, M. Pokorny, U. Rao, M. Romero, R. Rosen, V. Rosero, B. Sadowski, W. Shillue, T.K. Sridharan, S. Srikanth, S. Sturgis, A. Symmes, K. Swift, D. Urbain., C. Walker, J. Wrobel.

APPROVALS	ORGANIZATION	SIGNATURE
R. Selina, Project Engineer	ngVLA, NRAO	
T. Kusel, Systems Engineer	ngVLA, NRAO	 Thomas Kusel (Jun 6, 2022 13:32 EDT)
E. Murphy, Project Scientist	ngVLA, NRAO	 E. J. Murphy (Jun 6, 2022 13:33 EDT)
W. Esterhuyse, Telescope Project Manager	ngVLA, NRAO	

RELEASED BY	ORGANIZATION	SIGNATURE
W. Esterhuyse, Telescope Project Manager	ngVLA, NRAO	



Title: System Conceptual Design Description	Owner: Selina	Date: 2022-06-06
NRAO Doc. #: 020.10.20.00.00-0005-REP		Version: A

Change Record

Version	Date	Author	Affected Section(s)	Reason
01	2021-06-25	Selina	All	First draft of outline, based on Reference Design report rev B.
02	2021-08-28	Selina	6, 7.1	Updates to summary; configuration to rev D.
03	2021-09-02	Selina	1 – 5	Synchronized with latest Science Requirements, System Requirements, etc.
04	2021-10-14	Selina	1, 7, 8, 9	Continued update to synchronize subsystem sections. Moved WVR to be under Antenna Electronics. Removed cost sections.
05	2022-01-04	Selina	1 – 7.2	Completed initial edit of system sections. Stills synchronizing subsystem sections
06	2022-05-25	Selina	All	Continued update of subsystem sections. Updated civil and infrastructure, CSP, LORT, CSW, etc. Distributed for team review.
07	2022-06-05	Selina	All	Updated to resolve RIDs from team review.
A	2022-06-06	Selina	Cover	Updated for release for System CDR.



Title: System Conceptual Design Description	Owner: Selina	Date: 2022-06-06
NRAO Doc. #: 020.10.20.00.00-0005-REP		Version: A

Table of Contents

1	Introduction.....	5
1.1	<i>Purpose of this Document.....</i>	5
1.2	<i>Applicable Documents.....</i>	6
1.3	<i>Reference Documents.....</i>	7
2	Science Requirements.....	11
3	System Requirements	13
4	Lifecycle Concepts.....	16
4.1	<i>Operations Concept.....</i>	16
4.2	<i>Assembly, Integration, and Verification (AIV) Concept.....</i>	16
4.3	<i>Commissioning and Science Validation (CSV) Concept.....</i>	17
5	System Architecture	18
6	System Design Overview	19
6.1	<i>Overview.....</i>	19
6.2	<i>Array Performance.....</i>	20
6.3	<i>New Parameter Space.....</i>	23
6.4	<i>Observing Modes & Data Products</i>	25
6.5	<i>Site Selection.....</i>	26
6.5.1	<i>RFI</i>	26
6.5.2	<i>Atmospheric Phase Stability</i>	26
6.5.3	<i>Atmospheric Opacity.....</i>	27
6.5.4	<i>Final Site Selection.....</i>	28
7	Conceptual Design.....	29
7.1	<i>Array Configuration.....</i>	29
7.2	<i>Array Calibration</i>	33
7.3	<i>Antennas.....</i>	34
7.3.1	<i>18m Antennas.....</i>	34
7.3.2	<i>6m Short Baseline Array Antennas</i>	38
7.4	<i>Antenna Electronics.....</i>	39
7.4.1	<i>Front End.....</i>	39
7.4.2	<i>Cryogenic System.....</i>	41
7.4.3	<i>Integrated Down Converters & Digitizers.....</i>	42
7.4.4	<i>Digital Back End (DBE).....</i>	45
7.4.5	<i>Water Vapor Radiometer System.....</i>	47
7.4.6	<i>DC Power Supply System.....</i>	48
7.4.7	<i>Bins, Modules and Racks.....</i>	49
7.4.8	<i>Environmental Control.....</i>	52
7.5	<i>Local Oscillator Reference and Timing.....</i>	53
7.5.1	<i>LO Reference & Timing Generation (RTG).....</i>	54
7.5.2	<i>LO Reference & Timing Distribution (RTD)</i>	54
7.5.3	<i>Antenna Time and Frequency (ATF).....</i>	56
7.6	<i>Central Signal Processor.....</i>	57
7.7	<i>Data Transmission System.....</i>	60
7.8	<i>Computing and Software System.....</i>	62
7.8.1	<i>Software System Structure.....</i>	63
7.8.2	<i>Monitor and Control System.....</i>	66
7.8.3	<i>Offline Subsystem Sizing.....</i>	68



Title: System Conceptual Design Description	Owner: Selina	Date: 2022-06-06
NRAO Doc. #: 020.10.20.00.00-0005-REP		Version: A

7.9 Buildings and Array Infrastructure..... 71

8 Appendix..... 74

8.1 Acronyms and Abbreviations..... 74



Title: System Conceptual Design Description	Owner: Selina	Date: 2022-06-06
NRAO Doc. #: 020.10.20.00.00-0005-REP		Version: A

I Introduction

The Next Generation Very Large Array (ngVLA) is a project of the National Radio Astronomy Observatory (NRAO) to design and build an astronomical observatory that will operate at centimeter to millimeter wavelengths (25 to 0.26 centimeters, corresponding to a frequency range extending from 1.2 GHz to 116 GHz).

The ngVLA will replace both the Very Large Array (VLA) and Very Long Baseline Array (VLBA). It will be a synthesis radio telescope composed of approximately 244 reflector antennas each of 18 meters diameter, and 19 reflector antennas each of 6 meters diameter, operating in a phased or interferometric mode. The array will be centered at the Very Large Array site on the Plains of San Agustin, New Mexico, with mid-baseline and long-baseline antennas located across North America.

The facility will operate as a proposal-driven instrument with Principal Investigator (PI)-led proposals determining the science program. Data will generally be delivered to PIs as pipeline produced and calibrated high-level data products (typically image cubes). Data and quality assured data products will be available through an Observatory science archive. Data exploration tools will allow users to analyze the data directly from the archive.

1.1 Purpose of this Document

This document presents a summary of the system-level design, the overall system architecture, and supporting concepts for major system elements such as the antenna, receiving electronics, and central signal processor. This document is the highest-level design description in the conceptual design package. Supporting pieces of the conceptual design technical baseline are listed here to give a full overview of the proposed design while also identifying key supporting design materials relevant to understanding specific system elements. The system-level trades that have informed the design are summarized in AD55. The programmatic approach to delivering the proposed design and the associated management plans are summarized in AD51.

The ngVLA project is presently in the early design stage. Approval of the conceptual design as a technical baseline will confirm that the team has an understanding of the requirements for the system, a supporting system architecture and high-level design, and the driving sub-system requirements. Individual sub-systems vary in their degree of development – major hardware systems such as the antenna and signal chain electronics are presently at a higher level of design maturity, while data processing, infrastructure and supporting services are less defined. Conceptual design down selects for these major hardware systems are reflected in this conceptual design report. Additional subsystem conceptual design down selects will build upon these decisions, providing an end-to-end design baseline. The detailed system architecture and interfaces between all sub-systems will be baselined by the system preliminary design review, providing the full degree of required system-level definition for parallel development of the sub-systems that comprise the system architecture. The design described in this report and applicable documents will form the technical baseline for developing the ngVLA preliminary design and supporting programmatic requests to complete the design and proceed to facility construction.



Title: System Conceptual Design Description	Owner: Selina	Date: 2022-06-06
NRAO Doc. #: 020.10.20.00.00-0005-REP		Version: A

1.2 Applicable Documents

The following documents are applicable to this design report and are incorporated by reference. In the event of conflict, the applicable document supersedes the content of this report.

Ref. No.	Document Title	Rev/Doc. No.
AD01	ngVLA Science Requirements	020.10.15.05.00-0001-REQ
AD02	Stakeholder Requirements	020.10.15.01.00-0001-REQ
AD03	System Requirements	020.10.15.10.00-0003-REQ
AD04	System Environmental Specification	020.10.15.10.00-0001-SPE
AD05	System EMC and RFI Mitigation Requirements	020.10.15.10.00-0002-REQ
AD06	System Security Specification	020.80.00.00.00-0003-REQ
AD07	LI Safety Requirements	020.80.00.00.00-0001-REQ
AD08	Operations Concept	020.10.05.00.00-0002-PLA
AD09	Preliminary System Architecture Description	020.10.20.00.00-0002-REP
AD10	Antenna Electronics Block Diagrams	020.30.00.00.00-0005-BLK
AD11	Antenna Coordinate Systems	020.10.30.00.00-0001-SPE
AD12	Product Breakdown Structure	020.10.10.05.00-0001-LIS
AD13	Array Configuration: Technical Requirements	020.23.00.00.00-0001-REQ
AD14	Array Configuration: Conceptual Design Description	020.23.00.00.00-0002-DSN
AD15	Calibration Requirements	020.22.00.00.00-0001-REQ
AD16	18-meter Antenna Optics Design	EA-NGV-DR-05
AD17	Antenna Technical Requirements	020.25.00.00.00-0001-REQ
AD18	18-meter Antenna Optics Definition	020.25.01.00.00-0006-DSN
AD19	ngVLA Antenna: Design Report	1021006-REP-21-00000-001
AD20	Short Baseline Array Antenna: Technical Requirements	020.47.05.00.00-0001-REQ
AD21	Short Baseline Array Antenna: Conceptual Design	102-0000-001-CDD-002
AD22	Front End Technical Requirements	020.30.05.00.00-0003-REQ
AD23	Front End Conceptual Design Description	020.30.05.00.00-0006-DSN
AD24	Cryogenic System Technical Requirements	020.30.10.00.00-0001-REQ
AD25	Cryogenic System Design Description	020.30.10.00.00-0007-DSN
AD26	Integrated Receivers & Digitizer: Technical Requirements	020.30.15.00.00-0001-REQ
AD27	Integrated Receivers & Digitizer: Conceptual Design	020.30.15.00.00-0002-DSN
AD28	ngVLA Receiver Cascaded Analysis Tool	020.30.05.00.00-0004-GEN
AD30	DC Power Supply System: Technical Requirements	020.30.50.00.00-0001-REQ
AD31	DC Power Supply System: Conceptual Design	020.30.50.00.00-0002-DSN
AD32	Antenna Time and Frequency Requirements	020.30.35.00.00-0004-REQ
AD33	Bins, Modules & Racks: Conceptual Design	020.30.55.00.00-0002-DSN
AD34	Environmental Control: Technical Requirements	020.30.60.00.00-0001-REQ
AD35	Environmental Control: Conceptual Design	020.30.60.00.00-0002-DSN
AD36	LO Reference and Timing: Technical Requirements	020.35.00.00.00-0003-REQ
AD37	LO Reference and Timing: Conceptual Design	020.35.00.00.00-0002-DSN
AD38	Central Signal Processor: Technical Requirements	020.40.00.00.00-0001-REQ
AD39	Central Signal Processor: Conceptual Design	020.40.00.00.00-0002-DSN
AD40	Water Vapor Radiometer System: Technical Requirements	020.45.00.00.00-0001-REQ
AD41	Water Vapor Radiometer System: Conceptual Design	020.45.00.00.00-0002-DSN
AD42	Computing & Software Systems: Technical Requirements	020.50.00.00.01-0001-REQ
AD44	Monitor & Control System: Design Concept	020.50.25.00.00-0002-DSN



Title: System Conceptual Design Description	Owner: Selina	Date: 2022-06-06
NRAO Doc. #: 020.10.20.00.00-0005-REP		Version: A

Ref. No.	Document Title	Rev/Doc. No.
AD46	Monitor & Control System: Hardware Interface Layer Technical Requirements	020.30.45.00.00-0002-REQ
AD47	Civil and Infrastructure Subsystems: Requirements Specification	020.60.00.00.00-0003-REQ
AD48	Civil and Infrastructure Subsystems: Design Description	020.60.00.00.00-0004-DSN
AD49	The Total Power Array Concept of Operations & System Level Requirements	020.27.00.00.00-0001-REQ
AD50	ngVLA N ² Matrix	020.10.40.00.00-0001-DWG
AD51	Project Execution Plan	020.05.00.00.00-0006-PLA
AD52	Assembly, Integration, & Verification (AIV) Concept	020.10.05.00.00-0006-PLA
AD53	Commissioning & Science Validation (CSV) Concept	020.10.05.00.00-0006-PLA
AD54	Status Levels for New ngVLA PI Observing Modes	020.10.05.05.00-0004-PLA
AD55	System Concept Options & Trade-Offs	020.10.25.00.00-0005-REP
AD56	Reference Observing Program	020.10.15.05.10-0001-REP
AD57	Envelope Observing Program	020.10.15.05.10-0002-REP
AD58	Observing Mode Framework	020.10.05.05.00-0005-PLA
AD59	Observing Mode Calibration Strategy	020.10.05.05.00-0006-PLA
AD60	Calibration Plan	020.10.25.00-0006-PLN

1.3 Reference Documents

The following documents provide additional material or supporting context.

Ref. No.	Document Title	Rev/Doc. No.
RD01	Summary of the Science Use Case Analysis	ngVLA Memo No. 18
RD02	Key Science Goals for the ngVLA	ngVLA Memo No. 19
RD03	ngVLA Science Book	Astronomical Society of the Pacific, Monograph Vol. 7, 2018
RD04	Interferometry & Synthesis in Radio Astronomy	Thomson, Moran, Swenson, 2nd Edition
RD05	Science Ready Data Products System Concept	530-SRDP-014-MGMT
RD06	Science Ready Data Products System Architecture	(In Prep.)
RD07	ngVLA Cost Model Memo	020.05.15.00.00-0004-REP
RD08	ngVLA Cost Model Spreadsheet	020.05.15.00.00-0005-REP
RD09	Reference Design Development & Performance Estimates	ngVLA Memo No. 17
RD10	More on Synthesized Beams and Sensitivity	ngVLA Memo No. 16
RD11	Possible Configurations for the ngVLA	ngVLA Memo No. 03
RD12	SKA Design Studies Technical Memo 107	Lal, D., Lobanov, A., Jimenez-Monferrer, S., SKA Design Studies Technical Memo 107, 2011
RD13	Fast Switching Phase Calibration at 3mm at the VLA site	ngVLA Memo No. 1
RD14	Calibration Strategies for the Next Generation VLA	ngVLA Memo No. 2
RD15	An RFI Survey at the Site of the Long Wavelength Demonstration Array (LWDA)	Stewart, K. P. et al., BAAS 37, 1389, 2005



Title: System Conceptual Design Description	Owner: Selina	Date: 2022-06-06
NRAO Doc. #: 020.10.20.00.00-0005-REP		Version: A

Ref. No.	Document Title	Rev/Doc. No.
RD16	The ngVLA Short Baseline Array	ngVLA Memo No. 43
RD17	Getting the Big Picture: Design Considerations for a ngVLA Short Spacing Array	Mason, B. et al., American Astronomical Soc., 2018
RD18	SKA-I System Baseline Design	SKA Doc No. SKA-TEL-SKO-DD-001
RD19	Imaging Capabilities: Protoplanetary Disks Comparison	ngVLA Memo No. 11
RD20	The Strength of the Core	ngVLA Memo No. 12
RD21	Short Spacing Considerations for the ngVLA	ngVLA Memo No. 14
RD22	Resolution & Sensitivity of ngVLA-RevB	ngVLA Memo No. 47
RD23	The Concept of a Reference Array for the ngVLA	ngVLA Memo No. 4
RD24	Considerations for a Water Vapor Radiometer System	ngVLA Memo No. 10
RD25	Polarization Calibration with Linearly Polarized Feeds	ngVLA Memo No. 45
RD26	Technical Study: Offset Gregorian Antenna	ngVLA Memo No. 26
RD27	Exploration of Suitable Mounts for a 15m Offset Antenna Next Generation Very Large Array NRC 15m Mount	ngVLA Memo No. 25
RD28	Various Suitable Mounts for an 18m Antenna	ngVLA Memo No. 27
RD29	Advanced Cryocoolers for the Next Generation VLA	ngVLA Memo No. 24
RD30	Short Baseline Array: Reference Design Description	ngVLA Memo No. 43
RD31	Software Requirements for RFI Management,	ngVLA Computing Memo #3
RD32	High Performance Gridding	ngVLA Computing Memo #5
RD33	Size-of-Computing Estimates for ngVLA Synthesis Imaging	ngVLA Computing Memo #4
RD34	Legacy Science Program	020.10.05.00.00-0004-PLA
RD35	ngVLA Front End Thermal Study Analysis Report	Calisto REP/1406/4366
RD36	An Integrated Receiver Concept for the ngVLA	ngVLA Memo No. 29
RD37	TM's View of the Mid.CBF Frequency Slice Approach.	Rupen, M. 2017
RD38	Precipitable Water at the VLA: 1990–1998	VLA Scientific Memo 176
RD39	Phase Fluctuations at the VLA Derived from One Year of Site Testing	VLA Test Memo 222
RD40	An RFI Survey at the Site of the Long Wavelength Demonstration Array (LWDA)	Stewart, K. P. et al. BAAS 37, 1389, 2005
RD41	A Preliminary Survey of Radio-Frequency Interference Over the US in Aqua AMSR-E Data	Li et al. IEEE TGRS, 42, 380, 2004
RD42	Subarray Processing for Projection-based RFI Mitigation in Radio Astronomical Interferometers	Burnett, M et al. AJ, 155, id.146, 2018
RD43	The Very Large Array	Thomson, A. R. et al. ApJSS, 44, 151, 1980
RD44	Snapshot UV Coverage of the ngVLA: An Alternate Configuration	ngVLA Memo No. 49



Title: System Conceptual Design Description	Owner: Selina	Date: 2022-06-06
NRAO Doc. #: 020.10.20.00.00-0005-REP		Version: A

Ref. No.	Document Title	Rev/Doc. No.
RD45	A Dedicated Pulsar Timing Array Telescope	ngVLA Memo No. 34
RD46	Next Generation Low Band Observatory: A Community Study Exploring Low Frequency Options for ngVLA	ngVLA Memo No. 20
RD47	Taperability Study for the ngVLA and Performance Estimates	ngVLA Memo No. 55
RD48	System-level Cost Comparison of Offset and Symmetric Optics	ngVLA Antenna Memo No. 1
RD49	System-level Evaluation of Aperture Size	ngVLA Antenna Memo No. 2
RD50	Configuration: Reference Design Rev D Description	ngVLA Memo No. 92
RD51	Snapshot UV Coverage of the ngVLA: An Alternate Configuration	ngVLA Memo No. 49
RD52	Short Spacing Issues for Mapping Extended Emission: Milky Way Case Study	ngVLA Memo No. 54
RD53	Taperability Study for the ngVLA and Performance Estimates	ngVLA Memo No. 55
RD54	Sculpting of the Synthesized Beam and Image Fidelity Study of KSG 1: Imaging of Protoplanetary Disks	ngVLA Memo No. 65
RD55	Demonstration & Analysis of ngVLA core + Short Baseline Array Extended Structure Imaging v2	ngVLA Memo No. 67
RD56	A Study of ngVLA Subarray Efficiency: Plains + Fractions of the Core	ngVLA Memo No. 72
RD57	Subarray Selection for the Reference Observing Program	ngVLA Memo No. 76
RD58	The NGVLA Long Baseline Array: Configuration Suggestions	ngVLA Memo No. 84
RD59	Comparison of Alternative Configurations for the ngVLA Plains Subarray Addendum	ngVLA Memo No. 85
RD60	Imaging Evaluation of Two Mid Configurations	ngVLA Memo No. 86
RD61	Image Fidelity Study of KSG 3 (NGA8): Imaging Molecular Gas in Nearby Galaxies Addendum	ngVLA Memo No. 89
RD62	Image Dynamic Range Limits Arising From Visibility Errors	ngVLA Memo No. 60
RD63	Temporal and Spatial Tropospheric Phase Fluctuations at the VLA (and Beyond) and Implications for Phase Calibration	ngVLA Memo No. 61
RD64	Preliminary ngVLA Observing Band Availability Estimate	ngVLA Memo No. 73
RD65	Antenna Optical Design Alternatives	ngVLA Antenna Memo No. 3
RD66	Efficiency Loss and Pointing Offsets Due to Feed Offsets on the ngVLA Reference Design Antenna	ngVLA Antenna Memo No. 8
RD67	Practical Limits to Axis Offsets	ngVLA Antenna Memo No. 9
RD68	Statement of Work: Final Design and Prototype of the ngVLA 18m Antenna	020.05.55.10.00-0005-SOW
RD69	Long Haul Fiber Workgroup Preliminary Report	020.60.00.00.00-0002-REP



Title: System Conceptual Design Description	Owner: Selina	Date: 2022-06-06
NRAO Doc. #: 020.10.20.00.00-0005-REP		Version: A

Ref. No.	Document Title	Rev/Doc. No.
RD70	Advanced Stirling Pulse Tube Cryocooler and Variable Speed Gifford McMahon Cryocooler Trade Study	ngVLA Electronics Memo No. 3
RD71	Thermoacoustic Stirling Cryocooler and Variable Speed Gifford McMahon Cryocooler Trade Study No. 2	ngVLA Electronics Memo No. 12
RD72	Cryogenics Development Plan	020.30.10.00.00-0006-PLA
RD73	Cryogenics Concept Selection	020.30.10.00.00-0009-REP
RD74	Downconversion and Digitization Methodology for the ngVLA	ngVLA Electronics Memo No. 1
RD75	An Integrated Receiver Concept for the ngVLA	ngVLA Memo No. 29
RD76	Headroom, Dynamic Range, and Quantization Considerations	ngVLA Electronics Memo No. 8
RD77	Antenna LO Trade Study	020.30.35.00.00-0003-REP
RD78	Trident 2.1 Concept: Updates to the CSP Reference Design	ngVLA Electronics Memo No. 5
RD79	Baseline HPG Runtime Performance for Imaging	ngVLA Computing Memo #7
RD80	Designing an ngVLA Dynamic Scheduler	ngVLA Computing Memo #6
RD81	Evaluation of the Revision D Array Configuration for Stellar Imaging	ngVLA Memo No. 95
RD82	Validity of the single-processor approach to achieve large scale computing capabilities	Amdahl, G.M. (1967) AFIPS Joint Spring Conference Proceedings 30 (Atlantic City, NJ, Apr. 18–20), AFIPS Press, Reston VA, pp 483–485.
RD83	Reevaluating Amdahl's law	Gustafson (May 1988) Commun ACM, 31(5):532–533. DOI = 10.1145/42411.42415
RD84	Baseline-dependent averaging in radio interferometry	Wijnholds, S. J. (2018) MNRAS, Volume 476, Issue 2, May 2018, Pages 2029–2039, https://doi.org/10.1093/mnras/sty360



Title: System Conceptual Design Description	Owner: Selina	Date: 2022-06-06
NRAO Doc. #: 020.10.20.00.00-0005-REP		Version: A

2 Science Requirements

The ngVLA Science Requirements appear in [AD01], Science Requirements, 020.10.15.05.00-0001-REQ. Additional supporting material that led to definition of these science requirements appears in [RD01–03]:

- Summary of the Science Use Case Analysis, ngVLA Memo No. 18
- Key Science Goals for the ngVLA, ngVLA Memo No. 19
- ngVLA Science Book, ASP Monograph Vol. 7, 2018

To develop the facility science case, the project solicited science use cases from the user community. Eighty science use cases compiled from more than 200 authors were submitted to the Science Working Groups (SWGs). The Science Advisory Council (SAC) assessed the use cases based on scientific merit, degree of development, feasibility, and other relevant metrics. The five Key Science Goals (KSGs) of the ngVLA emerged from this ranking process [RD02]. The KSGs were chosen to satisfy three criteria:

- Each addresses an important, unanswered question in astrophysics that has broad scientific and societal implications.
- Progress in each area is uniquely addressed by the capabilities of the ngVLA.
- Each exhibits key synergies and complementarity with science goals being pursued by existing or planned facilities in the 2025 and beyond time frame.

The Key Science Goals and all other science use cases were parameterized and analyzed [RD01] to determine the ngVLA Science Requirements. While this aspect of the requirements definition is top-down and mission-driven, some judicious adjustment of the requirements was still appropriate. A primary science requirement for the ngVLA is to be flexible enough to support the breadth of scientific investigations that its creative scientist-users will propose over the instrument’s decades-long lifetime. The requirements have therefore been adjusted to provide a balanced, flexible, and coherent complement of capabilities. The requirements that drive the design are encapsulated in [AD01] and summarized below.

Frequency Coverage: The ngVLA should be able to observe in all atmospheric windows between 1.2 and 116 GHz. These frequency limits are bracketed by spectral line emission from HI and CO respectively.

Continuum Sensitivity: A continuum sensitivity of better than 0.07 $\mu\text{Jy}/\text{bm}$ at 30 GHz and 0.5 $\mu\text{Jy}/\text{bm}$ 100 GHz is required for studying protoplanetary disks (KSG1). This requires a combination of large collecting area and wide system bandwidth. Very long baseline (VLB) continuum sensitivity of better than 0.23 $\mu\text{Jy}/\text{bm}$ at 10 GHz is required to detect the electromagnetic counterparts of gravitational wave (GW) events at a distance of 200 Mpc.

Line Sensitivity: A line sensitivity of 30 $\mu\text{Jy}/\text{bm}$ at 1km/s resolution for frequencies between 10 and 50 GHz is simultaneously required to support both astrochemistry studies and deep/blind spectral line surveys. A line sensitivity of 1–750 mK at 5”–0.1” angular resolution and 1–5 km/s spectral resolution between 70 and 116 GHz is required to simultaneously support detailed studies of CO and variations in gas density across the local universe. The spectral line cases push the system design towards quantum-limited noise performance above 10 GHz.

Angular Resolution: A synthesized beam having a FWHM better than 5 mas with uniform weights is required at both 30 and 100 GHz, while meeting the continuum sensitivity targets. VLB angular resolution of 0.7 mas at 10 GHz is required to measure the proper motions of GW events at a distance of 200 Mpc.

Largest Recoverable Scale: Angular scales of $>20'' \times (100 \text{ GHz}/f)$ must be recovered at frequencies $f < 100 \text{ GHz}$. A more stringent desire is accurate flux recovery on arcminute scales at all frequencies. These scales approach the primary beam size of an 18 m dish, so both shorter baselines and a total power capability are necessary to completely fill in the central hole in the (u, v) -plane.



Title: System Conceptual Design Description	Owner: Selina	Date: 2022-06-06
NRAO Doc. #: 020.10.20.00.00-0005-REP		Version: A

Imaging Fidelity: The array shall produce high fidelity imaging (>0.9) over a wide range of scales, spanning from a few arcmin to a few mas. Snapshot performance should yield high fidelity imaging on angular scales $>100\text{mas}$ at 20 GHz for strong sources. These requirements influence the distribution of collecting area and also require the shorter baselines and total power capabilities to ensure correct flux recovery over complex fields.

Surface Brightness Sensitivity: The array shall provide high-surface brightness sensitivity over the full range of angular scales recoverable with the instrument. The line sensitivity requirement of 1–750 mK at 5”–0.1” angular resolution between 70 and 116 GHz leads to a centrally condensed distribution of antennas.

Brightness Dynamic Range: The system brightness dynamic range (for emissive cases) shall be better than 45 dB for deep field studies. This requirement pushes several systematic requirements including antenna pointing, and electronic gain and phase stability.

Survey Speed: The array shall be able to map a ~ 7 square degree region to a depth of $\sim 1 \mu\text{Jy/bm}$ at 2.5 GHz and a 10 square degree region to a depth of $\sim 10 \mu\text{Jy/bm}$ at 28 GHz within a 10-hour epoch to localize transient phenomena identified with other instruments. Holding collecting area and receiver noise constant, this favors smaller apertures.

Beamforming for Pulsar Search, Pulsar Timing, and VLBI: The array shall support no less than ten beams spread over one to ten subarrays that are transmitted, with up to 8 GHz of bandwidth, to a pulsar search engine or pulsar timing engine. The pulsar search and timing engine must be integral to the baseline design. VLBI recording of a single element, or phased array output, shall be supported for at least three beams.

High-Level Data Products: The primary data product delivered to users shall be calibrated images and cubes. Uncalibrated (“raw”) visibilities shall be archived to permit reprocessing. Producing these higher-level data products requires standardization of initial system modes/configurations (e.g., limited tuning options) and repeatability/predictability from the analog system to reduce calibration overheads. These repeatability and stability requirements significantly influence the architecture of the down conversion and digitization subsystems.

In addition to these science requirements, the project has compiled a set of science use cases to inform the design. The Reference Observing Program (ROP) [AD56] focuses on the Key Science Goals and their supporting observations only. This represents a minimum set of observations necessary to fulfill the KSGs and provides a lower bound on system capabilities. The ROP has been used to size the computing resources that must be delivered as part of the system scope and as a mechanism to assess if the system could complete the KSGs in its operational design life, and the fraction of time that may be available for a PI-driven science projects. The ROP also defines the minimum set of standard observing modes that must be delivered as part of the construction project scope to support the KSGs in early operations.

A more representative use case set that encompasses a mix of use cases representative of a notional year of full operations, with a science program that supports the KSGs and includes anticipated observations from an open call for proposals, is captured as the Envelope Observing Program [AD57]. The EOP is used as the primary benchmark to assess the projected performance of the system as it evolves, and the complement of capabilities that will be delivered within the scope of the construction project.

Title: System Conceptual Design Description	Owner: Selina	Date: 2022-06-06
NRAO Doc. #: 020.10.20.00.00-0005-REP		Version: A

3 System Requirements

The ngVLA system requirements and supporting analysis can be found in [AD03–07]. Figure I shows the relationship of the stakeholder (Level-0) and system (Level-I) requirements and context documents within the requirements hierarchy.

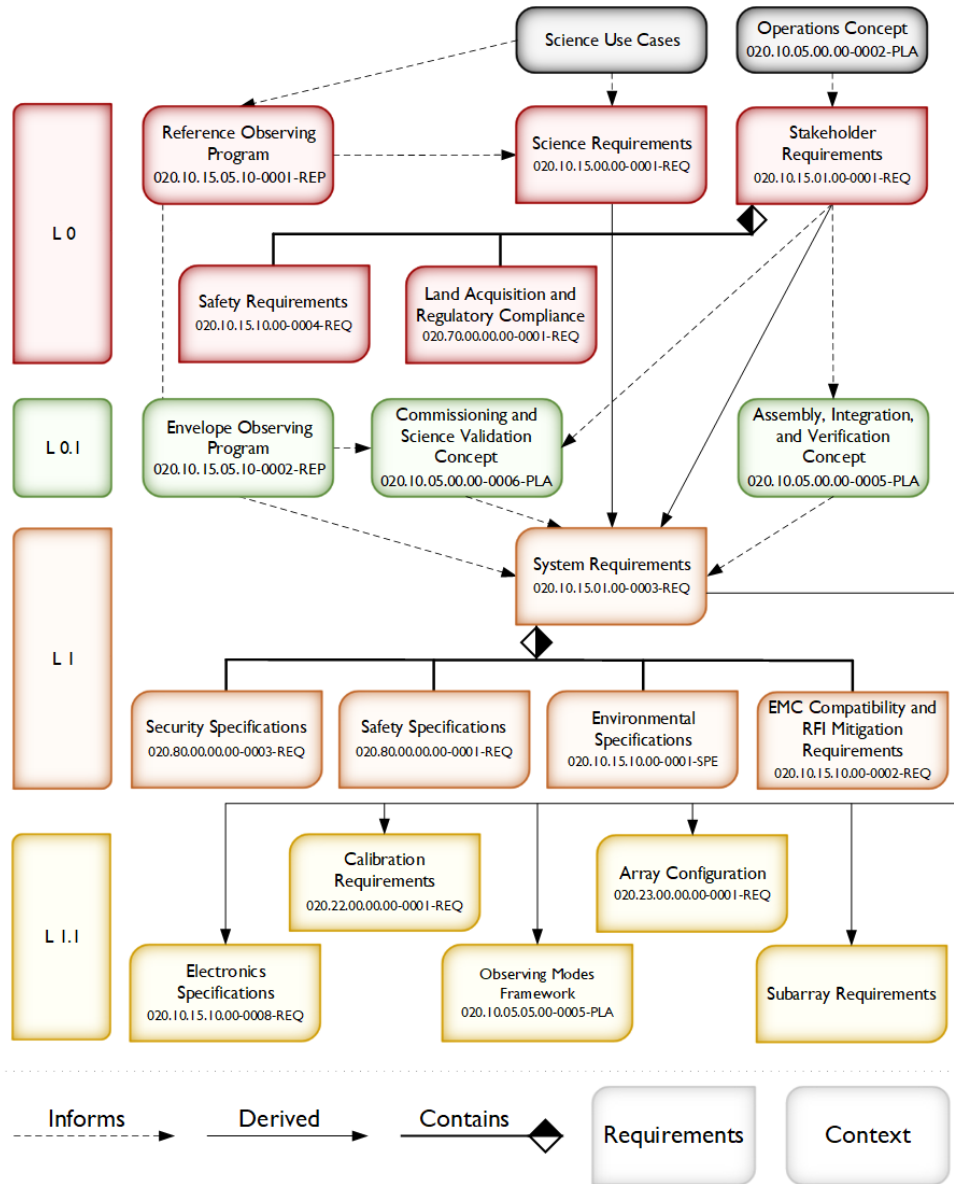

Figure I - Relationship between L0 science requirements, L1 system requirements, and associated system-level specifications. [AD03]

The system requirements [AD03] support the science requirements [AD01] as well as other stakeholder requirements [AD02] elicited through the development of lifecycle concepts and other identified programmatic or regulatory requirements. The traceability of the requirements from the science and stakeholder level through to the system and sub-system level is managed in a common requirements and architecture model implemented in the Systems Modeling Language, SysML (see Section 5).



Title: System Conceptual Design Description	Owner: Selina	Date: 2022-06-06
NRAO Doc. #: 020.10.20.00.00-0005-REP		Version: A

The lifecycle concepts describe the project approach to design, assembly, integration, verification, scientific commissioning, operations, maintenance, and disposal. The Operations and Maintenance Concepts drive the design, dictating operation efficiencies to reduce total lifecycle cost. These operational requirements are captured at the stakeholder level. The Assembly, Integration, and Verification (AIV) and Commissioning and Science Validation (CSV) concepts are responsive to these stakeholder needs, and the associated AIV and CSV requirements are reflected at the system level.

Two observing programs, the Reference Observing Program [AD56] and Envelope Observing Program [AD57], capture a set of detailed use cases for analysis and derivation of supporting observing modes, calibration strategies, and data processing requirements. The reference observing program is limited to use cases necessary to support the key science goals of the facility, and represents a minimal use case set. The envelope observing program is expanded to reflect a more expansive complement of use cases that the facility could support in a notional year of observations.

In addition to the main System Requirements document, a set of global design standards capture other key specifications. These provide common references for requirements and guidance on the environmental conditions present at the site and within other defined areas, RFI and EMC requirements, and design specifications to address electrical standards and mechanical standards for reliability and maintainability, and the safety of both personnel and equipment. A distinction is drawn between the requirements that can be derived without constraining the system architecture (Level-I) and those that require assumptions about the system design for their derivation (Level-I.1).

The calibration requirements [AD15] in particular require significant assumptions about the system architecture, so these are captured at level-I.1. The observing modes framework [AD58] builds upon the functional operating modes of the system and defines standard observing modes that must be delivered to support the Reference Observing Program, while the Observing Modes Calibration Strategy [AD59] considers the functional needs for the observational strategies and data pipelines to provide calibrated data products for these standard modes. The lifecycle of observing modes from test modes to fully-commissioned standard observing modes available to general users is captured in [AD54].

The main system requirements document identifies nearly 400 system requirements, not including the global design standards and level-I.1 requirements. To provide some indication of significance, Table 1 shows the measures of performance (MOPs) identified as the most important for overall system effectiveness.

Parameter	Req. #	Value	Traceability
Effective Area/ T_{sys} Ratio	SYS1001	The effective area/ T_{sys} ratio of the system shall meet or exceed values given in Figure 2 (below) while operating in the precision environment conditions defined in 020.10.15.10.00-0001-SPE [AD04] and assuming 1 mm of PWV. This requirement must be met over 80% of the bandwidth of any given receiver (i.e. band edges are exempted).	SCI0100, SCI0102, SCI0106
Baseline Distribution	SYS1306	The distribution of baselines in a single integration snapshot at zenith with the ngVLA main array shall meet the requirements in Table 2, where A_1 is the geometric collecting area of a single antenna in the array and $N(b; b_1 < b < b_2)$ is the number of baselines between baseline lengths b_1 and b_2 .	SCI0100, SCI0102, SCI0103, SCI0108, SCI0118
Instantaneous Field of View	SYS1101	The system instantaneous FOV (FWHM), when scaled by center frequency, shall be larger than 2 arcmin at 28 GHz.	SCI0106, SCI104



Title: System Conceptual Design Description	Owner: Selina	Date: 2022-06-06
NRAO Doc. #: 020.10.20.00.00-0005-REP		Version: A

Parameter	Req. #	Value	Traceability
Shortest Baseline	SYS1302	The shortest baselines between antennas shall be shorter than 22 m, with a goal of 10 m.	SCI0104
Longest Baseline	SYS1301	The longest baseline between antennas in the main array shall be greater than 420 km with extended baselines (VLB) out to 8600 km.	SCI0103, SCI0118
Calibration Efficiency	SYS1061	Overheads for system calibration shall be minimized, with a goal of 90% of time spent on source for Standard Observing Modes.	SCI0100, SCI0102, SCI0106, STK1402, STK0704
System Availability	SYS2601	System Availability for Science Operations shall be greater than 80% of time, with more than 90% of antennas available in each band.	STK1402
Subarray Availability	SYS2602	It is a goal to achieve a sub-array level system availability of 95% of time, with at least 70% of antennas available for science operations.	STK1402
Number of Standard Observing Modes	SYS3002	Standard Observing Modes shall be developed to execute all planned observations in support of the KSG science use cases, as defined in the Reference Observing Program [AD56].	STK700, STK701, STK1000

Table 1 - System-level measures of performance (MOPs).

System A/T Specification

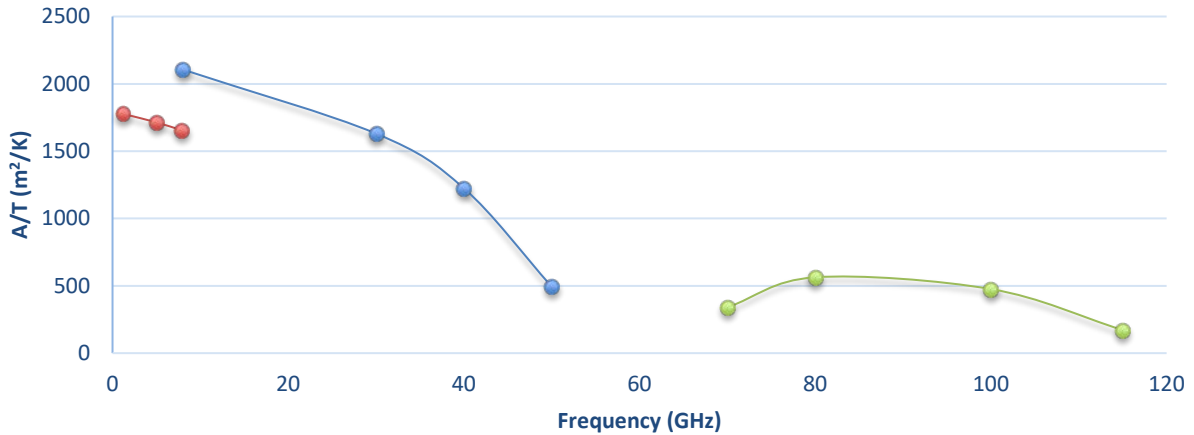

Figure 2 - System A/T specification in m²/K. (SYS1001)

Baseline Span: b_1, b_2	Collecting Area: $A_1 \sqrt{N(b: b_1 < b < b_2)}$
35 m, 100 m	> 1,600 m ²
100 m, 1 km	> 11,750 m ²
1 km, 4 km	> 17,900 m ²
4 km, 20 km	> 18,380 m ²
20 km, 500 km	> 21,250 m ²
500 km+	> 9,000 m ²

Table 2 – Radial distribution of system sensitivity in the main array. (SYS1306 / AAC0302)



Title: System Conceptual Design Description	Owner: Selina	Date: 2022-06-06
NRAO Doc. #: 020.10.20.00.00-0005-REP		Version: A

4 Lifecycle Concepts

4.1 Operations Concept

The observatory's concept for how to operate and maintain the facility is described in the ngVLA Operations Concept [AD08]. The Operations Concept was crafted by the Operations Work Group, comprised of members of the array operations, maintenance/engineering and science operations staff for the VLA and ALMA, reflecting a broad consensus of how the next facility should be operated, maintained, and integrated into the Observatory.

The facility will operate as a proposal-driven instrument with the science program determined by Principal Investigator (PI)-led proposals. Regular (likely annual) calls will solicit observing proposals, which will be peer reviewed and assigned a rank based on scientific merit and technical feasibility. Trained staff will incorporate the approved observations into dynamically scheduled blocks based on environmental conditions and array status, and in accordance with the user's scientific requirements.

Data will generally be delivered to PIs and the broader scientific community as pipeline produced and calibrated high-level data products (typically image cubes) [RD05]. Data and quality assured data products will be made available through an Observatory science archive. Data exploration tools will allow users to analyze the data directly from the archive, reducing the need for data transmission and reprocessing at the user's institution.

The delivery of quality assured high-level data products and provision of standard observing strategies will enable the Observatory to, first, support a broad community of scientific users that extends considerably wider than radio interferometry experts, and, second, facilitate multi-wavelength and multi-messenger astronomy. Innovative, non-standard observations not accessible through the standard modes will also be supported where the scientific goals are of sufficient merit.

Three primary centers will support the operation and maintenance of the array. A Maintenance Center will be located near the array core, where field technicians will provide day-to-day maintenance support for the antennas and associated array systems. An Array Operations and Repair Center will be located in Socorro, NM, and staff based there will repair failed system elements, provide system diagnostics and engineering support, and operate and supervise the array. A Science Operations Center (SOC) and a Data Center will be co-located in a large metropolitan area. The SOC will be the base for science operations and support staff, software operations, and related administration. Research and development activities will be split among these centers as appropriate. Technicians responsible for maintaining remote long-baseline antennas may be based at additional small service depots (Remote Support Stations).

This Operations Concept will further inform ngVLA operational requirements through derivation of detailed supplementary concepts for distinct phases of scientific and maintenance operations, as well as a subsequent Operations Plan, Transition Plan, and a Scientific & Technical Development Plan. The Operations Plan will fully describe the operational model to be employed following ngVLA construction, while the Transition Plan will cover the transition from VLA and VLBA operations to ngVLA operations. The Scientific & Technical Development Plan will describe the research and development activities necessary to advance the ngVLA's technical and user support capabilities after construction has ended and operations has begun. This includes future capability upgrades to maintain the scientific productivity of the facility. These operations plans will be delivered and reviewed as part of the Programmatic and Operations Conceptual Design Review, which will follow the Technical Conceptual Design Review.

4.2 Assembly, Integration, and Verification (AIV) Concept

The ngVLA Assembly Integration and Verification Concepts detailed in [AD52]. It describes the production and construction concept for work package deliverables, the degree of verification, and the



Title: System Conceptual Design Description	Owner: Selina	Date: 2022-06-06
NRAO Doc. #: 020.10.20.00.00-0005-REP		Version: A

point of delivery. It then elaborates on the assembly of these deliverables into integrated systems and defines a set of progressive functional verification milestones to the system requirements. The AIV concept describes these steps qualitatively, identifying likely resources and supporting infrastructure to achieve these goals.

The AIV concept imposes requirements on systems packaging, element deployment schedule, and ancillary equipment or processes required for component or subsystem verification. These requirements and their impacts are reflected in the system requirements and this conceptual design. The overall ngVLA construction concept has work packages delivering qualified subsystems or sub-assemblies to the AIV team, the AIV team assembling these into integrated and verified systems, and handing over these verified systems to the Commissioning and Science Validation (CSV) team for the progressive commissioning of capabilities. Construction ends with the hand-over of a commissioned telescope to the Operations team. These hand-offs are expected to be incremental, with a goal of completing the construction phase in a ten year period.

The technical AIV concept relies on line replaceable units (LRUs) that are verified independently before integration into more complex subsystems. LRUs and their sub-assemblies will generally be built to specification on contract. The ngVLA project team will act as system integrator. Subsystem architectures are scalable where required, ensuring that they can be deployed and tested incrementally, consistent with the overall AIV plan.

4.3 Commissioning and Science Validation (CSV) Concept

The ngVLA Commissioning and Science Validation Concept is detailed in [AD53]. The split between AIV and CSV is based on team specialization. AIV aims to deliver subsystems to specification and an integrated system with demonstrated core functionality. CSV assumes these verified components, performs additional integrated testing to verify system performance, and develops operational processes that enable observing modes for users.

The CSV concept defines a set of early commissioning milestones that show a progressive system integration and provide incremental observing capabilities. Early milestones such as establishing first fringes and phase closure will be performed jointly by the AIV and CSV teams. The teams will separate their responsibilities after the verification of functional subarrays, which will enable parallel work by both groups. Independent CSV milestones then progress to integrated performance testing, enabling operation from scheduling blocks, progressing towards basic instrumental calibration, and demonstration of the first interferometric observing modes that can be made available to users. CSV ends upon delivery of all capabilities required to meet the Science Requirements and Operations Concept and facility handover to Operations. The general exit criterion is routine data acquisition, meeting quality assurance standards, for any delivered standard observing mode using a standard scheduling block (SB) created using the Proposal Submission Tool (PST) and post-processed by the automated data processing system.

The requirements imposed by the CSV concept are captured in the system requirements and reflected in this conceptual design. Primarily these consist of engineering and commissioning interfaces to the system to enable debugging and mode tests without running the full software stack from proposal submission forward.



Title: System Conceptual Design Description	Owner: Selina	Date: 2022-06-06
NRAO Doc. #: 020.10.20.00.00-0005-REP		Version: A

5 System Architecture

The ngVLA System Architecture is described in:

- ngVLA Preliminary System Architecture Description, 020.10.20.00.00-0002-REP
- Antenna Electronics Block Diagrams, 020.30.00.00.00-0005-BLK
- ngVLA Product Breakdown Structure, 020.10.10.05.00-0001-LIS
- ngVLA N² Matrix, 020.10.40.00.00-0001-DWG

The system-level architecture is implemented in the Systems Modeling Language (SysML) and provides a functional decomposition of the system along with a structural architecture that is consistent with the Product Breakdown Structure (PBS) [AD12] of the ngVLA Conceptual Design. This model also includes a database of the requirements from the science and stakeholder level through sub-system requirements (L0-L1-L2), enabling traceability between requirements levels. Future iterations of this model may allocate these requirements to structural elements in the model as a tool for gap analysis leading up to the PDR.

The system architecture aims to be:

- loosely coupled between sub-systems, to enable parallel development with clean interfaces;
- scalable and extensible to adjust to evolving performance requirements and programmatic constraints; and
- maintainable over the instrument's lifetime, inclusive of planned obsolescence and upgrades at the sub-system or component level.

For a functional overview of the system architecture, Figure 3 provides a high-level view of the system starting with user interfaces. A project starts with the submission of a proposal by a Principal Investigator (PI) using the Proposal Management tools, and ends with the PI analyzing their high-level data products through the Data Product Analysis and Visualization tools.

Additional layers of the architecture address the monitoring and control of the system, the signal path and generation of data products for the archive, and the necessary supporting infrastructure and operational support systems. Each functional block described in the figure is allocated to an element of the product breakdown structure for aggregation into sub-systems as part of a structural and organizational view of the system.

The architecture will be baselined as part of this conceptual design technical baseline, but will continue to be elaborated at lower levels through to the system preliminary design review. The architecture will be considered complete in the preliminary design phase when all sub-system interfaces are defined and baselined.



Title: System Conceptual Design Description	Owner: Selina	Date: 2022-06-06
NRAO Doc. #: 020.10.20.00.00-0005-REP		Version: A

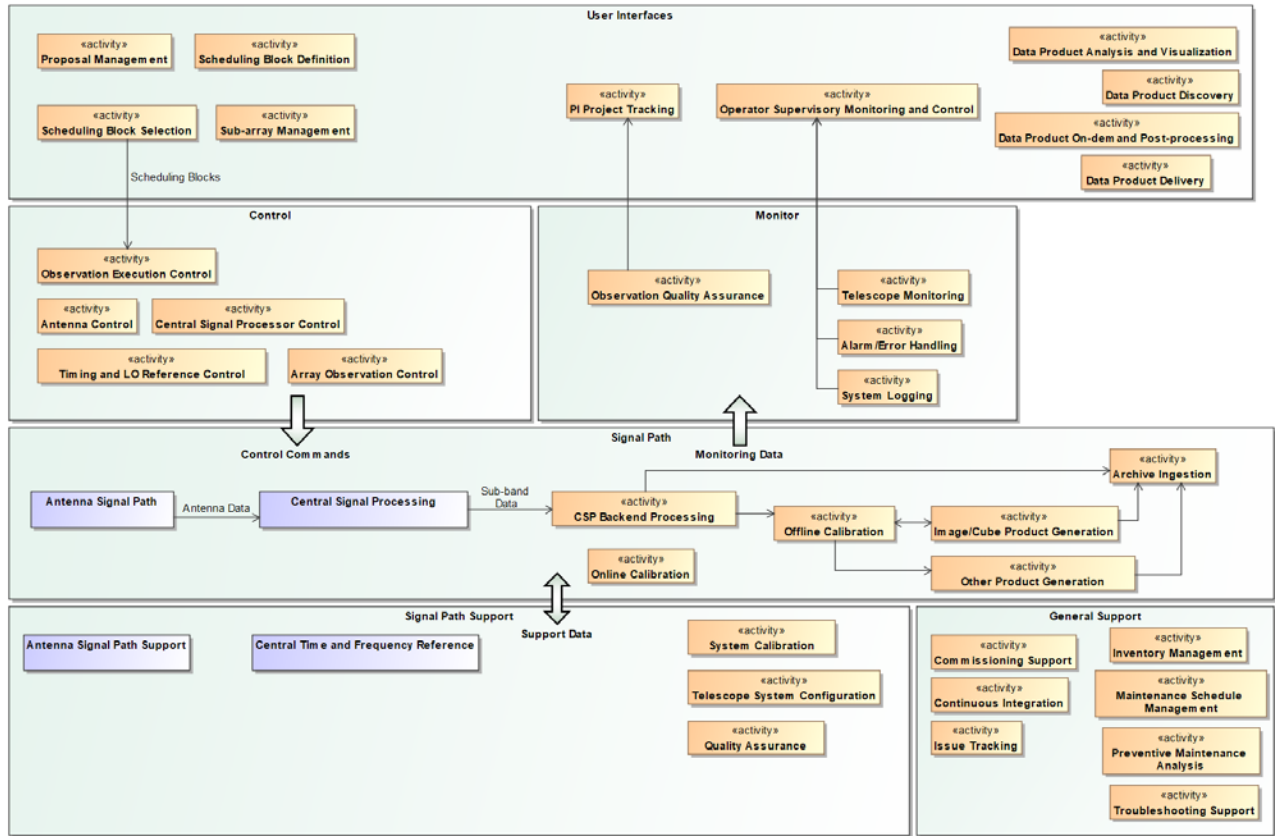

Figure 3 – The high-level ngVLA Functional System Architecture. [AD09]

6 System Design Overview

This section provides a system-level overview of the conceptual design and describes the facility concept, its projected performance, and data products delivered to users. Major subsystem concepts follow in Section 7. A summary of the trade space and options explored before settling on this system concept is available in [AD55].

6.1 Overview

The ngVLA is planned as an astronomical observatory that will operate at centimeter to millimeter wavelengths (25 to 0.26 centimeters, corresponding to a frequency range extending from 1.2 GHz to 116 GHz). The observatory will be a synthesis radio telescope constituted of three array components:

- A main array of 214 18-meter reflector antennas, operating in a phased or interferometric mode, will sample a wide range of scales from tens of meters to 1000 km. A dense core and spiral arms provide high surface brightness sensitivity, with mid-baseline stations enhancing angular resolution.
- A short baseline array (SBA) of 19 6-meter reflector antennas will capture a portion of the larger angular scales undetected by the main array. The SBA may be combined with four (TBC) 18-meter main array antennas used in total power mode to completely fill in the central hole in the (u,v) -plane left by the 6-meter dishes.
- A long baseline array (LBA) will add 30 18-meter reflector antennas in ten clusters providing continental-scale baselines ($B_{MAX} \sim 8794$ km). The LBA will sample a broad range of scales for standalone sub-array use as well as for integrated operation with the main array.



Title: System Conceptual Design Description	Owner: Selina	Date: 2022-06-06
NRAO Doc. #: 020.10.20.00.00-0005-REP		Version: A

In total, the ngVLA will have approximately ten times the sensitivity of the VLA and ALMA, continental-scale baselines providing sub-milliarcsecond-resolution, and a dense core on km-scales for high surface brightness sensitivity. Such an array bridges the gap between ALMA, a superb sub-millimeter array, and the future SKA1, optimized for longer wavelengths. The array also provides enhanced frequency coverage, image fidelity and sensitivity for the highest angular resolution use cases, providing continuity of service for critical VLBA geodesy and astrometry missions.

The array’s dense core and signal processing center will be located at the Very Large Array site on the Plains of San Agustin, New Mexico. The high desert plains of the southwest US, at over 2000 m elevation, provide excellent observing conditions for the frequencies under consideration, including reasonable phase stability and good transmission at 3 mm wavelength over a substantial fraction of the year.

The main array will include stations in other locations throughout New Mexico, west Texas, eastern Arizona, and northern Mexico. Long baseline stations are located in Hawaii, Washington, California, Iowa, West Virginia, New Hampshire, Puerto Rico, the US Virgin Islands, and Canada.

Operations will be conducted from both the VLA Site and the Array Operations and Repair Centers in Socorro, NM. A Science Operations Center and Data Center will be located in a large metropolitan area and will be the base for science operations and support staff, software operations and related administration. Research and development activities will be split among these centers as appropriate.

The facility will be operated as a proposal-driven instrument. The fundamental data products for ngVLA users will be “science-ready” high-level data products (images and cubes) generated using calibration and imaging pipelines created and maintained by the project. Archiving both the high-level pipeline products and “raw” visibilities and calibration tables will retain the option of future re-processing and archival science projects.

6.2 Array Performance

Table 3 summarizes the array’s predicted performance, updated from those originally documented in [RD09].

Receiver Band	B1	B2	B3	B4	B5	B6	Notes
Center Frequency, f	2.4 GHz	8 GHz	16 GHz	27 GHz	41 GHz	93 GHz	
Band lower frequency [GHz]	1.2	3.4	12.3	20.5	30.5	70.0	a
Band upper frequency [GHz]	3.5	12.3	20.5	34.0	50.5	116.0	a
Field of view FWHM [arcmin]	24.9	7.4	3.6	2.1	1.4	0.6	b
Aperture efficiency	0.83	0.94	0.94	0.92	0.89	0.65	b, e
Effective Area, $A_{\text{eff}} \times 10^3$ [m ²]	51.4	58.2	58.4	57.1	55.0	40.3	b, e
System temp, T_{sys} [K]	17	22	24	32	47	65	a, e
Max inst. bandwidth [GHz]	2.3	8.8	8.2	13.5	20.0	20.0	a, f
Antenna SEFD [Jy]	232	265	292	397	603	1136	a, b
Resolution of max. baseline [mas]	2.97	0.89	0.43	0.26	0.17	0.08	c
Continuum rms, 1 hr [μ Jy/beam]	0.24	0.14	0.16	0.17	0.21	0.40	d, e



Title: System Conceptual Design Description	Owner: Selina	Date: 2022-06-06
NRAO Doc. #: 020.10.20.00.00-0005-REP		Version: A

Receiver Band	B1	B2	B3	B4	B5	B6	Notes
Center Frequency, f	2.4 GHz	8 GHz	16 GHz	27 GHz	41 GHz	93 GHz	
Line width, 10 km/s [kHz]	78	262	547	909	1351	3102	
Line rms, 1 hr, 10 km/s [μ Jy/beam]	35	24	20	19	22	31	d, e

- (a) Six-band conceptual design receiver configuration.
- (b) 244 18 m aperture antennas. Unblocked aperture with 160 μ m surface.
- (c) Rev. D 2021 Configuration. [RD50]
- (d) Point source sensitivity using natural imaging weights, dual polarization, and all baselines.
- (e) Averaged over the band. Assumes 1 mm PWV for Band 6, 6 mm PWV for others; 45 deg elev. on sky for all.
- (f) Up to 20 GHz of bandwidth per polarization.

Table 3 - ngVLA key performance metrics.

The continuum and line rms values in Table 3 are for point source sensitivity with a naturally weighted beam. Imaging sensitivity is estimated based on [RD22, RD47] and provided as a function of angular resolution in Table 4. The table is by necessity a simplification. The imaging sensitivity will vary from these reported values depending on the quality of the (sculpted) synthesized beam (defined as the ratio of the power in the main beam attenuation pattern to the power in the entire beam attenuation pattern as a function of the FWHM of the synthesized beam [AD01]) required to support the science use case.

The brightness sensitivity of an array is critically dependent on the array configuration. The ngVLA has the competing desires of both good point source sensitivity at full resolution, and good surface brightness sensitivity on scales similar to the primary beam size. Different array configurations that might provide a reasonable compromise through judicious weighting of the visibilities for a given application have been explored [RD11] (see [RD12] for similar studies for the SKA). It is important to recognize the fact that for any given observation, from full resolution imaging of small fields, to imaging structure on scales approaching that of the primary beam, some compromise in these metrics must be accepted to enable a practical and flexible general-purpose facility.

Receiver Band	B1	B2	B3	B4	B5	B6
Center Frequency, f	2.4 GHz	8 GHz	16 GHz	27 GHz	41 GHz	93 GHz
Resolution [mas]	1000					
Continuum rms, 1 hr, Robust [μ Jy/beam]	0.32	0.21	0.28	0.36	0.57	2.02
Line rms 1 hr, 10 km/s Robust [μ Jy/beam]	47.2	36.4	35.0	40.4	61.0	159.4
Brightness Temp (T_B) rms continuum, 1 hr, Robust [K]	7.0E-02	4.2E-03	1.3E-03	6.0E-04	4.0E-04	3.0E-04
T_B rms line, 1 hr, 10 km/s, Robust [K]	9.97	0.69	0.17	0.07	0.04	0.02
Resolution [mas]	100					
Continuum rms, 1 hr, Robust [μ Jy/beam]	0.27	0.17	0.21	0.23	0.29	0.62
Line rms 1 hr, 10 km/s Robust [μ Jy/beam]	39.8	29.4	25.7	25.2	30.9	49.0
Brightness Temp (T_B) rms continuum, 1 hr, Robust [K]	5.90	0.34	0.09	0.04	0.02	0.01
T_B rms line, 1 hr, 10 km/s, Robust [K]	839.8	55.9	12.2	4.2	2.2	0.7
Resolution [mas]	10					
Continuum rms, 1 hr, Robust [μ Jy/beam]	0.26	0.15	0.17	0.19	0.25	0.49
Line rms 1 hr, 10 km/s Robust [μ Jy/beam]	38.4	25.9	21.7	21.2	26.0	39.0



Title: System Conceptual Design Description	Owner: Selina	Date: 2022-06-06
NRAO Doc. #: 020.10.20.00.00-0005-REP		Version: A

Receiver Band	B1	B2	B3	B4	B5	B6
Center Frequency, f	2.4 GHz	8 GHz	16 GHz	27 GHz	41 GHz	93 GHz
Brightness Temp (T_B) rms continuum, 1 hr, Robust [K]	579.3	29.7	7.9	3.1	1.8	0.7
T_B rms line, 1 hr, 10 km/s, Robust [K]	8.1E+04	4913	1033	354	188	55
Resolution [mas]	1					
Continuum rms, 1 hr, Robust [μ Jy/beam]	-	3.2	0.2	0.2	0.2	0.4
Line rms 1 hr, 10 km/s Robust [μ Jy/beam]	-	510.5	31.8	18.9	23.0	34.0
Brightness Temp (T_B) rms continuum, 1 hr, Robust [K]	-	63233.4	1103.0	277.0	161.2	60.5
T_B rms line, 1 hr, 10 km/s, Robust [K]	-	9.7E+06	1.5E+05	3.1E+04	1.7E+04	4.8E+03
Resolution [mas]	0.1					
Continuum rms, 1 hr, Robust [μ Jy/beam]	-	-	-	-	-	4.5
Line rms 1 hr, 10 km/s Robust [μ Jy/beam]	-	-	-	-	-	355.3
Brightness Temp (T_B) rms continuum, 1 hr, Robust [K]	-	-	-	-	-	6.3E+04
T_B rms line, 1 hr, 10 km/s, Robust [K]	-	-	-	-	-	5.0E+06

Table 4 - Projected imaging sensitivity as a function of angular resolution. All values at center frequency and accounting for typical beam sculpting weights [RD47, 50].

Imaging sensitivity will be dependent on the required resolution and imaging fidelity. Figure 4 and Figure 5 show the effects of adjusting imaging weights to vary the resolution and quality of the point spread function (PSF). These figures are based on a four-hour simulation at 30 GHz using the 244 antenna array configuration (Revision D, Main Array and Long Baseline Array combined), for a source at +24° Declination observed during transit. The reported beam size is the geometric mean of the major and minor axes full width at half maximum (FWHM) of the synthesized beam as parameterized by Gaussian fitting in the CASA ‘tclean’ task. [RD47, 50]

The centrally condensed antenna distribution leads to a naturally weighted beam that is not well characterized by a Gaussian function. Specific science applications may need to adjust the (u,v)-weighting and image parameters to sculpt a synthesized beam that is adequate for the particular science goal being considered. The results in Figure 4 and Figure 5 should be considered representative of the possibilities, and optimizing sensitivity vs. resolution has been a major area of investigation during telescope development. The array configuration will be baselined as part of the CDR data package, and subject to configuration control leading up to the PDR.

To account for the change in sensitivity due to use of imaging weights, relative to the naturally weighted rms (σ_{NA}), an efficiency factor η_{weight} is adopted such that the expected image rms after weighting is $\eta_{weight} * \sigma_{NA}$. The sensitivity calculations in Table 4 include η_{weight} , estimated using the blue and red data series in Figure 4 scaled by frequency.

Title: System Conceptual Design Description	Owner: Selina	Date: 2022-06-06
NRAO Doc. #: 020.10.20.00.00-0005-REP		Version: A

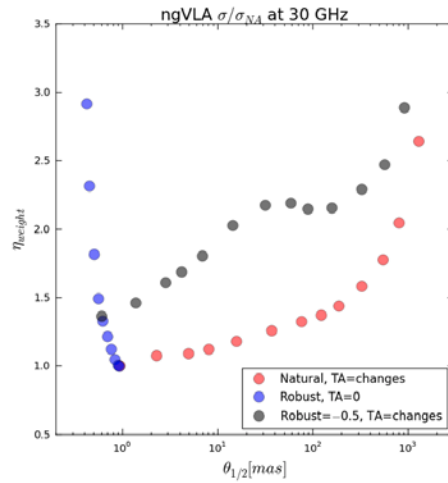

Figure 4 - Image noise (rms) at different angular resolutions (FWHM) achieved by varying the imaging weights, simulated at 30 GHz, for the Main Array and LBA revision D. The noise has been scaled relative to that of the naturally weighted image (σ_{NA}). The red symbols correspond to use of a (u,v) taper and natural weights, and the blue symbols to Briggs robust weighting without a taper. The gray symbols are for Briggs robust = -0.5 and a varying (u,v) taper, which has a large effect on beam quality. [RD50]

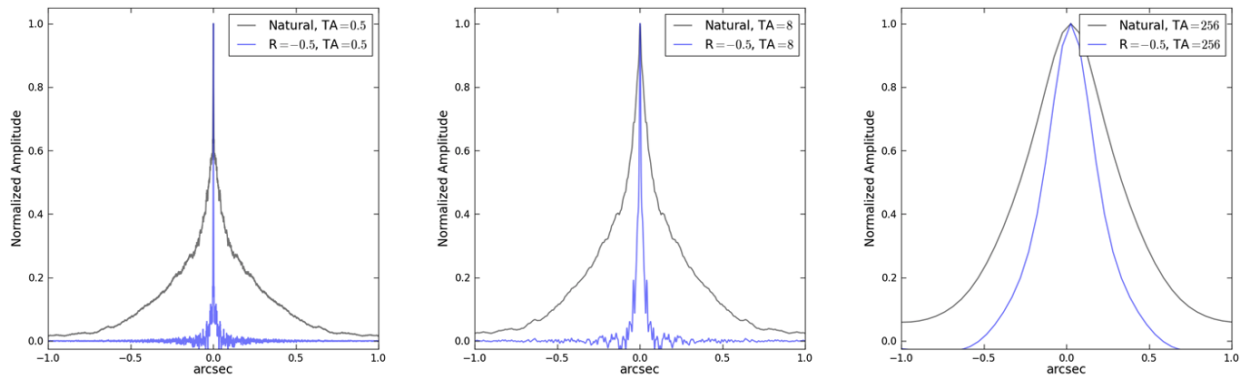

Figure 5 – Simulated 30 GHz PSFs for the present ngVLA reference array (Rev D), including all 244 18m antennas, over a range of resolutions, showing the effect of different imaging weights (TA: uv-taper in mas, R: Briggs robust parameter). The PSFs are a selection of the data presented in Figure 4. The FWHM of a Gaussian fit to the beams are, from left to right for the NA curves (black) are: 2.3, 36.6, and 549 mas; the values for the Robust weighted curves (blue) are: 1.4, 14.3, and 326 mas. These examples illustrate how combinations of robustness and tapering allow for a beam of much higher quality, i.e., greatly reduced beam skirts, but at the expense of sensitivity. [RD50]

6.3 New Parameter Space

With an order of magnitude improvement in sensitivity and resolution compared to existing and planned facilities, the ngVLA opens up new parameter space ripe for discovery. Furthermore, the system capabilities will yield transformational advances in areas of astrophysics that are also highly synergistic with the science goals of next-generation ground-based optical/infrared (OIR) and NASA missions.

Figure 6 shows a slice through the parameter space, angular resolution versus frequency, covered by the ngVLA along with other existing and planned facilities that are expected in the 2030s at all wavelengths. The maximum baselines of the ngVLA imply an angular resolution of better than 0.5mas at 1 cm.

Title: System Conceptual Design Description	Owner: Selina	Date: 2022-06-06
NRAO Doc. #: 020.10.20.00.00-0005-REP		Version: A

Coupled with the high sensitivity of the array, this angular resolution provides a unique window into the formation of terrestrial planets in Solar systems like our own by providing AU-scale resolution at the distance of the nearest active star-forming regions (7 mas corresponds to 1 AU at 140 pc).

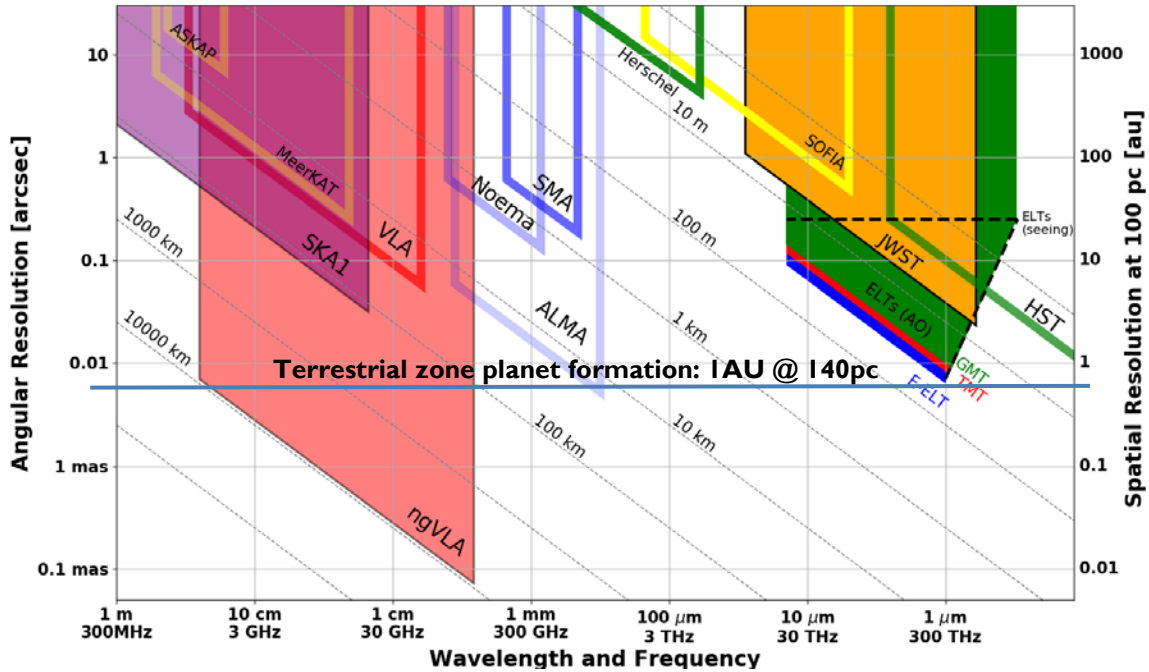

Figure 6 - Spatial resolution versus frequency set by ngVLA maximum baselines as compared to that of other existing and planned facilities.

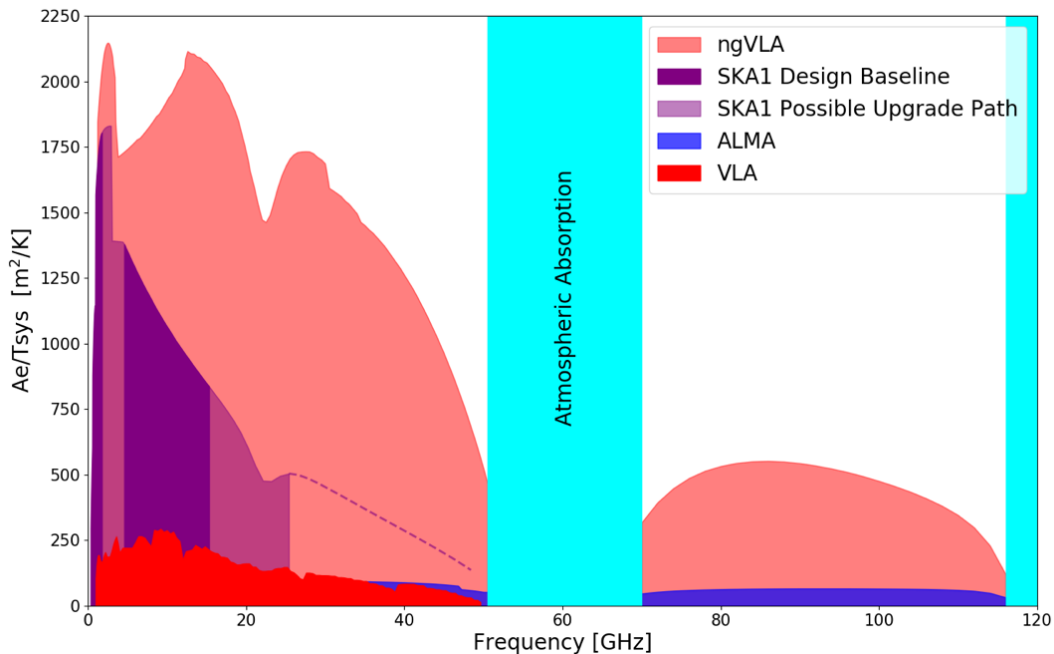

Figure 7 - Effective collecting area versus frequency for ngVLA as compared to that for other existing or planned facilities. Note that lower and higher frequencies are not shown (e.g., SKA-I will extend to below 100 MHz and ALMA extends up to about a THz). Both the SKA-design baseline (dark purple) and possible upgrade paths (light purple) are shown, inclusive of the MeerKAT array. [RD18]



Title: System Conceptual Design Description	Owner: Selina	Date: 2022-06-06
NRAO Doc. #: 020.10.20.00.00-0005-REP		Version: A

Figure 7 shows a second slice through parameter space: the ratio of effective collecting area to system temperature versus frequency. A linear-linear plot highlights the parameter space opened by the ngVLA. Note that the SKA-I will extend to below 100 MHz while ALMA extends up to almost a THz.

Other relevant aspects of telescope phase space include field of view, mapping speed, surface brightness sensitivity, bandwidth, dynamic range, etc. However, here we have presented the two principal and simplest design goals, namely, maximum spatial resolution and the ratio of effective collecting area to system temperature (as a reasonable proxy for system imaging sensitivity).

6.4 Observing Modes & Data Products

The standard method of delivery of scientific data from ngVLA to PIs will be automatically generated and quality assured high-level data products. ngVLA data rates will be high enough to make data reduction at a PI's home institution challenging, but low enough that real-time processing of the visibilities (à la SKA) is not required [RD33].

As described in Section 2, two observing programs, the Reference Observing Program [AD56] and Envelope Observing Program [AD57], capture a set of detailed use cases for analysis and derivation of supporting observing modes, calibration strategies, and data processing requirements. The reference observing program is limited to use cases necessary to support the key science goals of the facility, and represents the minimal use case set. The envelope observing program is expanded to reflect a more expansive complement of use cases that the facility could support in a notional year of observations.

A key system requirement is to deliver standard observing modes, fully-commissioned observing capabilities that routinely produce quality-assured high-level data products, for all observations required in the ROP. The Observatory must therefore provide sufficient computing resources for the data processing associated with normal operations using standard modes and capabilities (including delivery of high-level data products to PIs) as well as reasonable reprocessing by PIs and a broader community of users of archival (public) data. The sizing of the computing resources has been informed by an assessment of the computational intensity of the use cases that make up the reference observing program, scaled to a full year of operations [RD33].

Observational strategies and data reduction pipelines must also be defined. The observing modes framework [AD58] builds upon the functional operating modes of the system and defines the standard observing modes that must be delivered within the scope of the construction project. The Observing Modes Calibration Strategy [AD59] considers the functional needs for the observational strategies and data pipelines to provide calibrated data products for these standard modes. Finally, the lifecycle of observing modes from test modes to fully-commissioned standard observing modes available to general users is captured in [AD54].

The definition and delivery of ngVLA data products by observing mode is being informed by NRAO's development of Science Ready Data Products via the ALMA data pipeline and the efforts already underway to extend this approach to the VLA [RD05, RD06]. Standard and optimized data products are anticipated to meet both the needs of the original PI for ngVLA observations, and the scientific goals of subsequent users of publicly available data from the Data Archive. Raw visibilities, calibration tables and high-level data products will all be stored and made available through the Data Archive, as will some classes of user-generated data products where they can be suitably quality assured.

Large and Legacy [RD34] scale projects will need to identify data processing requirements and resources, and may require additional computing resources to be made available from non-Observatory sources in order to be scheduled. Large and Legacy projects will likely not be offered until well after the start of science operations, but are incorporated into the operations plan.



Title: System Conceptual Design Description	Owner: Selina	Date: 2022-06-06
NRAO Doc. #: 020.10.20.00.00-0005-REP		Version: A

The Observatory will provide separate software packages to the user community for processing ngVLA visibilities and for data analysis. Both packages will be executable on Observatory computer resources and on non-Observatory computers, though the visibility processing software is likely to be aimed primarily at use only by domain experts.

6.5 Site Selection

The VLA site on the Plains of San Agustin was originally chosen as the location for the array because of its desirable properties: relatively flat, undeveloped (to minimize RFI) yet not too remote (for accessibility), at low latitude (for sky coverage), and at high elevation (to minimize atmospheric effects) [RD43]. These properties still hold true, and motivate examination of the VLA site as the center of the ngVLA.

Furthermore, with extensive existing infrastructure, the VLA site leverages an already existing system of power, fiber, and buildings, which will reduce cost. The presence of an existing VLA operations staff and organization also present significant added value to the project, especially in the commissioning and early operations phase of the ngVLA, as developing these capabilities is typically a multi-year effort.

The three main environmental or atmospheric quantities that may affect data, and what is known about them at the VLA site, are discussed in the following sections.

6.5.1 RFI

The VLA site is remote enough that Radio Frequency Interference (RFI) is not a debilitating problem, so it will be possible to observe at the lower frequencies of the ngVLA [RD40]. Furthermore, the ngVLA will benefit from advanced studies of RFI detection and excision that are currently ongoing [RD42]. The degree of RFI characterization of the site reduces the risk in site selection, and leveraging existing infrastructure could create significant cost savings for both the construction and operation of the array.

Given the large extent of ngVLA ($B_{MAX} \sim 8794$ km), it is clear that the antennas located outside the plains will experience different RFI environments than at the VLA site. However, there are locations which are relatively free of locally generated RFI (downward RFI from orbiting satellites is ubiquitous and nearly site-independent), and the US southwest has many such locations [RD41]. Proximity to strong transmitters and terrain shielding are two factors that are considered in remote site selection.

6.5.2 Atmospheric Phase Stability

Analysis of data from the VLA site atmospheric phase monitor shows that fast switching phase calibration at 3 mm should be viable for most of the year with a 30-second total calibration cycle time [RD13]. This analysis was based on one year of atmospheric phase monitoring at the VLA site [RD39]. A much longer time base of these values is now available. Figure 8 shows median values of the rms phase on the 300 m E-W baseline of the atmospheric phase monitor from 1995 through 2017, plotted as a function of UTC hour and month.

It is easy to see that these fluctuations are small for much of the time, and only become greater than 10° (rms @ 11.7 GHz, over 10 minutes) in the summer during daytime. Little information is available on phase fluctuations at locations outside the plains; this is a topic to be studied to determine the ability to use the remote sites at the highest frequencies of ngVLA.

Note that there should also be a 25 mJy calibrator source within 2° in 98% of observed fields, ensuring short slews. Such a calibrator is adequate to ensure that the residual rms phase noise due to the signal-to-noise ratio on the phase calibrator is much less than that due to the troposphere, even for a 30 sec cycle time with only 3 sec on the calibrator each visit [RD13].

The project is also developing radiometric phase correction techniques (water vapor radiometry) to increase the total phase calibration cycle time. The high sensitivity of the ngVLA opens up self-calibration



Title: System Conceptual Design Description	Owner: Selina	Date: 2022-06-06
NRAO Doc. #: 020.10.20.00.00-0005-REP		Version: A

on short timescales, which is also being explored as a possible central element in attaining the high dynamic range requirements.

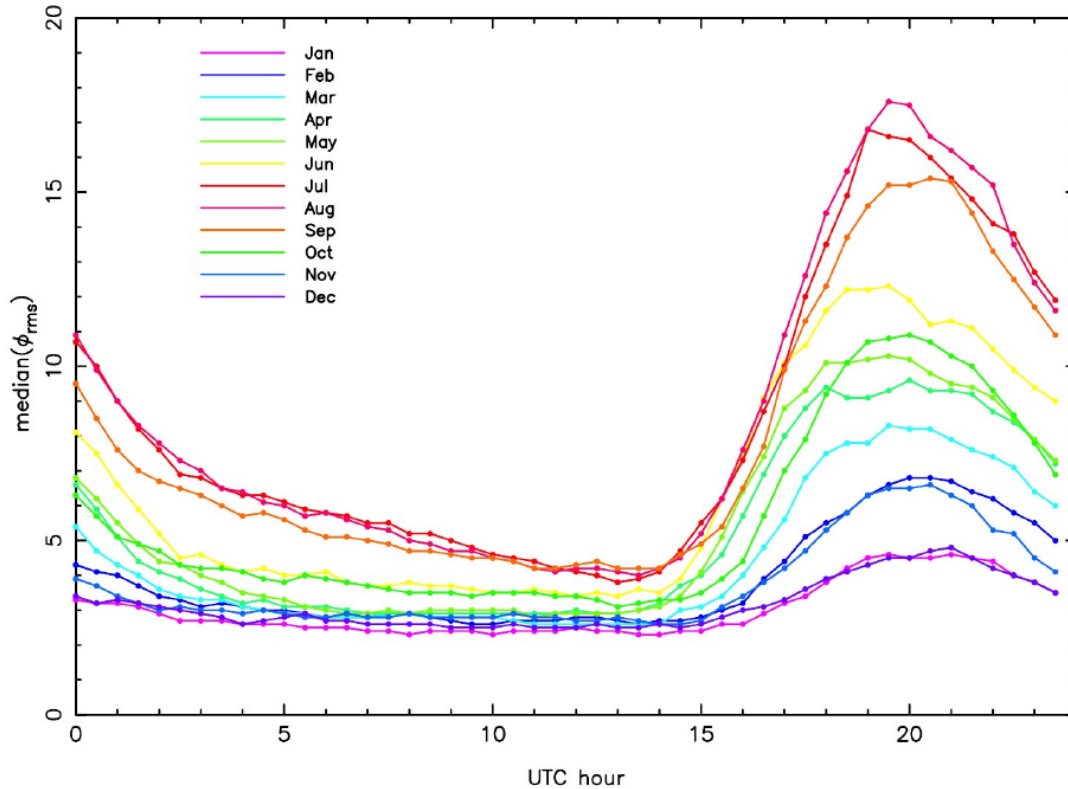

Figure 8 - The median rms phase measured with the atmospheric phase monitor at the VLA (300 m E-W baseline, 11.7 GHz beacon), from 1995 to 2017. Measurements are calculated over a ten-minute period after subtracting any linear trend. Different months are plotted as different colors, as shown in the legend.

6.5.3 Atmospheric Opacity

While at centimeter wavelengths atmospheric opacity is a relatively minor issue compared to phase stability, it becomes a much bigger issue at millimeter wavelengths. Similar to the atmospheric phase stability data, there is a long-time baseline of surface weather data at the VLA site. This can be used to estimate the atmospheric Precipitable Water Vapor (PWV), which is the main contributor to the fluctuating part of atmospheric opacity [RD38].

Figure 9 shows this value for the years 2010 through 2017. In winter months, the median over all hours is around 3 mm, and over the entire year the median over all hours is 5.4 mm. Vertical opacity for 5.4 mm PWV at 90 GHz is less than 7%, so opacity should not be a problem for ngVLA.

As with RFI and phase stability, there is little information on atmospheric opacity at other locations, though it is almost always clear that higher sites have less opacity. The project does have access to surface weather data, and to radiosonde launch data (twice per day) from NOAA for some tens of sites across the southwest US, which will be the subject of a future study to determine opacity properties across the extent of ngVLA.



Title: System Conceptual Design Description	Owner: Selina	Date: 2022-06-06
NRAO Doc. #: 020.10.20.00.00-0005-REP		Version: A

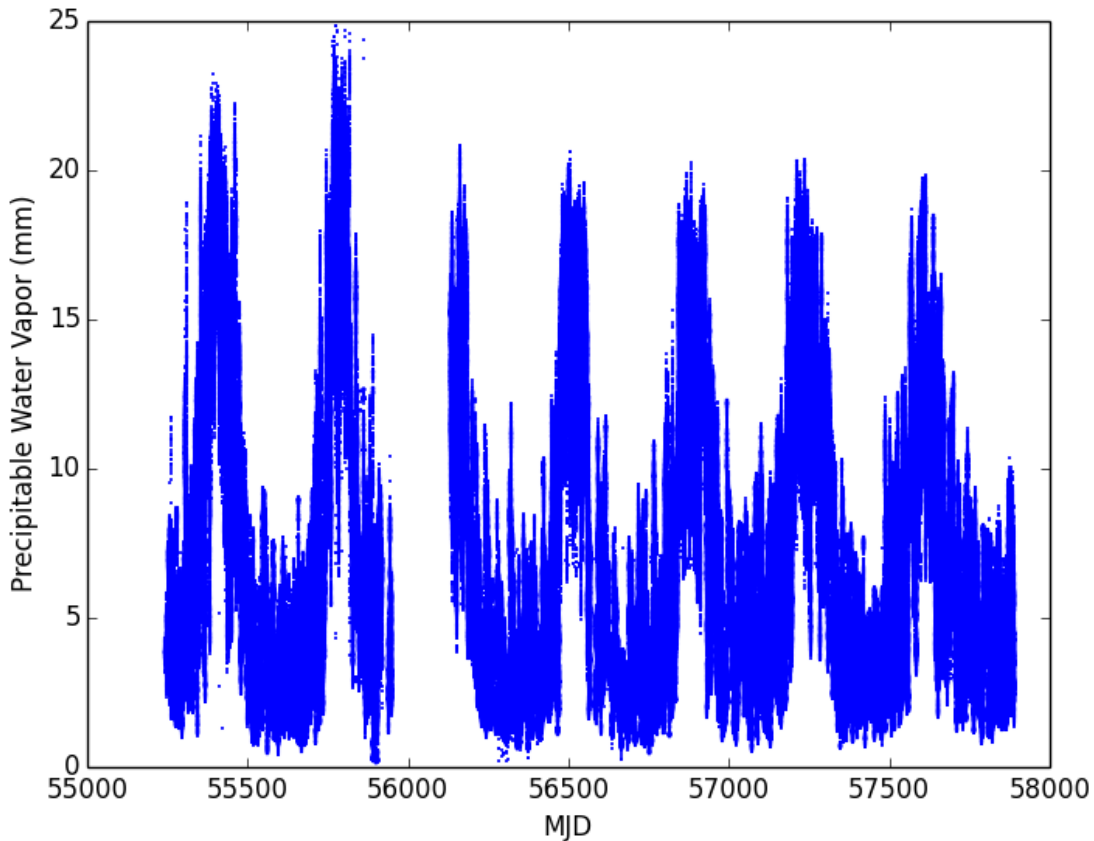

Figure 9 - PWV at the VLA site, estimated using surface weather measurements, from 2010 to 2017. Note that a PWV of 6 mm produces an opacity of less than 7% at 90 GHz.

6.5.4 Final Site Selection

Because of the quality of the site for both low- and high-frequency observing, and the existing operations facilities, staff and infrastructure, ngVLA is centered near the current VLA. The southwest US and northern Mexico are sparsely populated and the antennas within 1000 km of the VLA are sited to select remote, radio quiet, and dry sites, while still considering the logistics of site access, electrical infrastructure, and fiber optic network topology. The long baseline array sites were selected to minimize site impact and leverage shared infrastructure of other existing observatories, so sites operated by the VLBA or other observatories are preferred. Note that the VLA site was used for acceptance testing of the original ALMA antennas, including observations up to 230 GHz, and the experience was that the VLA site at 2124 m elevation is a high-quality 90 GHz site—comparable to the Plateau de Bure site in overall performance [RD04].



Title: System Conceptual Design Description	Owner: Selina	Date: 2022-06-06
NRAO Doc. #: 020.10.20.00.00-0005-REP		Version: A

7 Conceptual Design

7.1 Array Configuration

The requirements and conceptual design of the Array Configuration for the facility are described in the following documents [AD13–14]:

- ngVLA Array Configuration Requirements, 020.23.00.00.00-0001-REQ
- ngVLA Array Design Description, 020.23.00.00.00-0002-DSN

Additional supporting material that informed the selected conceptual design can be found in the following documents. Included memos present the detailed science case simulations demonstrating the ability of the proposed configuration to successfully complete the ngVLA KSGs.

- Possible Configurations for the ngVLA, ngVLA Memo No. 3
- Imaging Capabilities: Protoplanetary Disks Comparison, ngVLA Memo No. 11
- The Strength of the Core, ngVLA Memo No. 12
- Short Spacing Considerations for the ngVLA, ngVLA Memo No. 14
- More on Synthesized Beams and Sensitivity, ngVLA Memo No. 16
- ngVLA Short Baseline Array Configuration, ngVLA Memo No. 43
- Resolution & Sensitivity of ngVLA-RevB, ngVLA Memo No. 47
- Snapshot UV Coverage of the ngVLA: An Alternate Configuration, ngVLA Memo No. 49
- Short Spacing Issues for Mapping Extended Emission: Milky Way Case Study, ngVLA Memo No. 54
- Taperability Study for the ngVLA and Performance Estimates, ngVLA Memo No. 55
- Sculpting of the Synthesized Beam and Image Fidelity Study of KSG 1: Imaging of Protoplanetary Disks, ngVLA Memo No. 65
- Demonstration & Analysis of ngVLA core + Short Baseline Array Extended Structure Imaging v2, ngVLA Memo No. 67
- A Study of ngVLA Subarray Efficiency: Plains + Fractions of the Core, ngVLA Memo No. 72
- Subarray Selection for the Reference Observing Program, ngVLA Memo No. 76
- The NGVLA Long Baseline Array: Configuration Suggestions, ngVLA Memo No. 84
- Comparison of Alternative Configurations for the ngVLA Plains Subarray Addendum, ngVLA Memo No. 85
- Imaging Evaluation of Two Mid Configurations, ngVLA Memo No. 86
- Image Fidelity Study of KSG 3 (NGA8): Imaging Molecular Gas in Nearby Galaxies Addendum, ngVLA Memo No. 89
- Configuration: Reference Design Rev D Description, ngVLA Memo No. 92
- Evaluation of the Revision D Array Configuration for Stellar Imaging, ngVLA Memo No. 98

The ngVLA will operate as both a single array and a set of independent subarrays, with the array logistically divided into three main subarrays: a main interferometric array (MA), a short baseline array (SBA), and a long-baseline array (LBA), providing a wide range of angular scales.

The main array configuration will consist of 214 18-meter antennas at the approximate locations shown in Figure 10. The array collecting area is distributed to provide high surface brightness sensitivity on a range of angular scales spanning from approximately 1000 to 10 mas (see Table 5). In practice, this means a core with a large fraction of the collecting area in a randomized distribution to provide high snapshot imaging fidelity, symmetric spiral arms extending out to ~40 km baselines, and mid-baseline stations extending asymmetrically out to ~1000 km baselines, filling out the (u , v)-plane with Earth rotation and frequency synthesis.

Title: System Conceptual Design Description	Owner: Selina	Date: 2022-06-06
NRAO Doc. #: 020.10.20.00.00-0005-REP		Version: A

Radius	Collecting Area Fraction	No. of 18m Antennas
0 km < R < 2.2 km	53%	114
2.2 km < R < 20 km	25%	54
20 km < R < 500 km	22%	46

Table 5 - Radial distribution of collecting area in the main array (MA).

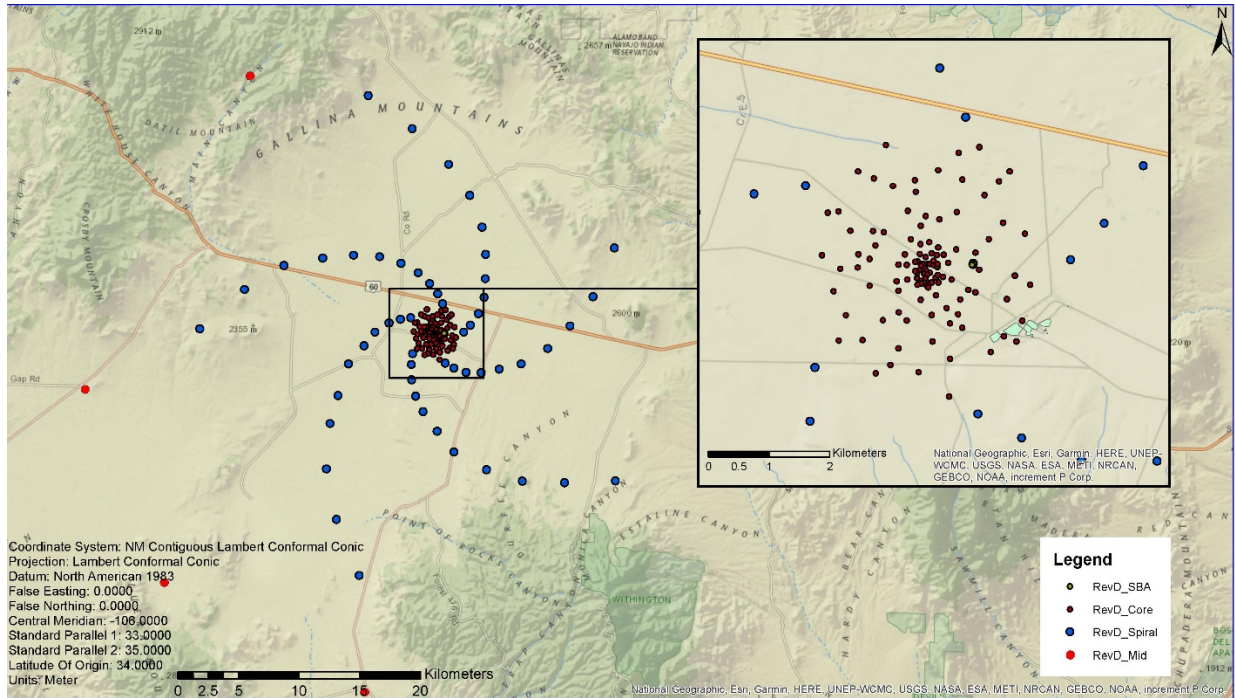

Figure 10 - ngVLA Main Array Configuration Rev. D antenna sites on the Plains of San Agustin. The antenna positions are preliminary but representative for performance quantification and cost estimation. Inset: Zoom view of the compact core. SBA antennas are shown in green.

The array configuration on the plains of San Agustin (Figure 10) is the most developed and characterized. The proposed sites are practical, accounting for investigations of logistical limitations such as land ownership/management, topography and utility availability. These sites also reflect the output of studies of the imaging sensitivity and imaging fidelity of the array. These antenna sites represent a significant fraction of the collecting area, with 168 of the 214 of the main array antenna sites within this area.

The mid-baseline sites also reflect studies of the imaging fidelity and sensitivity, and a preliminary assessment of practical constraints such as topography and utility availability. These sites however are more notional, and should be interpreted as preliminary locations that may be moved up to 10 km¹ through detailed studies of land availability, utility easements and environmental/cultural impact assessments as part of the preliminary and final design development activities.

¹ 10km figure is notional, but is intended to bound the detailed site selection search area. Sites can move up to ±10% of their radial distance from the core with minimal impact on performance. Radial angle from the core can also change by ±3 degrees in the process.

Title: System Conceptual Design Description	Owner: Selina	Date: 2022-06-06
NRAO Doc. #: 020.10.20.00.00-0005-REP		Version: A

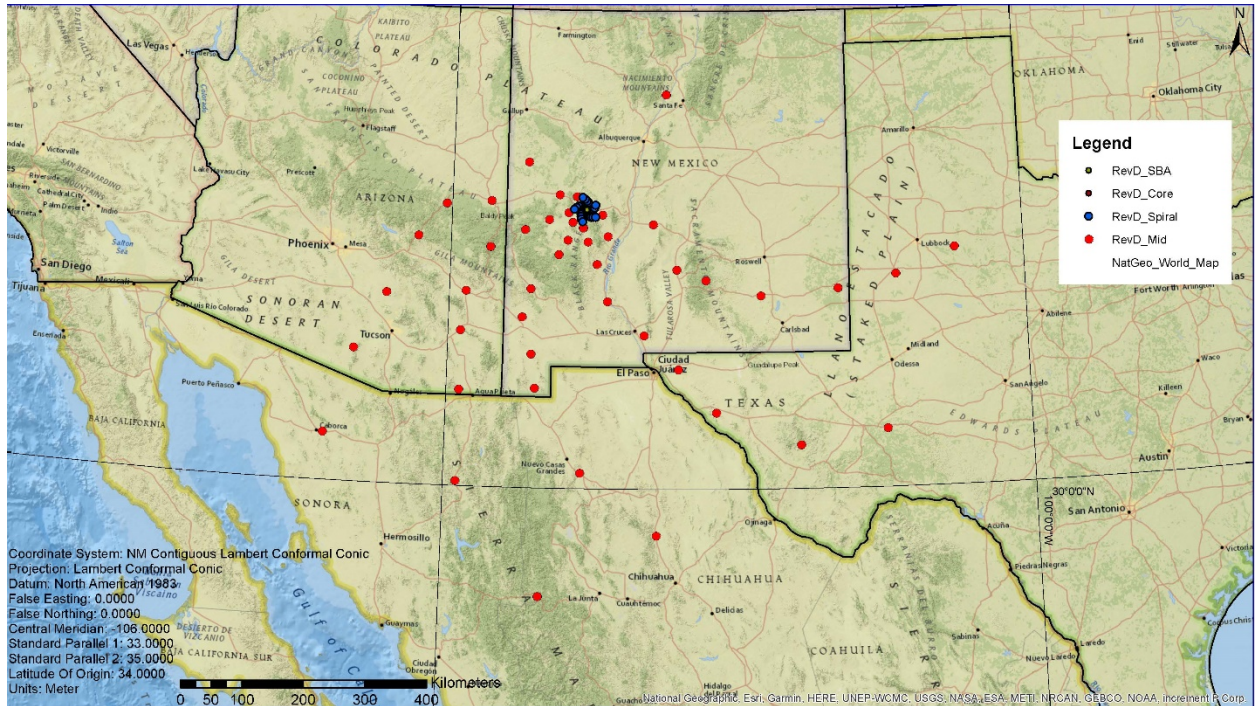

Figure 11 - ngVLA Main Array Configuration Rev D mid-baseline antenna sites in the southwestern US and northern Mexico. These antenna positions are still notional, but are representative for performance quantification and cost estimation.

Over the course of the reference design phase, the design was extended from the main interferometric array to include a long baseline array, a short spacing array, and total power dishes. This was necessary after a review of the key science goals, as these are dependent on the recovery of both small-scale structure requiring continental-scale baselines (KSG5) and large-scale structure that approaches the size of the antenna primary beam (KSG3). Further studies into the imaging fidelity needed for KSG3 confirmed the need for both the short baselines of the SBA along with measurements of total power [RD61].

The short baseline array (SBA) of 19 reflector antennas of 6m aperture will be sensitive to a portion of the larger angular scales undetected by the main array. The SBA will provide antenna spacings from 11 m to 60 m, providing comparable surface brightness sensitivity to the main array, in equal observing time, when the main array is (u, v) -tapered to the natural resolution of the SBA. This allows for commensal observing, along with cross-correlation and cross-calibration of the SBA and main array. The array distribution is semi-randomized to improve the point spread function [RD16]. The SBA will be combined with four 18m (main-array) antennas used in total power (TP) mode to completely fill the central hole in the (u, v) plane left by the 6m dishes. It is a design goal to share the mount design of the 18m interferometric array antennas and the TP antennas, but this will require further study. An initial assessment of the requirements for the total power capability, at the system level, is captured in [AD49].

The long baseline array (Figure 12) consists of 30 18-meter antennas at ten sites. The LBA provides continental scale ($B_{MAX} = 8794$ km) baselines while also providing scales from 100 m to 1000 km within the subarray. This will enable the LBA to function effectively as a stand-alone subarray or integrated with the main array.

Title: System Conceptual Design Description	Owner: Selina	Date: 2022-06-06
NRAO Doc. #: 020.10.20.00.00-0005-REP		Version: A



Figure 12 - View of Main Array and Long Baseline Array stations. Multiple antennas are located at each LBA site.

The preliminary sites of the LBA are summarized in Table 6. The ngVLA array configuration elements are summarized in Table 7.

Antenna	Quantity	Location	Possible Site
	3	Arecibo, Puerto Rico	Arecibo Observatory
	3	St. Croix, US Virgin Islands	VLBA Site
	3	Kauai, HI	Koikee Park Geophysical Observatory
	3	Hawaii, HI	New Site
	3	Hancock, NH	VLBA Site
	3	Green Bank, WV	Green Bank Observatory
	3	Brewster, WA	VLBA Site
	3	Penticton, BC, Canada	Dominion Radio Astrophysical Observatory
	3	North Liberty, IA	VLBA Site
	3	Owens Valley, CA	Owens Valley Radio Observatory

Table 6 - Possible antenna sites and cluster configurations of the ngVLA Long Baseline Array.

Array Element	Aperture	Quantity	B _{MIN}	B _{MAX}	F _{MIN}	F _{MAX}
Long Baseline Array	18m	30	130 km (40 m)	8794 km	1.2 GHz	116 GHz ²
Main Array	18m	214	38 m	1068 km	1.2 GHz	116 GHz ²
Short Baseline Array	6m	19	11 m	60 m	1.2 GHz	116 GHz
Total Power ³	18m	4	-	-	1.2 GHz	116 GHz

Table 7 - Elements within the ngVLA configuration.

² May not extend to 116 GHz at all sites. Sites below 1000 m elevation to operate up to 50 GHz.

³ Included in 214-element main array total. Quantity is TBC.



Title: System Conceptual Design Description	Owner: Selina	Date: 2022-06-06
NRAO Doc. #: 020.10.20.00.00-0005-REP		Version: A

Investigations into sub-array use and imaging algorithms to make the most effective use of the configuration will be an area for investigation in the coming years. Making effective and efficient use of an array that samples such a wide range of angular scales is a key scientific operations challenge on the ngVLA. Dividing the array into sub-arrays with high sensitivity on corresponding scales is expected to improve the observational efficiency for a subset of use cases when existing imaging algorithms are employed. Investigations into different Briggs weighting schemes for specific science applications have also been performed [RD10] as well as research into multi-scale deconvolution algorithms.

7.2 Array Calibration

The current array calibration requirements can be found in [AD15]. The calibration plan and strategies applicable to each observing modes are documented in [AD60, AD59].

- Calibration Requirements, 020.22.00.00.00-0001-REQ
- Observing Mode Calibration Strategies, 020.10.05.05.00-0006-PLA
- Calibration Plan, 020.10.25.00-0006-PLN

Supporting analysis leading up to this strategy can be found in documents:

- Fast Switching Calibration at the ngVLA Site, ngVLA Memo No. 1
- Calibration Strategies for the ngVLA, ngVLA Memo No. 2
- The Concept of a Reference Array for the ngVLA, ngVLA Memo No. 4
- Considerations for a Water Vapor Radiometer System, ngVLA Memo No. 10
- Polarization Calibration with Linearly Polarized Feeds, ngVLA Memo No. 45
- Image Dynamic Range Limits Arising From Visibility Errors, ngVLA Memo No. 60
- Temporal and Spatial Tropospheric Phase Fluctuations at the VLA (and Beyond) and Implications for Phase Calibration, ngVLA Memo No. 61
- Preliminary ngVLA Observing Band Availability Estimate, ngVLA Memo No. 73

The ngVLA calibration strategies are being developed early in the design so that they may guide the design of the hardware, software, and computing elements. The science requirement to deliver high-level data products (calibrated images and cubes) can only be supported with robust and automated system for instrumental and atmospheric calibration. The size and complexity of the calibration and imaging pipeline requires that the system design be responsive to its needs, and it should drive the design where possible.

A secondary concern is the efficiency of the calibration process. Algorithms used must be suitable for parallel processing, antennas must not require much individual attention, and minimal human intervention should be needed for operation. The calibration overheads applied will vary with the science requirements of a given observation, and less rigorous (and computationally or time efficient) calibration approaches will be applied when possible. In general, a set of normal calibration strategies will be applicable to the standard observing modes and automatically generated high-level data products, with more advanced strategies reserved for cases where the greatest possible accuracy is required.

The Operations Concept [AD08] calls for guaranteed time on source to each observer, with calibration overheads being the responsibility of the facility. Making the calibration strategy an Observatory function enables reuse of calibration observations for adjacent observations when their requirements are sufficiently similar, further improving observation efficiency. The general calibration strategies under consideration for high-level data product generation are summarized below.

Fast Atmospheric Phase Calibration: Rapid atmospheric phase fluctuations will be mitigated by a combination of relative water vapor radiometry (WVR) and antenna switching cycles to astronomical phase calibrators. The switching cycle time will depend on empirical validation of the strategy, but is expected to be necessary on one to ten minute scales. The antenna is designed to both house the WVR



Title: System Conceptual Design Description	Owner: Selina	Date: 2022-06-06
NRAO Doc. #: 020.10.20.00.00-0005-REP		Version: A

and enable fast switching cycles. The latter calls for moving 3° on sky and to settle within the pointing specification within 7 seconds of time for elevation angles $<70^\circ$ [AD17].

Slow Atmospheric & Electronic Phase/Delay and Amplitude Calibration: Slow atmospheric and electronic phase/delay calibration will be achieved by traditional approaches, with astronomical complex gain (amplitude and phase) calibrator observations bracketing all observations. Several astronomical calibrators may be used to map the slow varying terms, and mapping ionospheric fluctuations may require observations at multiple frequencies.

An extensive grid of sources will be required for phase and amplitude calibration. A list of known astronomical amplitude calibrators will be used to correct for system gain fluctuations within and between observations taken over an extended period of time. The large range of baselines present on the ngVLA means that it cannot be assumed that the source is unresolved at all scales, and the calibrators themselves must be imaged before use in the calibration process. The calibration database will maintain a history of recent solutions to enable look-up of prior values. Amplitude calibration on intermediate time scales will be monitored with a switched power system injected before the first LNA.

Bandpass Calibration: The number of setups in the analog portions of the system will be limited, so typical calibration can correct for analog bandpass effects based on historical lookup tables that are updated as the configuration of the system changes (when an antenna is serviced). This will be performed routinely for sideband separation of the quadrature mixers. When required, bandpass calibration observations can also calibrate the sideband rejection of the quadrature mixers and for the bandpass shape of the cryogenic receivers.

Polarization Calibration: The use of linear feeds will require polarization calibration for most observations. Differences in parallactic angle across the array extent lead to feed rotation, so a single observation of a point source may solve simultaneously for the polarization leakage terms and the source polarization. Calibration for polarization as a function of position within the antenna beam will be assumed to be time invariant and corrected based on look-up models or maps of the primary beams. The noise diode injection system will be coherent between an antennas polarization pairs, enabling automated measurement of any fluctuations in phase/delay between an antennas polarization pairs between astronomical polarization calibration observations.

Relative Flux Calibration: This calibration is used to tie together observations of a source taken over an extended period. The system will model the atmospheric opacity dry term based on barometric pressure and temperature monitored at the array core and each outlying station. The wet term may be derived from the WVRs, solving for precipitable water vapor (PWV) at zenith for each site. The WVR measurements may be augmented or replaced by a dedicated tipping radiometer at the array core and at key outlying stations. A temperature stabilized noise diode will provide a power reference, and when combined with corrections for modeled atmospheric opacity, a constant ratio in power from the switched noise calibrator and the source is assumed. Alternatively, an astronomical flux calibrator may be used when required to achieve the requisite imaging dynamic range.

7.3 Antennas

7.3.1 18m Antennas

The requirements and supporting conceptual design (both optical and mechanical) of the 18m antennas are described in the following documents [AD17–21]:

- ngVLA Antenna: Technical Requirements, 020.25.00.00.00-0001-REQ
- ngVLA Antenna Optical Definition, 020.25.01.00.00-0006-DSN
- ngVLA Antenna: Optical Design, EA-NGV-DR-05

Title: System Conceptual Design Description	Owner: Selina	Date: 2022-06-06
NRAO Doc. #: 020.10.20.00.00-0005-REP		Version: A

- ngVLA Antenna: Design Description, 1021006-REP-21-000000-0001

Supporting analysis leading up to this design can be found in the following documents [RD16, 26–28,48,49]:

- ngVLA Technical Study Offset Gregorian Antenna, ngVLA Memo No. 26
- Exploration of Suitable Mounts for a 15m Offset Antenna, ngVLA Memo No. 25
- Various Suitable Mounts for an 18m Antenna, ngVLA Memo No. 27
- The ngVLA Short Baseline Array, ngVLA Memo No. 43
- System-level Cost Comparison of Offset and Symmetric Optics, ngVLA Antenna Memo No. 1
- System-level Evaluation of Aperture Size, ngVLA Antenna Memo No. 2
- Antenna Optical Design Alternatives, ngVLA Antenna Memo No. 3
- Efficiency Loss and Pointing Offsets Due to Feed Offsets on the ngVLA Reference Design Antenna, ngVLA Antenna Memo No. 8
- Practical Limits to Axis Offsets, ngVLA Antenna Memo No. 9

The ngVLA project has invested significant development effort into the antenna optical and mechanical design as part of the facility development effort to understand the available parameter space and likely performance and cost of this system element. A total of five supporting concepts were developed prior to selecting the conceptual design of the 18m antenna. These additional designs (three shown in Figure 13) are documented in a series of proposals and technical reports that are available upon request.

After an extensive and competitive procurement process, NRAO selected the concept proposed by mtex antenna technology gmbh (Figure 14). A detailed statement of work [RD68] defines the design activities for the preliminary design, prototype and final design phase of this contract. The design is presently advancing towards a subsystem PDR in Q4 2022, with ngVLA effort largely focused on defining the interfacing systems to sufficient degree to enable this level of design. A preliminary ICD has been prepared for the antenna electronics systems, and requirements have been established for the Monitor and Control ICD (vendor provided) consistent with the proposed MCL system concept and protocols. The selected optical and mechanical design of the antenna is summarized in this section.

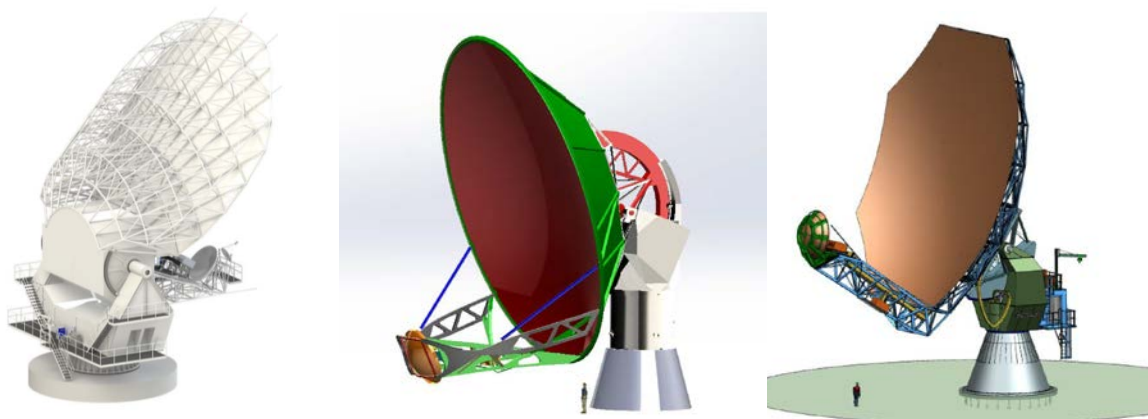

Figure 13 – Additional ngVLA Antenna Concepts. Left: CPI/Vertex Antennentechnik, Center: Calian Technologies/NRCC, Right: OHB/MT Mechatronics.

Title: System Conceptual Design Description	Owner: Selina	Date: 2022-06-06
NRAO Doc. #: 020.10.20.00.00-0005-REP		Version: A

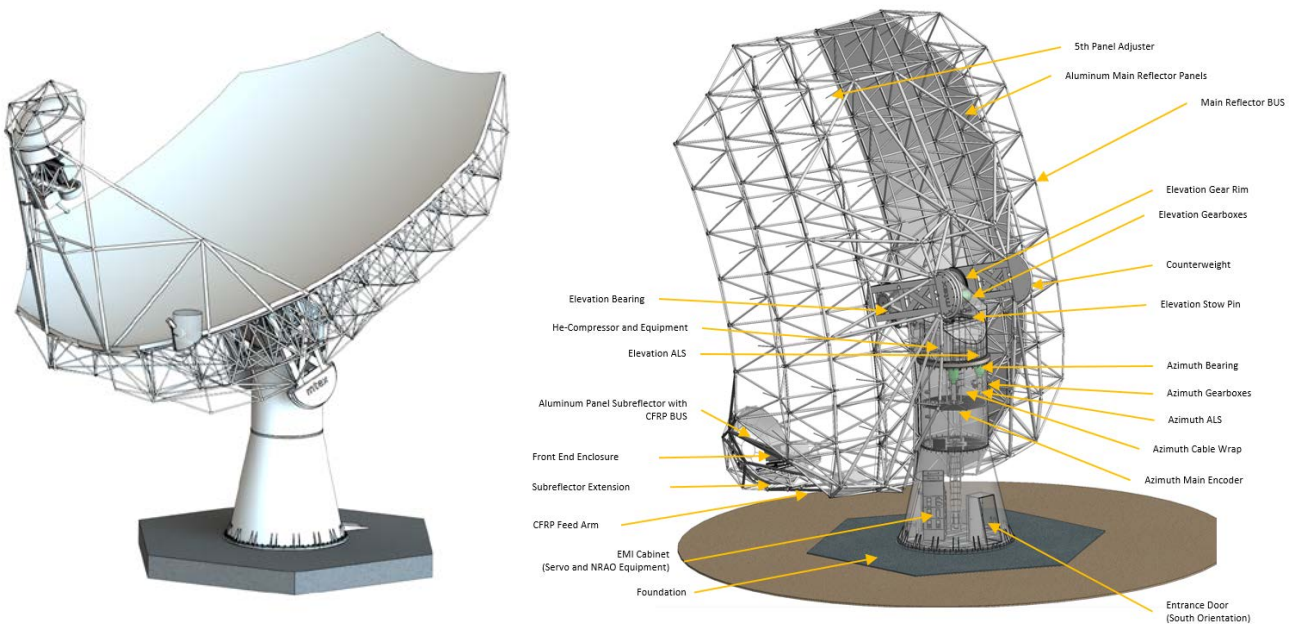

Figure 14 – Selected conceptual design of the 18m antenna, courtesy of mtex antenna technology gmbh.

As described in Section 7.1, the array conceptual design includes an 18-meter aperture antenna in the main array and long baseline array, and a 6-meter aperture antenna in the short baseline array.

The 18m antenna concept strikes a balance between competing science requirements and the programmatic targets for lifecycle cost. Sensitivity goals will be met by the total effective collecting area of the array. The conceptual design includes 244 antennas of 18m aperture (MA and LBA) using an offset Gregorian unblocked optical design [AD18] with shaped reflectors to improve illumination efficiency.

The optimization for operations and construction cost suggests that a smaller number of larger apertures (~20–22m) is preferable to larger numbers of small apertures. Survey speed and imaging fidelity requirements push the opposite direction, and a compromise value of 18m diameter was adopted for the conceptual design considering point source sensitivity, survey speed and imaging fidelity metrics [RD49].

The inclusion of frequencies down to 1.2 GHz when combined with the operational cost targets significantly constrains the optical configuration. The use of feeds with wide illumination angles decreases their size such that they can be mounted within shared cryostats. This choice constrains the secondary angle of illumination to a degree that only Gregorian optical designs are practical. [RD65] However, with a science priority of high imaging dynamic range in the 10–50 GHz frequency range, an offset Gregorian is near optimal due to no blockage, limited scatter and low sidelobe levels [RD65]. System-level lifecycle cost analysis also suggest this choice is optimal [RD48]. The unblocked aperture will minimize scattering, spillover and sidelobe pickup, minimizing the number of antennas necessary to reach sensitivity targets. Maintenance requirements favor antenna optical configurations where the feed support arm is on the “low side” of the reflector. This can yield the lowest spillover temperature (averaged over the full range of elevation) when combined with a ground spillover shield [AD16].

The design aims for Ruze surface performance to 116 GHz, with a surface accuracy of 160 $\mu\text{m rms}$ ($\lambda/16$ @116 GHz) for the primary and subreflector combined under precision environmental conditions. The antenna optics are optimized for performance above 5 GHz with some degradation in performance accepted at the lowest frequencies due to diffraction, in exchange for more stiffness in the feed arm to improve pointing performance.

Title: System Conceptual Design Description	Owner: Selina	Date: 2022-06-06
NRAO Doc. #: 020.10.20.00.00-0005-REP		Version: A

Since the ngVLA is envisioned as a general purpose, proposal-driven, pointed instrument (rather than a dedicated survey telescope), the optics will be shaped to optimize the illumination pattern of single pixel feeds, increasing antenna gain while minimizing spillover to ground. The optical design has been refined based on feedback from the mechanical antenna designers and then optimized to maximize the ratio of gain to system temperature at 30 GHz, averaged over the full range of elevation, using the using the Band 4 feed (common design to all bands above 12 GHz, when scaled by frequency) patterns [AD16]. The design has a 3.2m diameter subreflector with a 55° half angle and a 40° extension to reduce ground noise pickup (Figure 15).

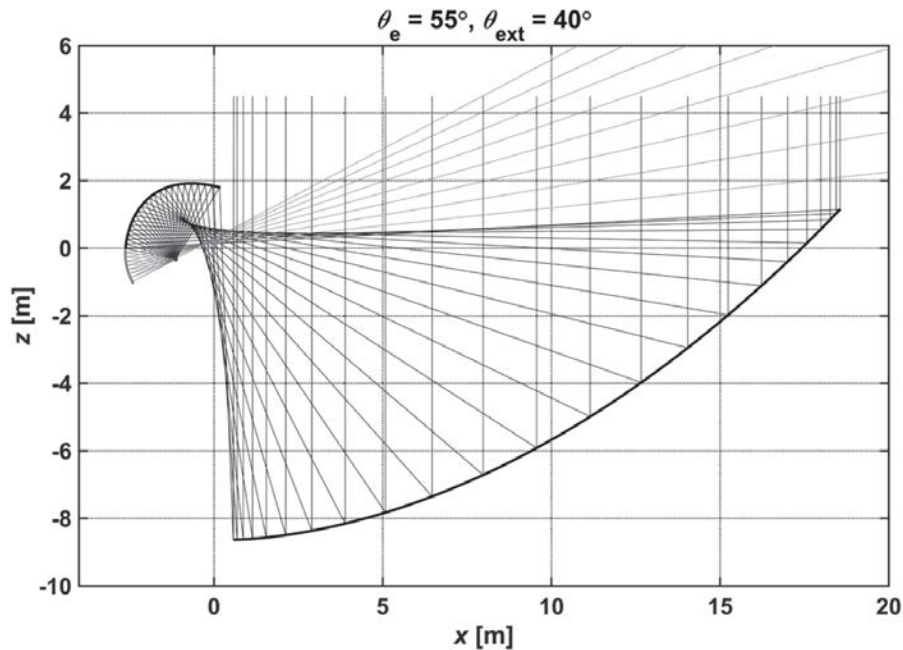

Figure 15 - Optical baseline design that will be used for the antenna preliminary design and prototype.

The mechanical design is informed by the key requirements for pointing precision, surface accuracy, and path length delay stability. The selected mechanical concept employs a conventional altitude-azimuth pedestal design with gearbox drive servo motors. Initial studies suggest pedestal designs are expected to have lower lifecycle cost while meeting the pointing specifications, and the preferred design minimizes the pedestal height and axis offsets while providing a large 3m diameter azimuth bearing for stiffness. In the precision operating conditions, the mount is expected to support 18" all-sky pointing and 3" referenced/offset pointing.

The backup structure and panel design are optimized for manufacturability while supporting the surface accuracy requirements. ngVLA requirements, in support of 116 GHz operation, lie at the limits of what is achievable by stretch formed panels, so the design employs a novel reinforced and post machined aluminum panel design. The panel surface is machined from aluminum billet, first by machining the backside of the surface. A radial reinforcing truss structure is then bolted and epoxied in place, reducing the total machine volume. With the reinforcing structure in place, the panel is then flipped and the front face is machined to the final surface profile. An Initial prototype employing this manufacturing technique has 16 μ m rms surface error, a factor of three better than required in the surface error budget.

The primarily rectangular panel design leads to the octagonal main reflector (subtending the 18m circular aperture) and a tetrahedral backup structure (Figure 14). 5-point panel mounts are used based on an analysis of the solar radiation load on the antennas during the daytime (normal operating) conditions. This mount design will also mitigate thermal deformation at nighttime caused by ground thermal emission

Title: System Conceptual Design Description	Owner: Selina	Date: 2022-06-06
NRAO Doc. #: 020.10.20.00.00-0005-REP		Version: A

combined with panel surface emission to cold sky. The backup structure consists of tubes and nodes with bolted connections. Engraved interfaces on each tube and node permit easy verification of correct assembly, and the backup structure component manufacturing tolerances are sufficiently strict that no shimming or alignment is required in the backup structure (adjustment is limited to be between the backup structure and panel).

7.3.2 6m Short Baseline Array Antennas

The requirements and a supporting conceptual design of the 6m short baseline array antennas are described in the following documents:

- ngVLA Short Baseline Array Antenna: Technical Requirements, 020.47.05.00.00-0001-REQ
- ngVLA Short Baseline Array Antenna: Conceptual Design, ngVLA6-0000-002-CDD-002

Supporting analysis leading up to this design can be found in the following documents [RD 16, 26–28,48,49]:

- The ngVLA Short Baseline Array, ngVLA Memo No. 43
- Demonstration & Analysis of ngVLA core + Short Baseline Array Extended Structure Imaging v2, ngVLA Memo No. 67
- SBA Antenna Pointing Specification for the Conceptual Design, ngVLA Antenna Memo No. 11

As described in Section 7.1, the array conceptual design includes 19 antennas of 6m aperture. The design uses an offset Gregorian optical design with shared parameters and interfaces with the front end equipment such that feeds, receivers and other antenna electronics are interchangeable between the two arrays.

The 6m optical design is preliminary, and is expected to be improved with a ground spillover shield / subreflector extension as was implemented on the 18m design. The reflector shaping will also be revised to account for the selected shaping of the 18m design as part of the preliminary design phase activities.

The mechanical design of the antenna differs significantly from the 18m design due to a key requirement for the short baseline array – the need for close packing of the antennas to produce the shortest 11m baselines. The combination of close packing with the offset Gregorian geometry leads to a design where the elevation axis must be as close to the edge of the main reflector as practical (Figure 16).

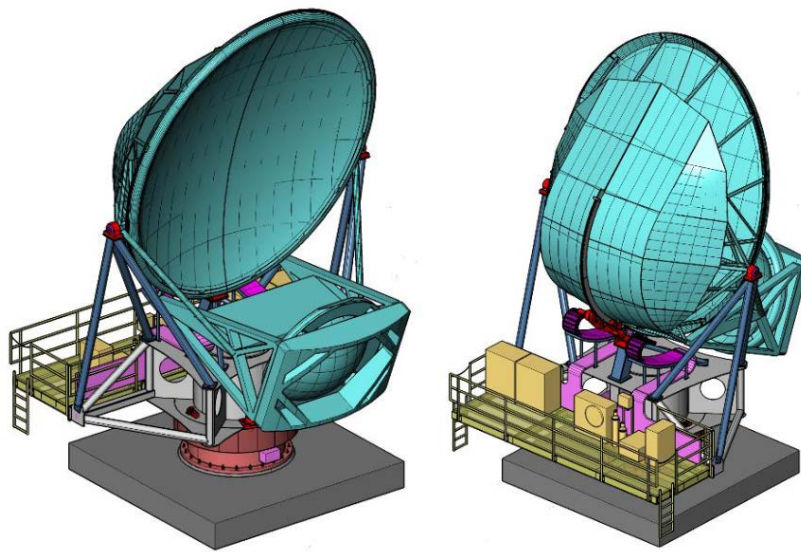

Figure 16 - NRCC conceptual design of the 6m short baseline array antenna.



Title: System Conceptual Design Description	Owner: Selina	Date: 2022-06-06
NRAO Doc. #: 020.10.20.00.00-0005-REP		Version: A

The conceptual design presented as part of this system design was developed by NRCC as an in-kind contribution to the project. NRCC has elected not to pursue the preliminary design and to refocus their ngVLA contributions into other system elements, so the details of this design should be considered notional today and subject to revision when the preliminary design of the system is advanced (likely on contract in response to an RFP) in FY23. However, the identified design constraints and their impact on the mechanical concept for the 6m antenna are key findings that are expected to endure through subsequent design iterations.

7.4 Antenna Electronics

7.4.1 Front End

The Front End system requirements and supporting conceptual design are described in the following documents [AD22–23]:

- ngVLA Front End: Technical Requirements, 020.30.05.00.00-0003-REQ
- ngVLA Front End: Conceptual Design, 020.30.05.00.00-0006-DSN
- Receiver Cascaded Analysis Tool, 020.30.05.00.00-0004-GEN

The ngVLA will provide continuous frequency coverage from 1.2–50.5 GHz and 70–116 GHz in multiple bands. Receivers will be cryogenically cooled, with the receiver cryostats designed to integrate multiple receiver bands to the extent possible. Limiting the number of cryostats and receivers is desired to reduce the construction, maintenance and electrical power costs.

The total number of bands required strongly depends on their fractional bandwidths. This is especially important in the lower decade of frequency coverage given the size and mass of the lower frequency feeds and cryostats. The ngVLA Front End concept accepts a penalty in sensitivity below 12 GHz to reduce the total band count while spanning the required frequency range.

The conceptual design receiver configuration consists of the low-frequency Band 1 receiver (1.2–3.5 GHz) in one cryostat, and five receivers spanning from 3.4 to 116 GHz in a second cryostat. Bands 1 and 2 employ wideband quad-ridged feed horns (QRFHs) and wideband LNAs, each covering L+S bands and C+X bands respectively (Table 8). The Band 1 conceptual design is all metal, while dielectric loading is used in Band 2 to improve illumination efficiency over frequency. The Band 1 feed is cooled to 80K while the Band 2 feed is cooled to 20K behind a thermal gap, and calibration couplers and LNAs are cooled to 20K for both bands.

Band #	Cryostat	f_L GHz	f_M GHz	f_H GHz	$f_H:f_L$	BW GHz	Output Type		Output Pol.
							OMT	Cryostat	
1	A	1.2	2.0	3.5	2.92	2.3	SMA	SMA	Linear
2	B	3.4	6.5	12.3	3.62	8.9	SMA	SMA	Linear
3	B	12.3	15.9	20.5	1.67	8.2	WR56.3	SMA	Linear
4	B	20.5	26.4	34	1.66	13.5	WR34	2.92mm	Linear
5	B	30.5	39.2	50.5	1.66	20	WR22	WR22	Linear
6	B	70	90	116	1.66	46	WR10	WR10	Linear

Table 8 - Key parameters of the baseline receiver configuration.

The four high-frequency bands (12.3–116 GHz) employ waveguide-bandwidth (~1.67:1) axially corrugated feed horns (ACFHs) and LNAs for optimum aperture efficiency and noise performance. The axially corrugated feed horns with a circular waveguide output ensure uniform illumination over frequency, with



Title: System Conceptual Design Description	Owner: Selina	Date: 2022-06-06
NRAO Doc. #: 020.10.20.00.00-0005-REP		Version: A

minimum spillover and resistive loss. The compact nature of the wide-angle feed horns enables the entire feed, OMT and LNA assembly to be cooled to 20K, reducing total noise.

All six receivers are linearly polarized. Each includes a calibration noise injection port upstream of the LNAs, coherent across polarizations for relative phase/delay calibration, with variable output power to accommodate a range of antenna temperatures in support of solar observations. Coaxial outputs are favored at lower frequencies for serviceability, while rectangular waveguides are employed for Band 5 and 6 to minimize the gain slope. Each receiver is packaged into one of two standard cartridge designs, enabling the interchange of receivers for service.

Key characteristics of the 6-band receiver concept are shown in Table 8. Figure 17 shows the expected receiver noise temperature from the cascaded analysis tool [AD28]. Figure 18 shows the system temperature at 45-degrees in elevation with 6mm of PWV.

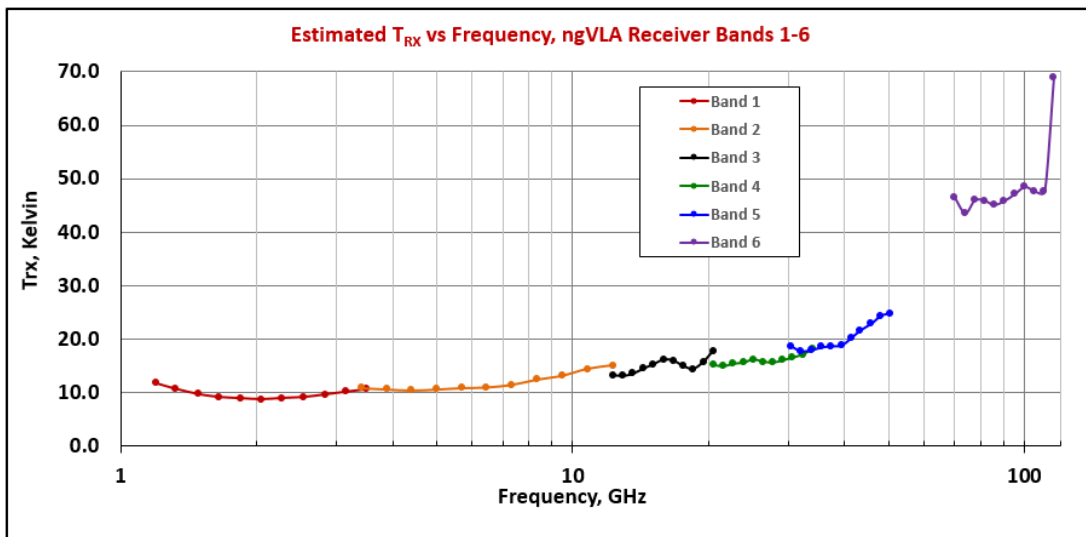

Figure 17 - Receiver Temperature for the ngVLA 6-band receiver concept.

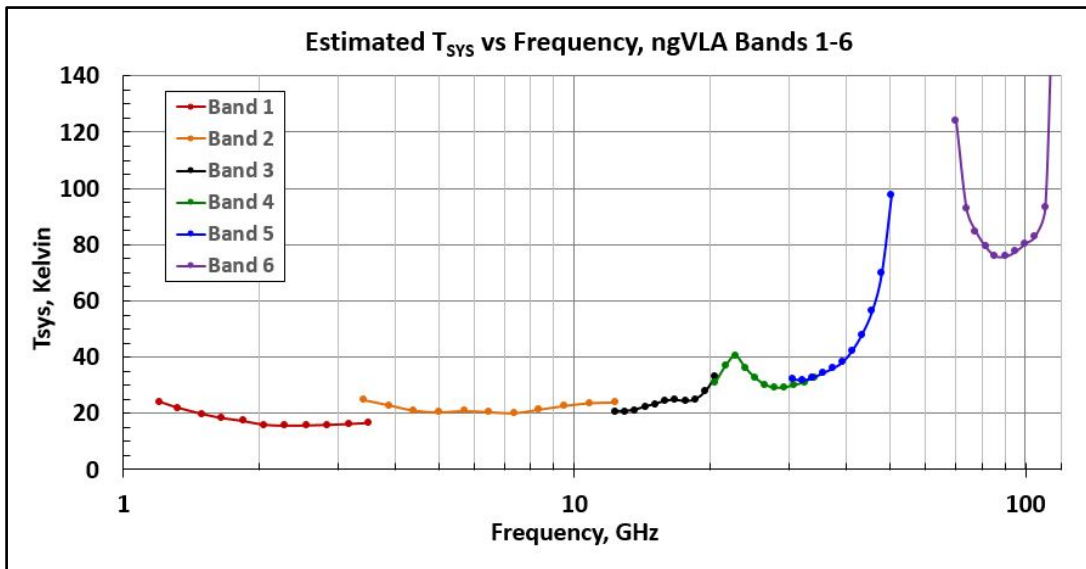

Figure 18 - System temperature for the ngVLA 6-band receiver configuration.

Title: System Conceptual Design Description	Owner: Selina	Date: 2022-06-06
NRAO Doc. #: 020.10.20.00.00-0005-REP		Version: A

7.4.2 Cryogenic System

The requirements and supporting conceptual design of the cryogenic system are described in [AD24–25]:

- ngVLA Cryogenic System: Technical Requirements, 020.30.10.00.00-0001-REQ
- ngVLA Cryogenic System: Conceptual Design Description, 020.30.10.00.00-0007-DSN

Supporting analysis leading up to this design can be found in:

- Advanced Cryocoolers for Next Generation VLA, ngVLA Memo No. 24.
- Advanced Stirling Pulse Tube Cryocooler and Variable Speed Gifford McMahon Cryocooler Trade Study, ngVLA Electronics Memo No. 3
- Thermoacoustic Stirling Cryocooler and Variable Speed Gifford McMahon Cryocooler Trade Study No. 2, ngVLA Electronics Memo No. 12.
- Cryogenics Development Plan, 020.30.10.00.00-0006-PLA
- Cryogenics Concept Selection, 020.30.10.00.00-0009-REP

The performance requirements for the cryogenics are driven by the Front End concept [AD23] and by maintenance and power efficiency requirements established for the project [AD02, AD03]. It has been emphasized that for the ngVLA project to be viable, the annual operation cost should not exceed the current VLA and VLBA budget by more than a factor of three. This is quite challenging considering that the project is aiming for nine times the number of antennas.

To meet the programmatic requirements, the number of cryostats per antenna has been reduced to two (housing six receivers total), reducing the preventative maintenance effort, corrective maintenance effort, and power consumption per antenna (see Figure 19). Various cryogenic cycles and refrigerator concepts were explored and a two-stage Gifford-McMahon design was selected for the conceptual design baseline. While other cooling cycles (such as the Stirling cycle) look attractive, the GM system was selected based on a combination of the technical maturity of the system components, the thermal stability, cooling capacity, and relative construction cost. Additional operational and maintenance savings may be possible with a Stirling cycle two-stage pulse-tube system, but such a system is not commercially available to ngVLA requirements and presents a significant development risk. While the GM system has been selected, a thermos-acoustic Stirling cycle system development effort will proceed in parallel through to the preliminary design review to see if this system merits a change to the design baseline in the future. [AD55, RD72]

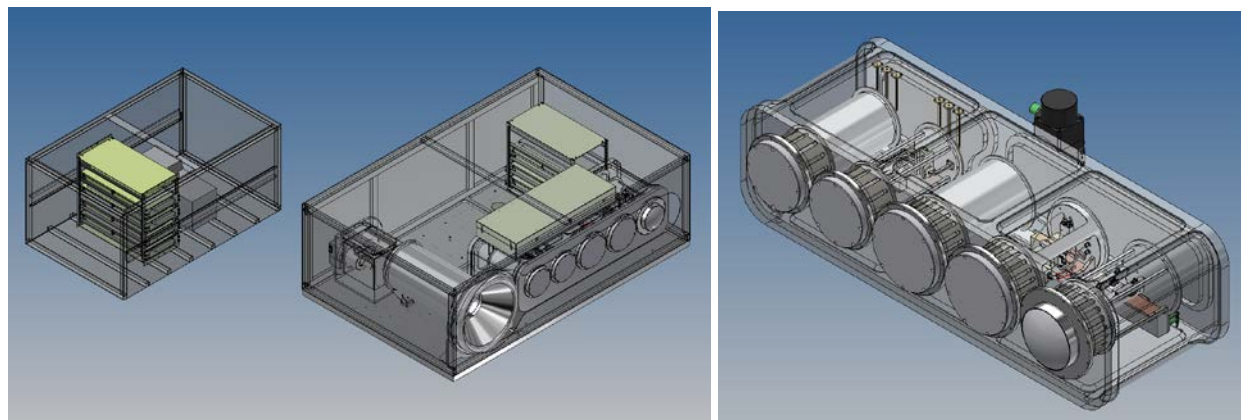

Figure 19 - Left: Front End component packaging at the antenna secondary focus. Band selection and focus are achieved with a dual-axis translation stage. Integrated receiver packages are located in close proximity to cryostats, minimizing the analog signal path length (Section 7.4.3). Right: Bands 2-6 are housed within a single cryostat.

Title: System Conceptual Design Description	Owner: Selina	Date: 2022-06-06
NRAO Doc. #: 020.10.20.00.00-0005-REP		Version: A

The conceptual design employs two dual-stage refrigerators and a single scroll compressor (Figure 20). Both the refrigerators and compressor are equipped with variable frequency drives (VFDs) for adjustable cooling capacity. Having the capability to adjust the cooling power allows us to match supply and demand, minimize the power consumption, and lengthen the preventive maintenance cycle by reducing the wear on the refrigerator seals, which is proportional to the operating speed.

The cryogenic system design also includes the vacuum roughing pumps required to cool the refrigerators from room temperature. Due to the feedback loops required to effectively control the VFD system, the design is integrated with both the Front End and the Monitor and Control system. The major elements of the cryogenic system are summarized in Figure 20.

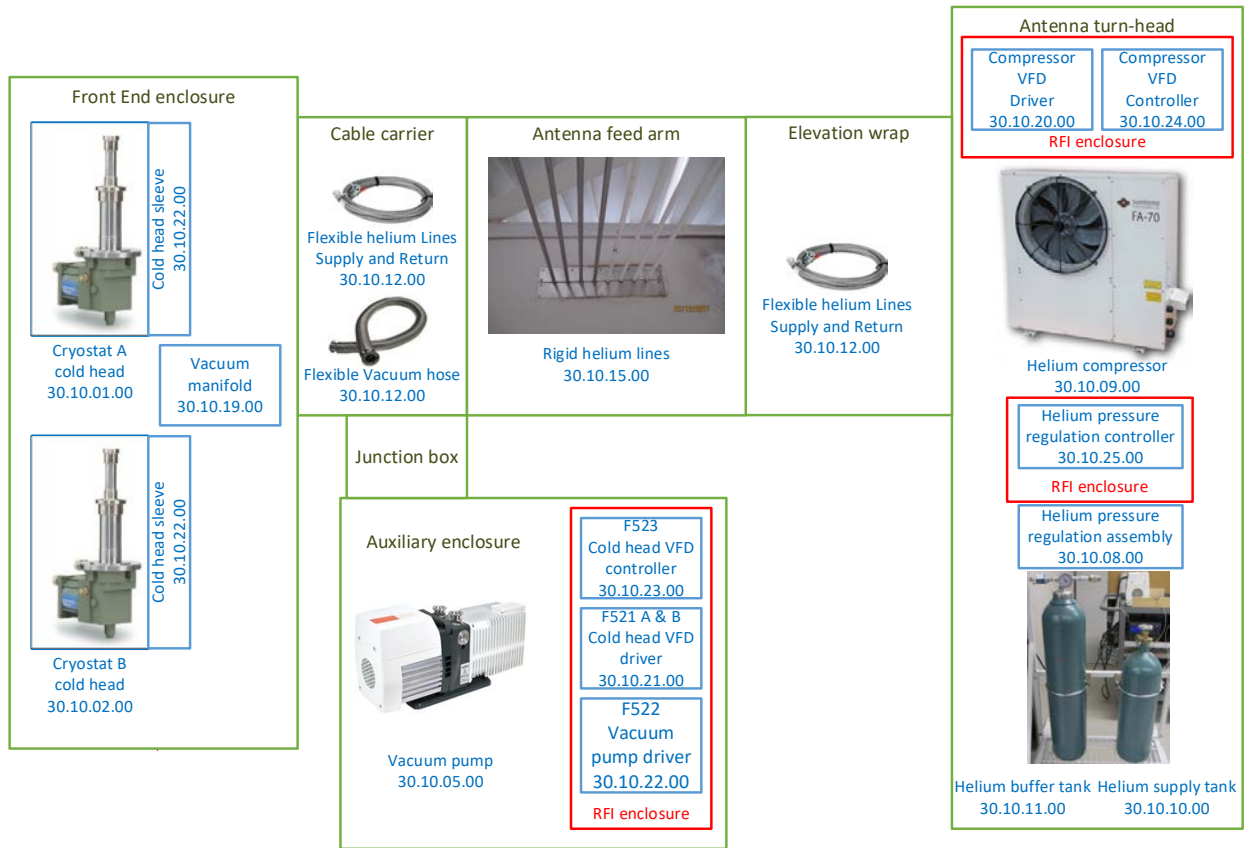

Figure 20 - Cryogenic system block diagram. Part numbers within the product breakdown structure are also given [AD25].

The preferred compressor configuration for the 18m antenna is liquid cooled, as the compressor will reside within the antenna turnhead. Representative parts are the Sumitomo F40-H and Oxford Cryosystems K450. The refrigerators would be equivalent to a Trillium 350CS, with multiple candidates identified in the conceptual design report [AD25]. A dual sleeve may be used on the cold head to facilitate refrigerator replacement, eliminating the need to flush the newly installed cold head with helium to remove trapped air, and eliminating the risk of damaging a seal during service.

7.4.3 Integrated Down Converters & Digitizers

The requirements and supporting conceptual design of the integrated downconverter digitizer system are described in the following documents [AD26–27]:

Title: System Conceptual Design Description	Owner: Selina	Date: 2022-06-06
NRAO Doc. #: 020.10.20.00.00-0005-REP		Version: A

- Integrated Receivers and Digitizers: Technical Specifications, 020.30.15.00.00-0003-REQ
- Integrated Receivers and Digitizers: Design Description, 020.30.15.00.00-0004-DSN

Supporting analysis leading up to this design can be found in:

- Downconversion and Digitization Methodology for the ngVLA, ngVLA Electronics Memo No. 1
- An Integrated Receiver Concept for the ngVLA, ngVLA Memo No. 29.
- Headroom, Dynamic Range, and Quantization Considerations, ngVLA Electronics Memo No. 8

The role of the Integrated Receiver and Digitizer (IRD) packages [AD27] is to further amplify signals provided by the cryogenic front end, downconvert them where necessary, digitize them, and deliver the resultant data streams by optical fiber to a moderately remote collection point from the focal plane (typically in the antenna pedestal). Here the digital data streams are formatted and time-stamped before being launched onto a more conventional network for transmission back to the central signal processor. Interfaces are needed to provide for the synchronization of local oscillators (LOs) and sample clocks, power leveling, command and control, health and performance monitoring, and diagnostics for troubleshooting in the event of component failure.

A fundamental conceptual choice for ngVLA was to digitize as close to the analog receiver front end as possible, with a minimum number of intervening RF switches (ideally none) and components for reliability and gain stability. Digitizing the full band of each receiver, with a minimum variation in analog system setup was highly desirable for ensuring data product reuse and enabling robust polarization and bandpass calibration pipeline automation.

This combination of goals strongly favors an integrated approach to downconversion and digitization, with a high degree of parallelization. Integrated approaches and connectorized components lead to different downconverter architectures, and the details of this trade are reflected in the preferred architecture for the IRD packages.

This IRD subsystem consists of direct-sampled (DS) and sideband-separating modules (2SB, Figure 21) for all telescope bands, which include warm amplification, filtering, power leveling, analog-to-digital conversion, and fiber-optic transmission, as well as external splitters and combiners as needed to feed them from the cryogenic signal paths. Cryogenic systems and thermal transitions, as well as front-end cabling, waveguide runs, and fiber-optic signal paths outside the IRD modules themselves are outside the scope of this work package, though the interfaces must be considered.

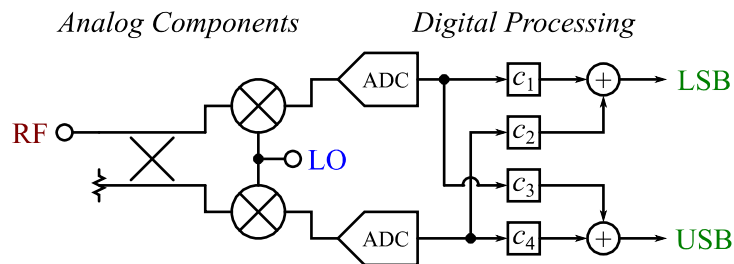

Figure 21 – A sideband-separating mixer with a numerically implemented IF quadrature hybrid using calibrated complex-gain coefficients. Details are conceptual only. The hybrid will be replaced by a 90-degree phase shift on the quadrature LO in the ngVLA implementation, and the complex gain coefficients for sideband separation are implemented in the DBE.

The frequency plan for the conceptual design is shown in Figure 22 and Table 9 [AD27]. The band 1 receiver is directly sampled by a single module, while all other bands are spanned by parallel IRD modules. Each LO is a harmonic of 2.9 GHz, while the digitizers are clocked at 7 Gsps, providing overlapping coverage at the module band edges, after accounting for the roll off in the anti-alias filters. The IRD

Title: System Conceptual Design Description	Owner: Selina	Date: 2022-06-06
NRAO Doc. #: 020.10.20.00.00-0005-REP		Version: A

modules are located in the front end enclosure, adjacent to the cryostats on the antenna feed arm, as shown in Figure 19. 8-bit digitization is used at all bands in support of the dynamic range requirements and to provide sufficient immunity to Radio Frequency Interference [RD76].

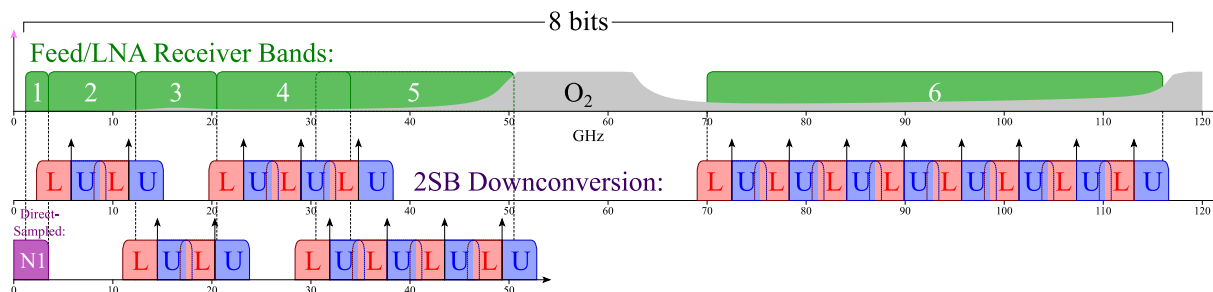

Figure 22 – downconverter-digitizer concept employing integrated receiver technology for both direct and dual sideband converter/samplers. Nyquist zone I is direct sampled single-sideband at 8 bits for Band 1. From 3.4 GHz to 50 GHz and from 70 GHz to 116 GHz the system uses single-stage down conversion to baseband and IQ sampling at 8 bits. The LOs are arranged as multiples of 2.9 GHz, while the sampler clocks run at 7 Gps, providing overlapping bandwidth at the band edges to support calibration and maintain within the bandpass flatness, aliased-frequency content, and quantization efficiency specifications.

Band	RF Range (GHz)	Type	# bits	Sample Rate (GS/s)	LO (GHz)	LSB (GHz)	USB (GHz)
1	1.2–3.5	DS	8	7	--	0.0–3.3	
2	3.5–12.3	2SB	8	7	5.8	2.9–5.8	5.8–8.7
		2SB	8	7	11.6	8.7–11.6	11.6–14.5
3	12.3–20.5	2SB	8	7	14.5	11.6–14.5	14.5–17.4
		2SB	8	7	20.3	17.4–20.3	20.3–23.2
4	20.5–34	2SB	8	7	23.2	20.3–23.2	23.2–26.1
		2SB	8	7	29.0	26.1–29.0	29.0–31.9
		2SB	8	7	34.8	31.9–34.8	34.8–37.7
5	30.5–50.5	2SB	8	7	31.9	29.0–31.9	31.9–34.8
		2SB	8	7	37.7	34.8–37.7	37.7–40.6
		2SB	8	7	43.5	40.6–43.5	43.5–46.4
		2SB	8	7	49.3	46.4–49.3	49.3–52.2
6	70–116	2SB	8	7	72.5	69.6–72.5	72.5–75.4
		2SB	8	7	78.3	75.4–78.3	78.3–81.2
		2SB	8	7	84.1	81.2–84.1	84.1–87.0
		2SB	8	7	89.9	87.0–89.9	89.9–92.8
		2SB	8	7	95.7	92.8–95.7	95.7–98.6
		2SB	8	7	101.5	98.6–101.5	101.5–104.4
		2SB	8	7	107.3	104.4–107.3	107.3–110.2
		2SB	8	7	113.1	110.2–113.1	113.1–116.0

Table 9 - IRD frequency plan in tabular form.



Title: System Conceptual Design Description	Owner: Selina	Date: 2022-06-06
NRAO Doc. #: 020.10.20.00.00-0005-REP		Version: A

The design of the ngVLA IRD modules evolved from an internal research program (the Integrated Receiver Development program), which has been developing the techniques used in their construction for more than a decade. The original program aimed to leverage the advantages of modern electronic integration and digital signal processing, to digitize as closely to the antenna feed-point as possible without compromising the ultimate performance, and to re-optimize legacy receiver architectures in light of these new techniques and in anticipation of future telescope facilities such as the ngVLA.

Integration and digital signal processing (DSP) are deemed complementary in this program, in that the latter provides for greater signal fidelity and precision in concert with detailed calibrations compared to purely analog techniques, while the former guarantees the long-term stability and uniformity of those calibrations. This results also in compact, low-power, replaceable receiver units which are a good fit for ngVLA's maintenance and operability requirements. The compact form factor is also complementary with the ngVLA Offset Gregorian antenna concept, which imposes constraints on the mass and volume of the electronics at the secondary focus of the antenna.

7.4.4 Digital Back End (DBE)

While located within the antenna, as an element of the digital processing system we consider the DBE part of the Central Signal Processor to ensure a complete and logical functional allocation between the various elements of the digital signal processing chain. The requirements and supporting conceptual design of the digital back end and data transmission system are described in the following documents [AD28–29]:

- Central Signal Processor: Technical Specifications, 020.40.00.00.00-0001-REQ
- Central Signal Processor: Design Description, 020.40.00.00.00-0005-DSN

The ngVLA digital back end (DBE) is responsible for four critical functions. First, it must ingest the data stream from the integrated receiver digitizer and align it with a known timing reference. Second, it must perform the digital sideband separation to remove the image band in the I-Q sampled data streams. This stage includes the application of IRD module-specific passband calibration curves to ensure 30dB suppression of the image band.

The third step is bandwidth selection and the generation of sub-bands. This step includes the removal of an antenna specific frequency offset, requantization, and resampling to a common time standard to remove digitizer clock offsets. Finally, the data must be formatted for transmission to the correlator/beam-former, possibly over a commercial network link. A functional block diagram of the DBE is shown in Figure 23.

In the selected system architecture, the full bandwidth of each receiver band is digitized, with up to 46 GHz of bandwidth processed by the DBE in Band 6. Bandwidth selection in the DBE permits the selection of 218.75 MHz subbands across the full bandwidth of the receiver, up to the total transmitted bandwidth of 20 GHz per polarization.

The data transmissions system interface relies on commercial 400 GbE interfaces, providing 800 Gbps per antenna to the correlator over multiple data streams. The data transmission system is further described in Section 7.7. The CSP system is further described in Section 7.6.

Title: System Conceptual Design Description	Owner: Selina	Date: 2022-06-06
NRAO Doc. #: 020.10.20.00.00-0005-REP		Version: A

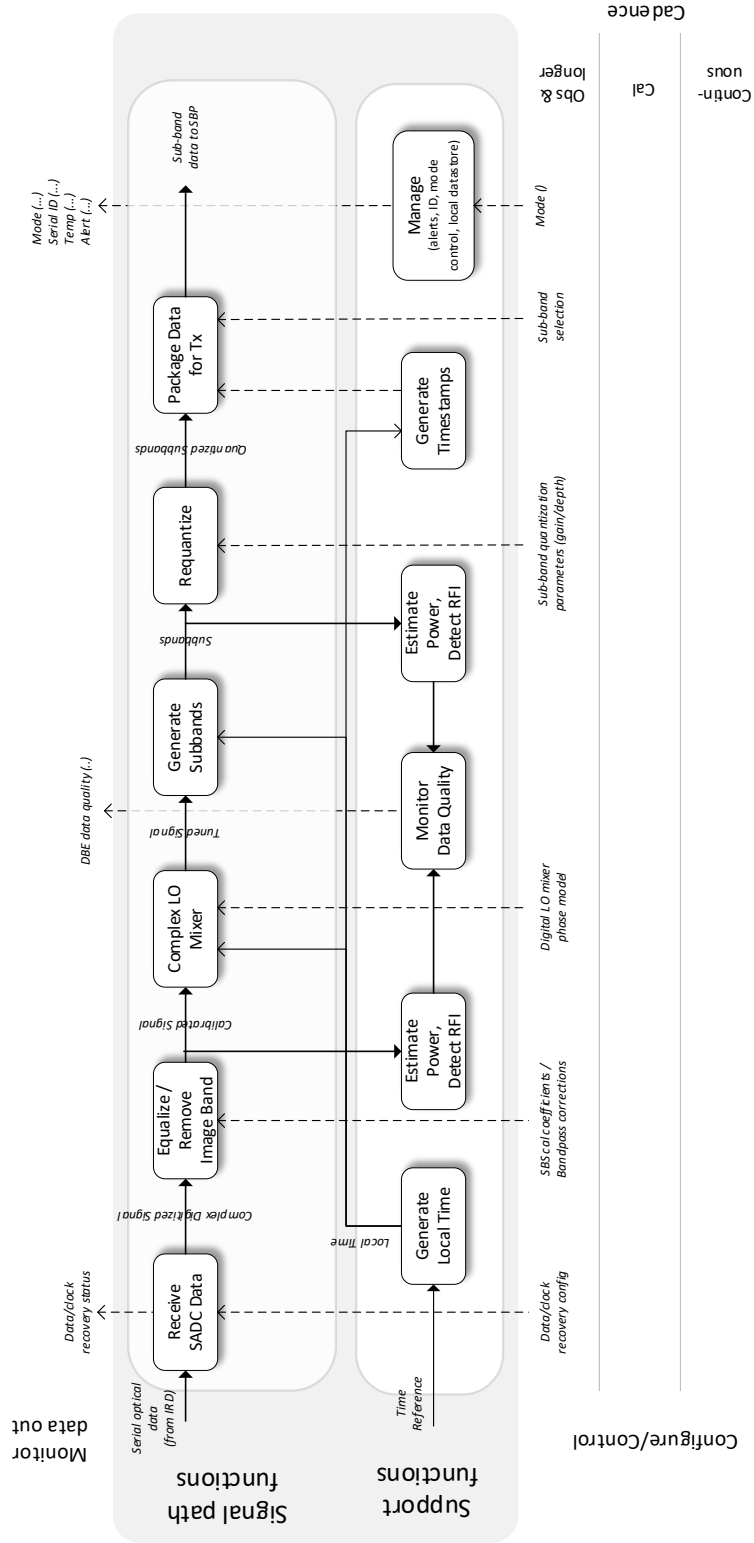

Figure 23 - Functional overview of the digital back end system. Both signal path and support functions are shown. All configuration parameters are set for the duration of an observation at a minimum, with no external feedback loops.



Title: System Conceptual Design Description	Owner: Selina	Date: 2022-06-06
NRAO Doc. #: 020.10.20.00.00-0005-REP		Version: A

7.4.5 Water Vapor Radiometer System

The requirements and supporting conceptual design of the water vapor radiometer system are described in the following documents [AD40–41]:

- Water Vapor Radiometer System: Preliminary Technical Specifications, 020.45.00.00.00-0001-REQ
- Water Vapor Radiometer System: Design Description, 020.45.00.00.00-0002-DSN

Supporting analysis leading up to this design can be found in the following documents [RD13, 14, 23–25]:

- Fast Switching Calibration at the ngVLA Site, ngVLA Memo No. 1
- Calibration Strategies for the ngVLA, ngVLA Memo No. 2
- The Concept of A Reference Array for the ngVLA, ngVLA Memo No. 4
- Considerations for a Water Vapor Radiometer System, ngVLA Memo No. 10

Early studies on the phase calibration required to correct for atmospheric disturbances [RD13] suggested relatively fast phase correction would be required, with correction cycle times of order 30 seconds. Correcting for the atmospheric phase with astronomical observations of gain calibrators (high SNR sources) would require a fast slewing antenna, and a significant portion of observing time would be spent observing the calibrator or slewing between the calibrator and science target.

To improve observational efficiency (time on science target) and possibly reduce the total tropospheric residual delay errors in an astronomical calibration cycle, the system architecture includes an independent tropospheric delay calibration system using water vapor radiometry (WVR). The WVR system constantly observes an atmospheric water vapor emission line centered at 22 GHz to calculate the column density of water vapor in the WVR beam (the primary contributor to atmospheric delay perturbations). Before the observation, a calibrator is observed (as in switching) to establish an absolute delay offset between antennas while the estimated WVR column density is noted. Monitoring changes in the water vapor column density throughout an observation permits applying phase change estimates to the science data. Periodically—but with a longer interval than that of fast switching—the calibrator can be re-observed to reestablish the atmospheric and electronic delay offset.

The WVR (shown as a block diagram in Figure 24) consists of a 1.45 meter antenna mounted to the main reflector backup structure. The fixed WVR beam is aligned parallel to the main antenna beam. The WVR antenna architecture is offset prime focus. The feed, receivers, digitizers, and support electronics are located in a receiver module mounted to the main feed arm at the offset focal point. A mounting plate connected to the antenna’s liquid cooling system provides a heat reservoir to maintain noise temperature and gain stability.

The receiver and digitizer electronics are thermally stabilized using Peltier heat pumps. A band from 19.7–31 GHz is digitized in the receiver module and digital data is streamed via fiber to the WVR back end module in the pedestal room. Digital spectra are emitted into the MCL data stream and appended to the science data so corrections can be determined and applied in post-processing. The online system may also process these spectra in real-time to aid in beamforming for phased array modes.

Title: System Conceptual Design Description	Owner: Selina	Date: 2022-06-06
NRAO Doc. #: 020.10.20.00.00-0005-REP		Version: A

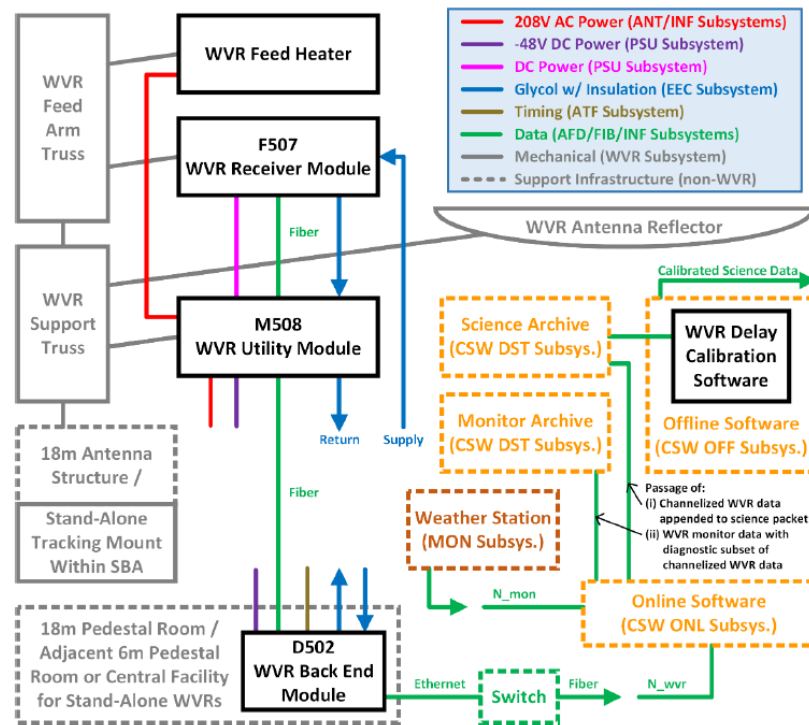

Figure 24 - WVR system block diagram and interfaces.

7.4.6 DC Power Supply System

The requirements and supporting conceptual design of the DC power supply system are described in the following documents [AD30–31]:

- DC Power Supply System: Preliminary Technical Specifications, 020.30.50.00.00-0001-REQ
- DC Power Supply System: Design Description, 020.30.50.00.00-0002-DSN

The DC power supply system provides central conversion from AC to DC, with battery backup, and common service voltages for local regulation at each module. This architecture enables centralized control and monitoring of the power supply system for sequential turn on/off and other management features that support the operations and maintenance concept.

The overall concept for the DC power supply system is based on the DC supply system of the EVLA telescope, with a central -48V supply (a common telecommunications standard) servicing DC-DC switching regulators in shielded and filtered enclosures closer to the point of service.

The DC Power Supply System receives 208V three-phase AC and converts it to -48V DC. Lithium batteries will be used as a backup source for the -48V in the event the AC supply is lost, and an integrated battery charger will charge the batteries when AC is available. The batteries and battery charger will be located in the pedestal area of each antenna. The -48V supply also directly powers the fire alarm, Ethernet switch, Digital Back End (DBE), and Data Transmission System (DTS).

The -48V is distributed to five power supply modules that convert the -48V to +32.5V, ±17.5V, ±7.5V, and +5V depending on the module and required voltages for connected equipment. Each power supply module has internal monitor and control (MCL) and temperature sensors so they can be shut down for over-current or over-temperature conditions. A block diagram of these connections is shown in Figure 25.

Title: System Conceptual Design Description	Owner: Selina	Date: 2022-06-06
NRAO Doc. #: 020.10.20.00.00-0005-REP		Version: A

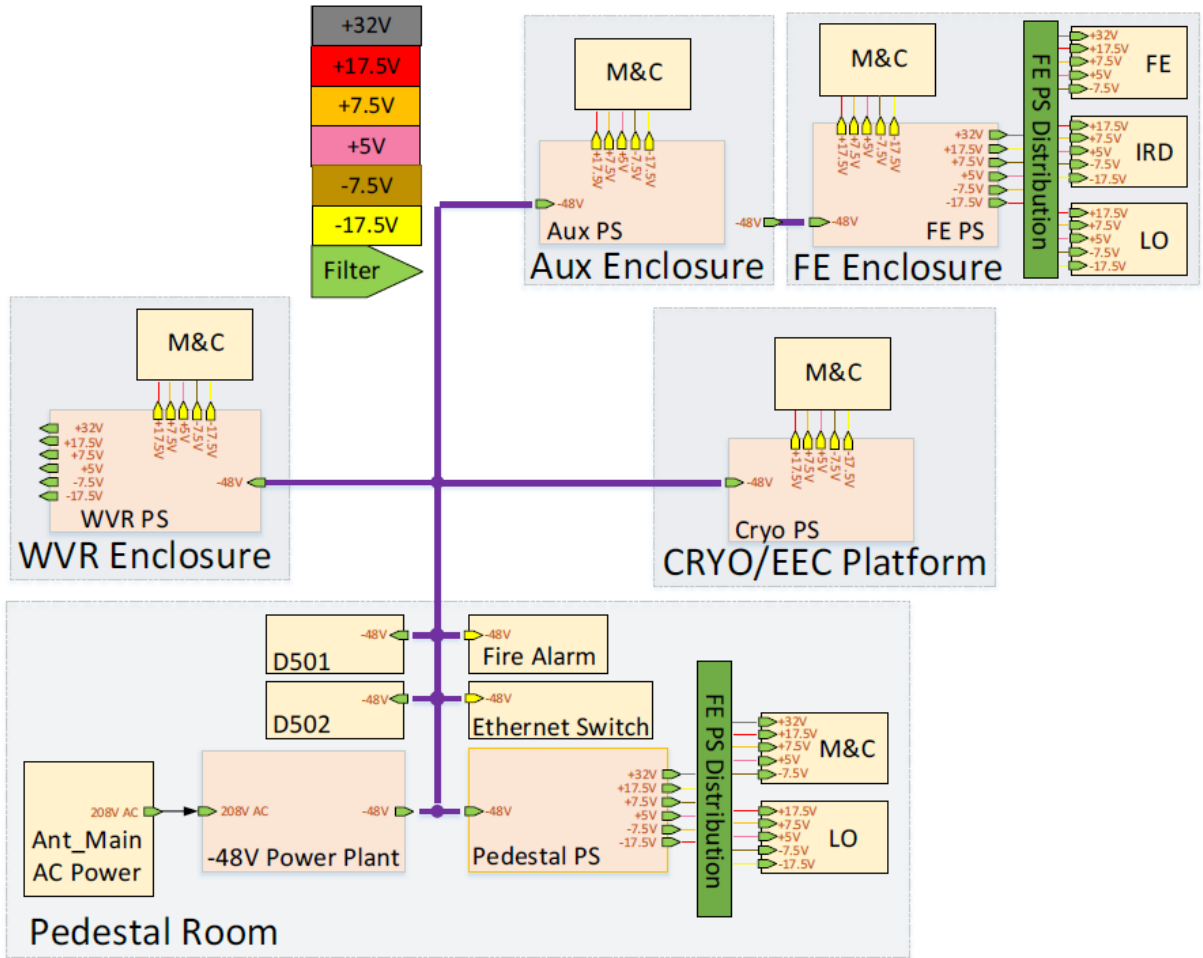

Figure 25 - Block diagram of the DC power supply system.

7.4.7 Bins, Modules and Racks

The key requirements and supporting conceptual design for the antenna electronics packaging (Bins, Modules & Racks) are described in [AD33]:

- Bins, Modules, and Racks: Design Description, 020.30.55.00.00-0002-DSN

The Bins, Modules, and Racks (BMR) subsystem includes all mechanical packaging for the antenna electronics, inclusive of environmental protection enclosures, RFI enclosures, racks, bins and standard module housings.

BMR deliverables are located at six key areas throughout the antenna (Figure 26): the Receiver Enclosure, the Auxiliary Enclosure, the FE Cable Carrier, the Electronics Rack, the Cryogenics RF Enclosure, and the Water Vapor Radiometer enclosures.

Electronics within each enclosure and the antenna pedestal are packaged into individual modules (LRUs), and the LRUs may be housed in bins. Standardized housings are used to make assembly and maintenance of the antenna electronics as simple as possible while providing adequate RFI shielding.

Title: System Conceptual Design Description	Owner: Selina	Date: 2022-06-06
NRAO Doc. #: 020.10.20.00.00-0005-REP		Version: A

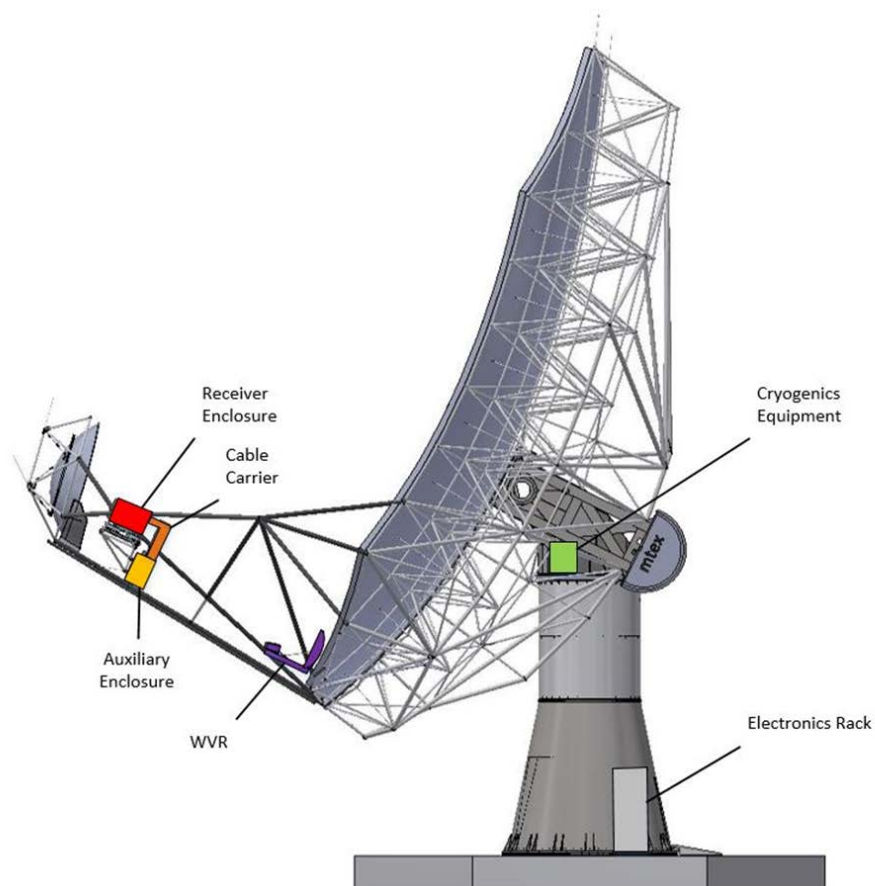

Figure 26 - Antenna electronics locations for mechanical packaging and environmental control.

The proposed modules for this subsystem are the Advanced RFI Containment System (ARCS) modules recently developed by NRAO, either the 500 or 700 series designs. The 500 series modules consist of two high-tolerance machined pieces of ATP-5 aluminum tool plate, a housing and a cover, that fit together like a clamshell leaving a cavity in the middle for mounting electronics (Figure 27). The 700 series modules are three-piece modules, made from the same ATP-5 aluminum with a central housing and individually removable side covers that allow access to the internal electronics from either side of the module, as well as allowing for dual internal cavities that may be independently RFI shielded.

Both the housing and cover module pieces can vary in width by 12.7mm (1/2") increments, so a large variety of sizes and styles can be produced. Both the housing and cover may be produced with heatsink fins for dissipating internal heat in air-cooled spaces, and the interiors can be customized with pockets or ridges to better accommodate the mounting of electrical components.

All module pieces will be chromated per MIL-C-5541-CL.III after machining in order to maintain a conductive surface. RFI shielding is achieved with double-gasket seams around the edge, utilizing low closure force fabric over foam RFI gaskets and electrically conductive pressure sensitive adhesive. A shielding level of approximately 80dB from 1GHz – 10GHz has been attained in prototypes.

Title: System Conceptual Design Description	Owner: Selina	Date: 2022-06-06
NRAO Doc. #: 020.10.20.00.00-0005-REP		Version: A

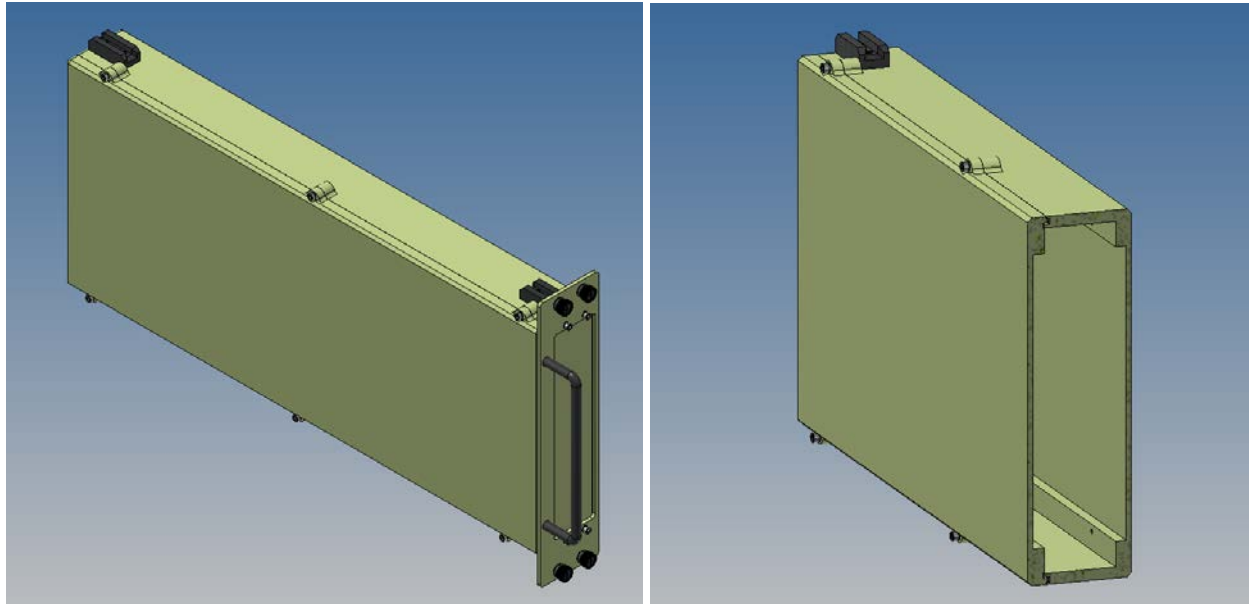

Figure 27 - 500 Series ARCS Module, closed and cross section views

Modules are typically secured in bins, with multiple modules per bin (Figure 28). Modules have guide blocks that guide the module into the bin, as well as a front panel that is used to secure the module into the bin via four captive fasteners.

Bins provide a convenient and reliable method of organizing groups of modules near one another. The standard ARCS bin is six rack units (6 RU) tall by 508mm (20”) deep, and is designed to fit into a standard EIA-310 (19”, 482.6mm) wide rack. However, bins can be adapted to reside in places other than a standard EIA rack, like in the Front End and Auxiliary Enclosures (Figure 28).

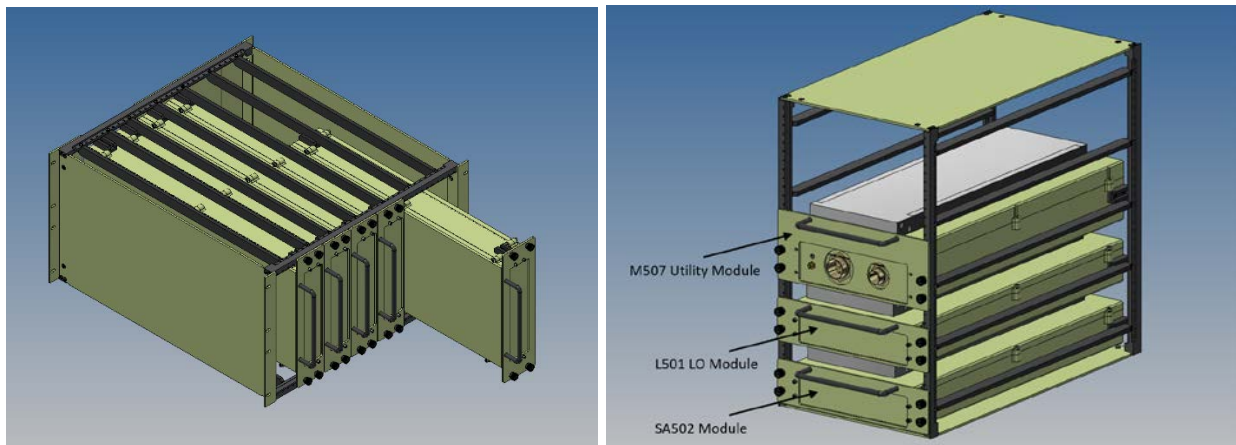

Figure 28 – Left: Multiple ARCS Modules in a standard ARCS Bin. Right: FE ARCS Bin and SA502, L501, and M507 Modules.



Title: System Conceptual Design Description	Owner: Selina	Date: 2022-06-06
NRAO Doc. #: 020.10.20.00.00-0005-REP		Version: A

7.4.8 Environmental Control

The requirements and supporting conceptual design for the environmental control system are described in the following documents [AD34–35]:

- Environmental Control: Technical Requirements, 020.30.60.00.00-0001-REQ
- Environmental Control: Design Description, 020.30.60.00.00-0002-DSN

The antenna electronics are located in various places around the antenna, as shown in Figure 26. Primary locations include but are not limited to the electronics rack in the pedestal room, the Front End and Auxiliary enclosures on the feed arm, the WVR enclosures near the base of the feed arm, and the turnhead assembly above the azimuth bearing.

The primary temperature control system consists of a cold liquid loop, a mix of water and propylene glycol, which runs from an outdoor chiller at ground level to the various service points within the pedestal, turnhead and feedarm (Figure 29). Temperature regulation at the point of service consists of either blown air over a heat exchanger or direct liquid cooling depending upon the nature of the equipment and its packaging. This central cold liquid loop also regulates the temperature of the antenna motors and drives with a single integrated system.

For the Front End, WVR and cryogenics electronics, components will be directly mounted to a liquid-cooled aluminum cold plate. The pedestal room electronics rack will be forced air cooled with a blower and heat exchanger directing cold air through the rack from bottom to top. A redundant liquid cooling loop will also be provided to permit both packaging concepts. Each LRU will include low-leakage quick-connect couplers to facilitate service.

The glycol flow control concept utilizes both manual valves and electronic proportional flow control valves. Each major enclosure or rack will include an electronic proportional flow control valve that adjusts the total flow of glycol to that location. Each consumer of glycol (e.g. cold plate, heat exchanger, etc.) will have a manual flow control valve that will be set for the required relative flow within the circuit. Once all manual valves are set, the proportional flow control valves can regulate the circuit flow, and the temperature of the equipment should largely track together. The proportional flow control valves can be used in a feedback loop to adjust the flow based on device temperature, environmental conditions, or antenna Elevation.

Title: System Conceptual Design Description	Owner: Selina	Date: 2022-06-06
NRAO Doc. #: 020.10.20.00.00-0005-REP		Version: A

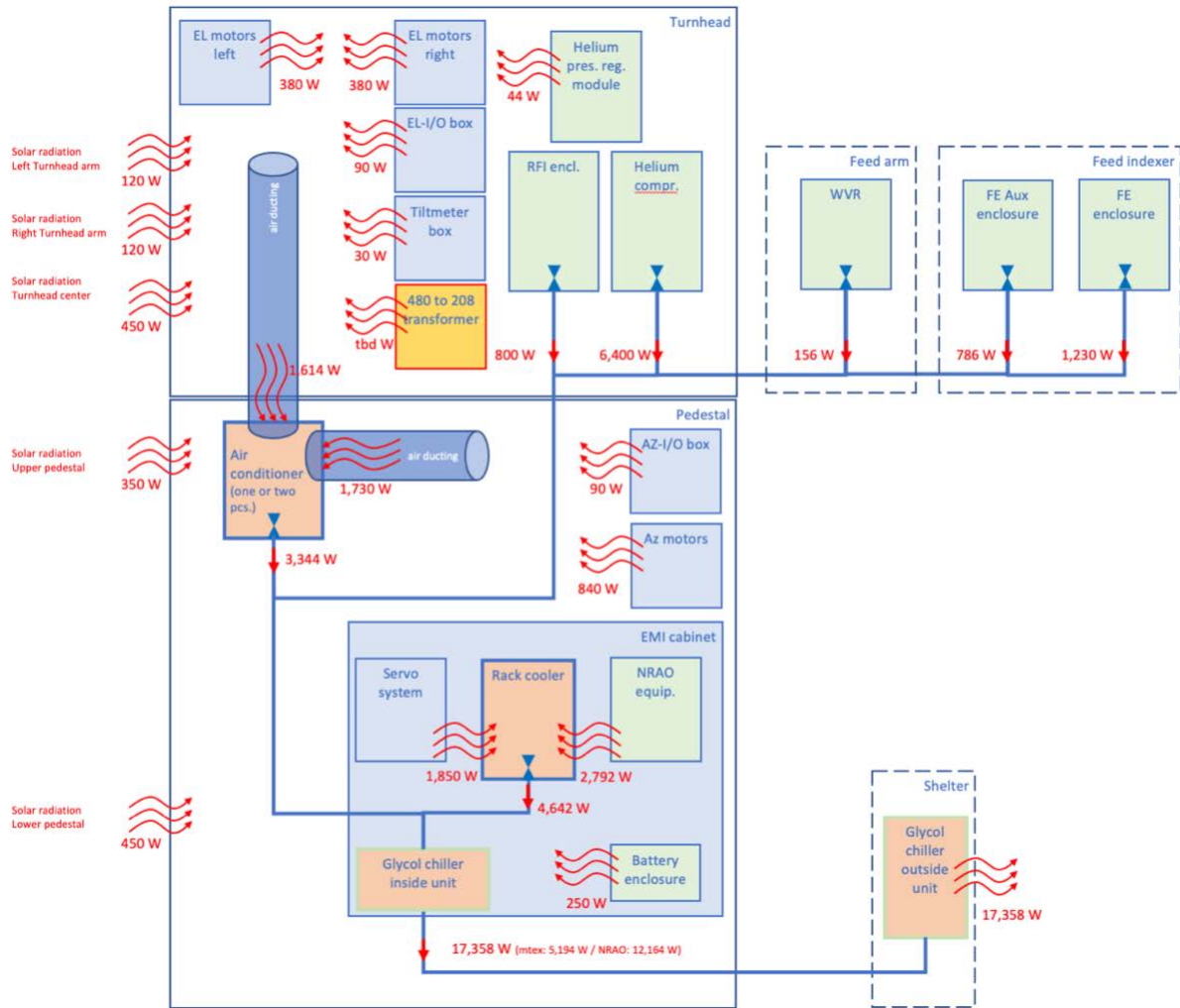

Figure 29 - Overview of the antenna environmental control system and associated heat loads.

7.5 Local Oscillator Reference and Timing

The requirements and supporting conceptual design for the time and frequency reference generation and distribution system are described in the following documents:

- LO Reference and Timing: Technical Requirements, 020.35.00.00.00-0003-REQ
- LO Reference and Timing: Design Description, 020.35.00.00.00-0002-DSN
- Antenna Time & Frequency Requirements, 020.30.35.00.00-0004-REQ

Supporting analysis leading up to this design can be found in:

- Antenna LO Trade Study, 020.30.35.00.00-0003-REP

The LO Reference and Timing (LRT) work element is responsible for supplying accurate and reliable local oscillator, sampler clock, and timing references to the relevant subsystems located at the antennas, and timing for the central signal processor (CSP) and the computing and software (CSW) subsystem.

The LO Reference and Timing system is split into three work packages: the Reference and Timing Generation (RTG) system, the Reference and Timing Distribution System (RTD), and the Antenna Time and Frequency (ATF) system.

Title: System Conceptual Design Description	Owner: Selina	Date: 2022-06-06
NRAO Doc. #: 020.10.20.00.00-0005-REP		Version: A

7.5.1 LO Reference & Timing Generation (RTG)

The LO Reference & Timing Generation system provides the primary time and frequency references for the array. A block diagram of the system concept is shown in Figure 30, with three subassemblies shown: Maser and GNSS sources, Time transfer sources, and Frequency transfer fixed sources.

The hydrogen maser is a highly accurate frequency source over short and medium timescales that function as the central frequency reference. Its output will lock the primary frequency transfer reference (in the frequency transfer fixed sources block) which will also be used to modulate a laser in a two-way round-trip phase transfer.

A timing pulse referenced to the maser will be compared to a GNSS pulse, and any timing pulse delay difference will be tracked and stored in the monitor and control database. On command, the timing pulse can be reset to the closest maser zero crossing to the GNSS timing pulse. This re-sync is only needed infrequently to stay within timing margins needed for real-time timing operations. This timing pulse is assumed to be 1 PPS, and is sent as a reference to the CSP subsystem, and input to the time transfer block where it becomes the modulation source for the timing links.

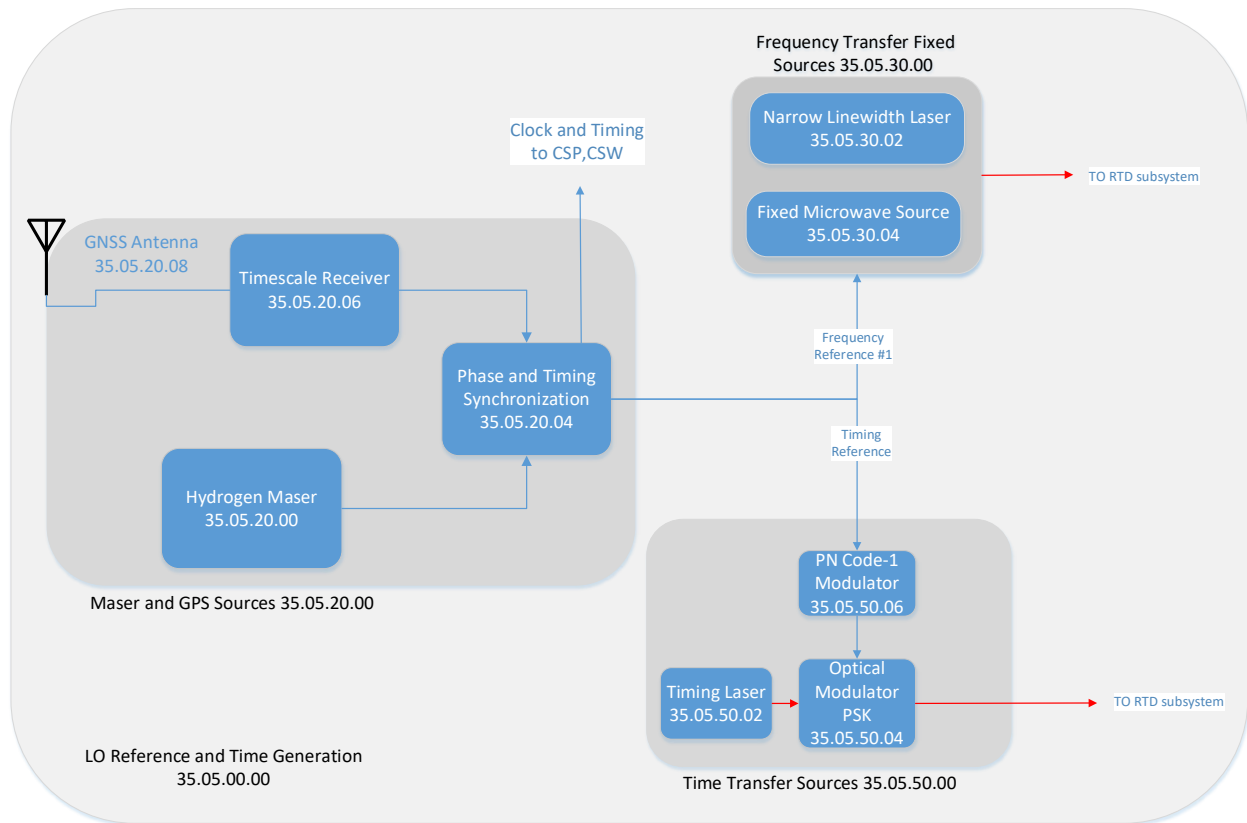

Figure 30 - LO Reference & Timing Generation (RTG) subsystem block diagram. Note that the Frequency Transfer Offset Sources are a placeholder for possible centrally generated antenna offsets.

7.5.2 LO Reference & Timing Distribution (RTD)

The LO Reference and Timing Distribution system is responsible for the distribution of coherent frequency references, inclusive of round-trip phase correction, and timing references to the antennas in the array.

Title: System Conceptual Design Description	Owner: Selina	Date: 2022-06-06
NRAO Doc. #: 020.10.20.00.00-0005-REP		Version: A

The central portion of the RTD subsystem is shown in Figure 31. Three signals are passed (on the left) from the RTG subsystem: a 1 PPS optical signal for the timing, an RF signal, and a reference laser input for the frequency transfer. The latter two are split 256 ways (allowing some spare capacity), and combined to form a frequency transfer transmitter, one per antenna station.

The 1 PPS, meanwhile is split to support N outputs, where N is the maximum number of supported high-accuracy timing links. The current design target is to deliver this reference to all directly fibered antennas, out to a distance of roughly 300km from the main array. Note that there will be LBA and distant MID stations beyond the reach of direct connection to the central building by fiber. These remote stations will require duplicates of the central RTG system and local distribution of these references within the LBA or MID station.

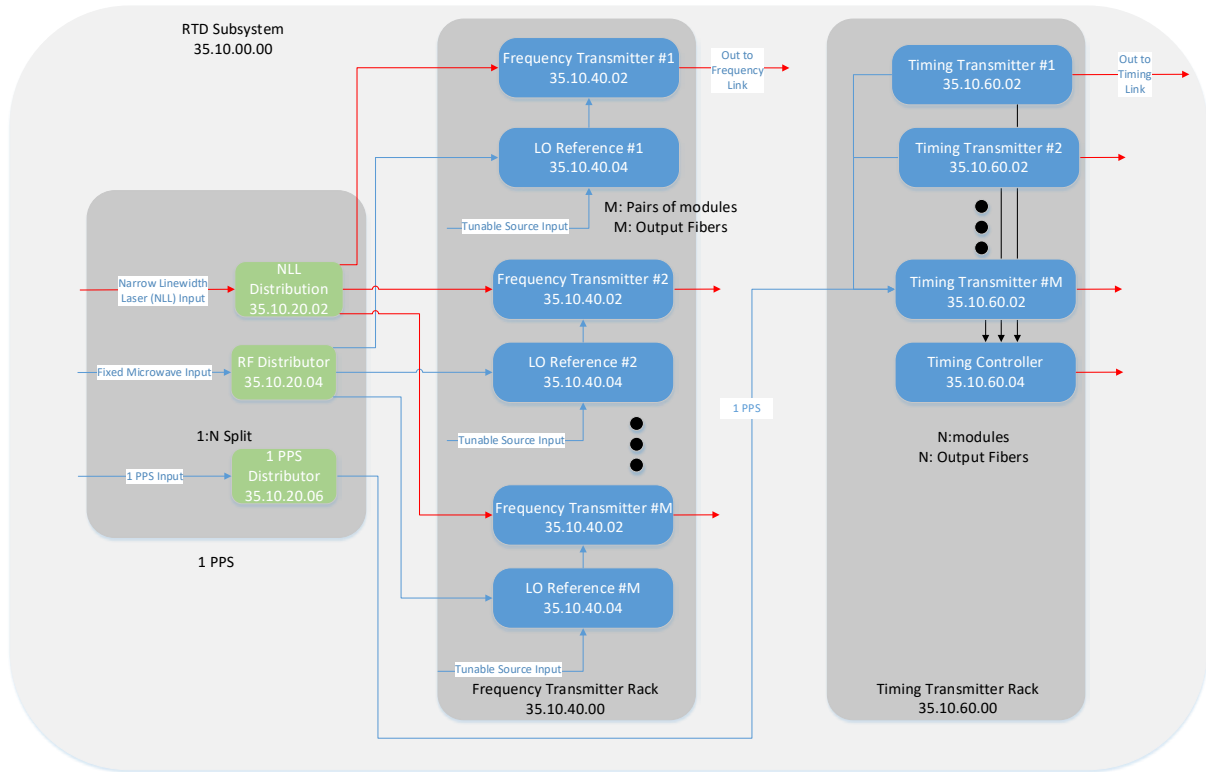

Figure 31 - LO Reference and Timing: Central Distribution (RTD) Transmitters only.

The far end of the frequency transfer link is shown in Figure 32, located at the secondary focus so that the fiber run up the antenna pedestal and feed arm can be fully compensated. The transmitted frequency is frequency shifted and reflected to support the two-way phase measurement in the central building. In addition, it may be necessary to synchronize lower frequency references in the antenna station pedestal to the main LO reference. Thus, there will be an additional tap on the LO reference located in the pedestal.

The timing transfer between central building and antenna stations will take place by means of a timing transmitter and receiver pair. The timing receiver will be located in the pedestal within the L503 LRU. As with the RTG system, the antenna time reference would be generated locally and locked to the main LO reference. The clock edge can be synchronized to the distributed timing signal on command.

Title: System Conceptual Design Description	Owner: Selina	Date: 2022-06-06
NRAO Doc. #: 020.10.20.00.00-0005-REP		Version: A

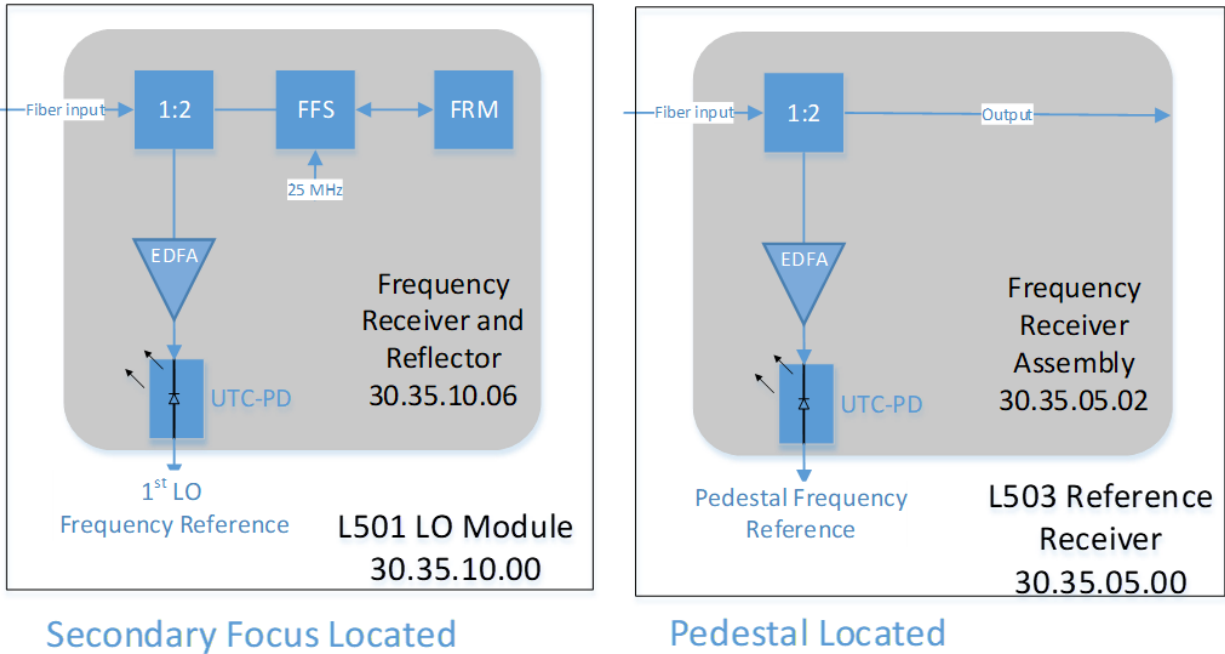

Figure 32 – Left: Frequency Transfer Link LO Reference Receiver and Reflector. Right: LO reference for pedestal-based electronics. FFS = fiber frequency shifter, FRM = Faraday rotator mirror, EDFA = erbium-doped fiber amplifier, UTC-PD = uni-traveling carrier photodiode.

7.5.3 Antenna Time and Frequency (ATF)

The selected antenna LO concept employs a simple architecture with one oscillator per downconverter, each synchronized with the antenna station frequency reference (Figure 33). The reference will be distributed optically by the RTD and received at the front end enclosure in the L501. It will then be split, amplified and buffered, and distributed to each LO module by approximately equal length, low-temperature coefficient coaxial cable. Six of the required LOs can be implemented as a simple fixed frequency phase-locked dielectric resonant oscillators (PLDRO). For IRD modules in which the LO frequency is too high to be conveniently sourced by a COTS phase locked oscillator (PLO) assembly, another block will follow the PLO containing the required frequency multiplication, filtering, and RF amplification as needed. The resultant LO frequencies are given in Table 9.

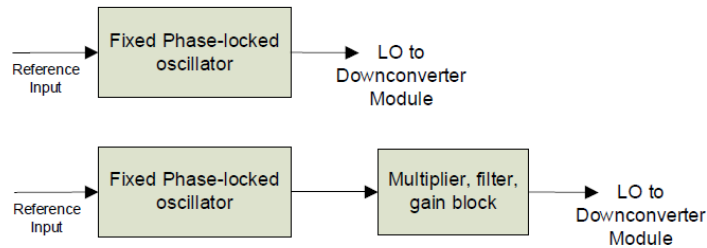

Figure 33 - Antenna LO architecture of independent frequency oscillators for each IRD downconverter module. A total of 19 LO modules are included in the design.

The packaging of the ATF LO modules and associated LRUs from the RTD system are shown in Figure 34. All ATF LO modules reside in the hatched SA501 and SA502 modules located at the secondary focus. The frequency reference from RTD is received at the L501.

Title: System Conceptual Design Description	Owner: Selina	Date: 2022-06-06
NRAO Doc. #: 020.10.20.00.00-0005-REP		Version: A

Antenna Station LRT – Block Diagram

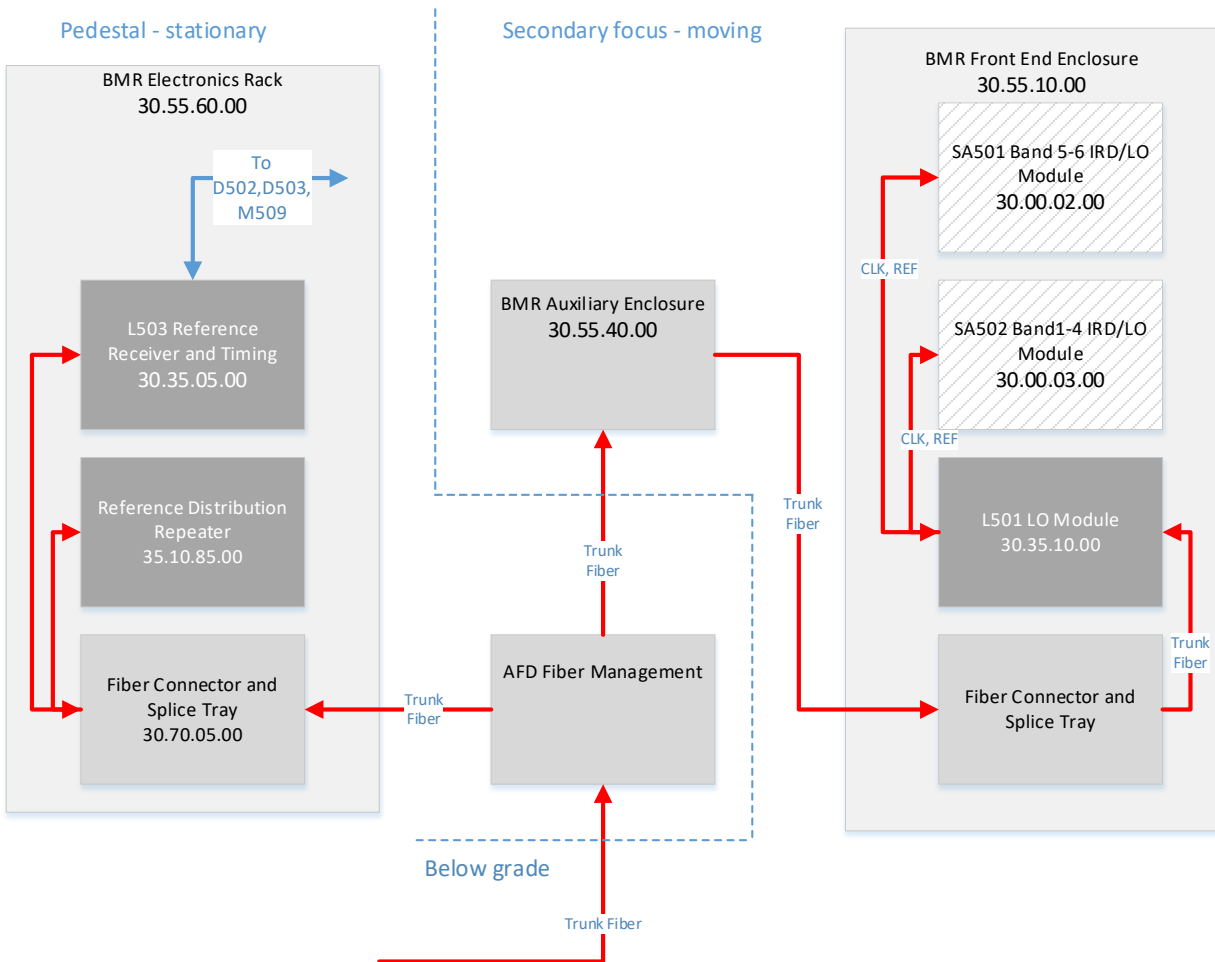

Figure 34 - LRT subsystem components at the Antenna Station. Dark shaded blocks are ATF or RTD line replaceable units, hatched blocks are Antenna Electronics modules with ATF subsystem shop replaceable units (LO modules) within. Light gray shaded blocks are Antenna Electronics elements with fiber optic pass-through. (Red=fiber optic connection)

7.6 Central Signal Processor

The requirements and supporting conceptual design of the central signal processor are described in the following documents:

- Central Signal Processor: Requirements Specification, 020.40.00.00.00-0001-REQ
- Central Signal Processor: Design Description, 020.40.00.00.00-0005-DSN

The Central Signal Processor (CSP) ingests the voltage streams recorded and packetized by the antennas and transmitted via the data transmission system, and produces a number of low-level data products to be ingested by the archive. Among its many functionalities, the CSP is responsible for

- compensating the large transmission delays from the remote stations,
- tracking the delay and phase differences between antennas,
- flagging the spectral channels corrupted with RFI at a pre-correlation stage,

Title: System Conceptual Design Description	Owner: Selina	Date: 2022-06-06
NRAO Doc. #: 020.10.20.00.00-0005-REP		Version: A

- selecting the spectral window of interest within the digitized and transmitted bandwidth,
- offsetting the different frequency standards used by the remote stations, and
- achieving the desired spectral resolution.

In addition to synthesis imaging, the CSP will support other capabilities required of modern telescopes to enable VLBI and time-domain science. The functional capabilities of the CSP include full-polarization auto- and cross-correlation computation, and beamforming capabilities for pulsar timing, pulsar/transient search, and VLBI recording.

The CSP data products will vary by operation mode. The most common will be raw/uncalibrated visibilities, recorded in a common data model. The CSP will include all necessary back end infrastructure to average visibilities and package them for the archive, where they will be recorded to disk in a standard format. Calibration of these data products will be carried out through asynchronous data post-processing pipelines in interferometric modes. Some real-time calibrations are applied in the generation of beamformed products, as described in AD09.

The CSP will support multiple sub-arrays operating simultaneously and fully independent from each other. Two key system requirements are the degree of commensality supported within a sub-array and the desired capabilities for sub-arrays operating simultaneously. At a minimum, the CSP will be able to compute auto- and cross-correlation products within a sub-array, as well as simultaneous cross-correlation and either pulsar timing, pulsar search, or VLBI capabilities for a different sub-array.

Enabling correlation and beamforming products simultaneously within a sub-array is necessary to correct in near-real time for atmospheric effects in the beamformer weights. Depending on the degree of concurrent capabilities, such a mode may also provide for localization/imaging concurrent with time-domain observations. The degree of commensality is expected to be a cost/complexity driver in the system and will be optimized on a best-value basis.

The CSP is composed of three sub-elements performing DSP tasks: the Digital Back End (DBE) at the antenna, the Sub-Band Processor (SBP), and the Pulsar Engine (PSE). Along with them, the CSP Switched Fabric (CSF) routes the data outputs from each sub-element to the next sub-element in the processing chain (Figure 35).

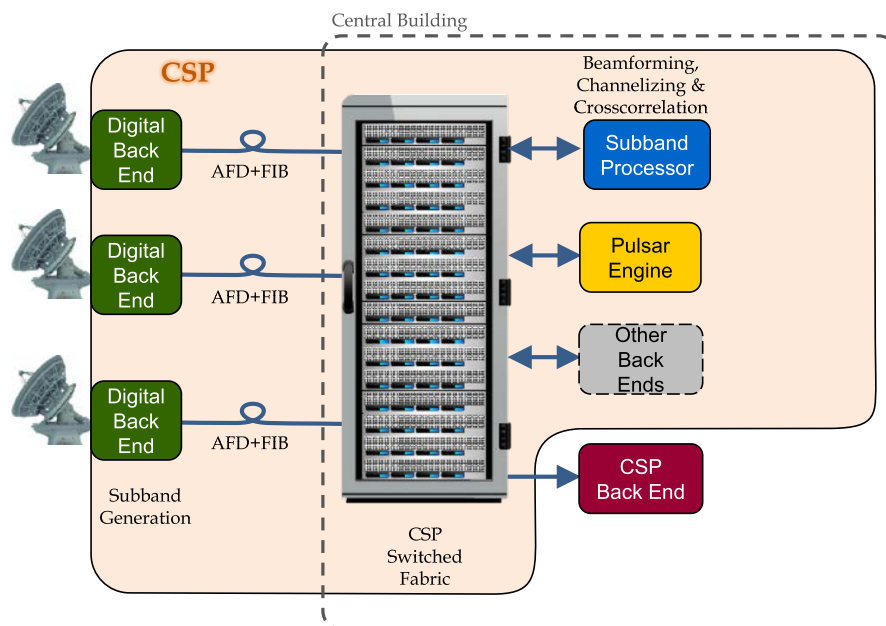

Figure 35 - CSP High-level block diagram.



Title: System Conceptual Design Description	Owner: Selina	Date: 2022-06-06
NRAO Doc. #: 020.10.20.00.00-0005-REP		Version: A

The CSP follows an F-F-X architecture when operating in interferometric mode, and an F-B-F or F-F-B (where B stands for Beamforming) architecture when operating in beamforming modes, depending on whether true time delay or phase-shift beamforming is used, respectively. Regardless of the operation mode, the first F-Engine that splits the digitized voltage into frequency sub-bands is implemented by the DBE. In the baseline design the DBE is located at the antenna sites, with the option of moving some of the units into the same building as the rest of the CSP for the sites closest to the array core. This option is only available to antennas whose distance to the CSP building is shorter than the Integrated Receiver and Digitizer (IRD) maximum transmission range. Each DBE unit processes all the digitized bandwidth for one antenna, although one DBE unit may comprise a multiplicity of identical DBE modules (2 modules in the current design concept), each module processing the signal from different receivers. Therefore, the number of units scales with the number of antennas, but the size of each individual unit depends on the processed bandwidth.

After the DBE, the remaining DSP tasks depend on the observing mode and are carried out by the SBP. As with the DBE, the SBP consists of a set of independent units, but in this case each unit processes a pair of sub-bands (or a single sub-band in high-res mode) for the whole array. Thus, the number of SBP units depends on the total instantaneous bandwidth the CSP must process, while the size of each individual unit depends on the number of antennas. In addition to the SBP, the ngVLA design of the CSP includes a custom back end, the Pulsar Engine (PSE), to perform DSP tasks specifically related to transient analysis, such as dedispersion and folding. The PSE receives beamformed data from the SBP and generates data products other than visibilities. The CSP output generated by either the SBP or the PSE is sent to the Computing and Software (CSW) Subsystem for further processing and archiving.

Except for the DBE, the other CSP sub-elements are housed in the central electronics building. The data from the various antennas' DBE are routed to the proper SBP unit by the CSF. As required by the observing mode, the data from the SBP can be sent to the PSE via the CSF for additional processing. Ideally, the CSW subsystem will connect to both sub-elements through the CSF as well. The alternative is to provide a separate network through which the SBP and the PSE can transmit their data products to the CSW. A separate communications network (different from the CSF) will carry the monitor and control data between the CSP and the CSW. The monitor and control data network is not designed with the capability necessary to sustain the CSP data output.

In addition to the DBE, the SBP, the PSE, and potentially the CSW, the CSF would also provide enough spigots to allow other custom back ends (e.g. SETI) to subscribe to sub-band data from the DBE, finely channelized⁴ or beamformed data from the SBP, correlated data from the SBP (a.k.a. visibilities), or dedispersed and/or time folded data from the PSE. If the CSW is finally connected to the CSF, the output of those custom back ends could be sent to the CSW using the CSF, e.g., for archiving purposes. This assumes that the CSW is provided with the required resources.

Key performance requirements for the correlator are summarized in Table 10.

Requirement Description	Specification
Number of Connected Antennas	263 total (minimum)
Maximum Baseline Length	8,800 km
Maximum Instantaneous Bandwidth	20 GHz per polarization in interferometric mode concurrent with 8 GHz in beamformed mode.
Maximum Number of Channels	≥240,000 channels minimum (2M channel goal)

⁴ The data flow from the second F-Engine to the X-Engine, that is, phase-delay-corrected finely frequency channelized data from each antenna, is only available for SCREAM-based SBP units.



Title: System Conceptual Design Description	Owner: Selina	Date: 2022-06-06
NRAO Doc. #: 020.10.20.00.00-0005-REP		Version: A

Requirement Description	Specification
Highest Frequency Resolution	1kHz, goal of 400 Hz, corresponding to 0.1 km/s resolution at 1.2 GHz. (15.625 kHz default resolution at full processed bandwidth)
Pulsar Search Beamforming	≥10 beams ≤700 km diameter sub-array
Pulsar Timing Beamforming	≥5 beams ≤700 km diameter sub-array

Table 10 - Correlator-beamformer key specifications.

7.7 Data Transmission System

The overall concept for the data transmission system is captured in the following documents:

- System Architecture Report, 020.10.20.00.00-0002-REP
- Central Signal Processor: Design Description, 020.40.00.00.000-0005-DSN
- Civil & Infrastructure Subsystems: Design Description, 020.60.00.00.00-0004-DSN

Additional information informing the data transmission system design can be found in:

- Long Haul Fiber Workgroup Preliminary Report, 020.60.00.00.00-0002-REP
- Trident 2.1 Concept: Updates to the CSP Reference Design, ngVLA Electronics Memo No. 5

The architecture for the data transmission system is closely integrated with the architecture of the central signal processor. As described in Section 7.6, the central signal processor architecture is an F-F-X correlator and F-B-F or F-F-B (where B stands for Beamforming) architecture when operating in beamforming modes. The first F of this architecture, always implemented as an oversampling poly-phase filter bank (PFB), resides in the Digital Back End system located in the Antenna Pedestal.

The antenna electronics architecture digitizes the full bandwidth of each receiver, up to 46 GHz of bandwidth in the case of the 70-116 GHz band. This is only feasible with a parallelized architecture that allows omitting frequency tunability. Coarse bandwidth selection would be feasible by selecting fixed digitizer subbands (5.8 GHz wide with a fixed center frequency) for transmission, but a greater degree of flexibility can be achieved by locating the PFB at the antenna, permitting bandwidth selection at approximately 218 MHz resolution across the full band, which offers a significant improvement in capabilities for spectral line modes.

This same functionality is necessary to scale transmitted bandwidth at the most remote sites. While the ngVLA project will aim to permit the transmission of 40 GHz of processed bandwidth (20 GHz per polarization) for each antenna in the array, the corresponding data rates may be cost prohibitive for the most remote long baseline sites, even in the mid-2030s when the array transitions to full operations. Incorporating the PFB at the antenna permits much finer bandwidth selection for processing (roughly by a factor of 29). Requantization can also be employed to reduce total data rates. The combination retains flexibility in performance if there is limited bandwidth at the longest baseline stations.

Accounting for the inclusion of the digital back end at the antenna, the data transmission system on the plains of San Agustin (187 antennas) can be implemented with off-the-shelf components using point-to-point links in a star network topology. Each antenna will have two (three permitted in the present design) 400 gbps links from the DBE to the CSF. 100 gbps links with a span of 40 km can be implemented today with small form factor pluggable transceivers (e.g, QSFP28s), and 400 gbps 40 km links in a pluggable form factor are anticipated well before the start of construction.

Title: System Conceptual Design Description	Owner: Selina	Date: 2022-06-06
NRAO Doc. #: 020.10.20.00.00-0005-REP		Version: A

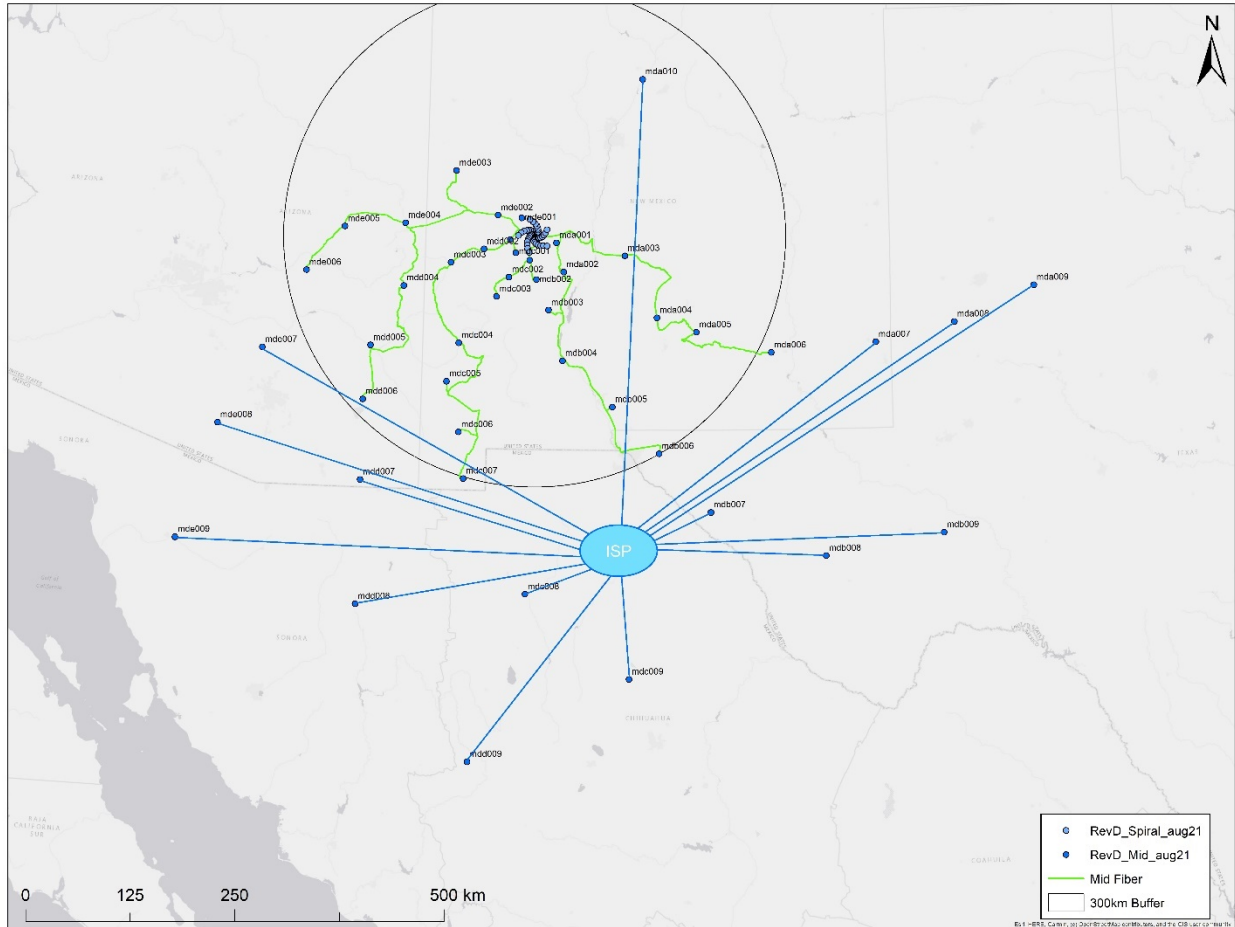

Figure 36 - Preliminary fiberoptic system layout for mid-baseline stations of the Main Array. Antennas within the core and spiral arms are direct point-to-point connections over ngVLA operated fiber. Mid-baseline stations within ~300km are connected over dedicated fiber links with repeater infrastructure housed at each antenna station. Mid-baseline stations outside the ~300 km radius, and all long-baseline stations, rely on leased bandwidth provided by network operators.

Moving off the plains of San Agustin, there are 30 mid-baseline stations in the main array that are within a 300km radius of the array core. We propose a matching architecture on these distances, with the project installing or procuring/leasing dark fiber to enable point-to-point links with repeaters and erbium-doped fiber amplifiers (EDFAs). In addition to the data transmission system, this mid-baseline fiber network will support the distribution of coherent frequency and time references from the central electronics building out to each antenna (See Section 7.5.2). Fiber counts for the Plains of San Agustin and the inner mid-baseline sites are described as part of the array infrastructure in [AD48].

Beyond the 300km radius from the ngVLA core, we propose to switch to a packet-switched network implementation where the Observatory would rely on leased bandwidth over commercial networks. This would be relevant to the remaining 16 mid-baseline stations (shown in Figure 36) and the thirty antennas located at the ten long baseline array sites.

The breakpoint between leased fiber and leased bandwidth at 300km is arbitrary, and represents a scale of construction that the project believes is feasible. Detailed discussions with network operators will be necessary to establish the availability and cost of right-of-way easements or existing dark fiber. The final



Title: System Conceptual Design Description	Owner: Selina	Date: 2022-06-06
NRAO Doc. #: 020.10.20.00.00-0005-REP		Version: A

implementation may be asymmetric and dependent on these practicalities, with some sites within the 300km radius connected through a leased bandwidth arrangement and perhaps some mid-baseline arms connected beyond this distance with dark fiber.

The extent of the array and the use of commercial packet switched networks will introduce a significant variation in latency between antennas (approximately 250 ms). The correlator includes the requisite functionality to buffer the incoming data streams from each antenna and correctly sequence the packetized and formatted data for all three topologies. The required network infrastructure at the central site is comparable to what ISPs provide to small metropolitan areas and can be procured off-the-shelf today (at significant cost). Technology cycles over the project design phase are expected to make the selected DTS concept affordable for both construction and operation. Should this assumption not be realized, the bandwidth at the 46 remote antennas could be throttled at the DBE to fit within cost constraints.

7.8 Computing and Software System

The requirements and supporting design architecture of the online and offline computing and software systems are described in the following documents:

- Computing & Software Systems: Preliminary Technical Requirements, 020.50.00.00.01-0001-REQ
- ngVLA System-Level Architecture, 020.10.20.00.00-0002-REP

Supporting analysis leading up to this design architecture can be found in the following memos:

- Software Requirements for RFI Management, ngVLA Computing Memo #3
- Size-of-Computing Estimates for ngVLA Synthesis Imaging, ngVLA Computing Memo #4
- High Performance Gridding, ngVLA Computing Memo #5
- Baseline HPG Runtime Performance for Imaging, ngVLA Computing Memo #7
- Designing an ngVLA Dynamic Scheduler, ngVLA Computing Memo #6
- RFI Mitigation for the ngVLA: A Cost-Benefit Analysis, ngVLA Memo #70
- RFI Mitigation in the ngVLA System Architecture, ngVLA Memo #71

NRAO has been migrating towards the delivery of higher-level, quality-assured data products (e.g., calibrated image cubes) as part of a broader Observatory initiative to deliver Science Ready Data Products [RD05]. This initiative has led to the recent update of the telescope time allocation and proposal submission tools, and a new data archive. Algorithmic and pipeline development has also focused on the practicalities of reducing VLA and ALMA data and parallelizing the CASA software infrastructure in anticipation of ngVLA-scale data sets. ngVLA, as a new facility within the NRAO, will leverage and interface with this Observatory-level software infrastructure and extend it to meet project requirements.

The development of the Science Ready Data Products infrastructure for the VLA and ALMA, especially the updates to the pipelines and data reduction algorithms, act as an ngVLA pathfinder. The development and commissioning of standard observing modes and the identification of common high-level data products to be delivered to the Principal Investigator and the data archive to facilitate data reuse can inform the ngVLA observing modes, data product definition, and pipeline design. Adopting this framework and operations model will enable the facility to support a broader user base, possibly catering to astronomers who are not intimately aware of the nuances of radio interferometry and thereby facilitating multi-wavelength science.

The array will have a progressive series of data products suitable to different user groups. The data products will also change based on how well supported a mode is: common standard modes should have higher-level data products that add value to the user, while clearly not all permutations can benefit from such a degree of automation.



Title: System Conceptual Design Description	Owner: Selina	Date: 2022-06-06
NRAO Doc. #: 020.10.20.00.00-0005-REP		Version: A

As with the VLA and ALMA, the fundamental data product that will be archived are uncalibrated visibilities. The online software system will also produce flags to be applied to the visibilities that would identify known system problems such as antennas being late on source, or the presence of RFI.

Automated post-processing pipelines will calibrate the raw data and create higher-level data products (typically image cubes) that will be delivered to users via the central archive. Calibration tables that compensate for large-scale instrumental and atmospheric effects in phase, gain, and bandpass shapes will be provided. Data analysis tools will allow users to analyze the data directly from the archive, reducing the need for data transmission and reprocessing at the user's institution.

The computing and software systems will be distributed across several of ngVLA sites: control systems will be deployed in the Central Electronics Building, while the Science Archive and post-processing systems will be deployed in the Science Operations and Data Center.

7.8.1 Software System Structure

The software system is composed of five main elements:

- (a) **Proposal Management System (PMN):** This subsystem supports the ngVLA telescope time allocation processes, including the solicitation of proposals for each observing cycle, the proposal submissions from PIs, the review process and time allocation, approval and closeout processes. It supports these processes through the Telescope Time Allocation (TTA) System, a common NRAO system for all its supported telescopes. The ngVLA Proposal Management System extends the TTA system to comply with its specific requirements. The PMN system supports the transformation of the proposals that have been awarded observation time each observing cycle into scheduling blocks as well.
- (b) **Online SW Subelement (ONL):** The online subsystem selects scheduling blocks and executes them in a subarray. It coordinates all operations necessary to perform observations, resulting in archived low-level data products. The system reads configurations and calibrations from the telescope configuration database and applies them in the corresponding telescope subsystems. It continuously monitors the state of the telescope, saving the monitoring data and alarms in the Engineering database. This database also includes integrated logs generated by all software components as they perform their operations.
- (c) **Offline SW Subelement (OFF):** This subsystem is responsible for all post-observation operations performed on the collected low-level data products, including the generation of derived high-level data products (such as calibrated image cubes), support for quality assurance activities, and the provision of interfaces to search for and retrieve data products.
- (d) **Data Stores (DST):** The data stores included in this package are logical and are deployed into physical storage systems and databases depending on their requirements. They may be consolidated or segregated as necessary.
- (e) **Monitor and Control System (MCL):** This system is composed by software components necessary to connect the high-level software with the telescope hardware. It provides a level of isolation between a high-level model of the array and the low-level details involved in accessing its hardware, using the OPC-UA protocol.

Figure 37 shows the main software system data flows. The PMN system handles the proposal management processes through several services. Proposals are eventually transformed into a set of scheduling blocks, which are read and executed by the ONL subsystem. The ONL subsystem commands the telescope hardware by means of the MCL subsystem. The scheduling blocks execution results in sub-band data being

Title: System Conceptual Design Description	Owner: Selina	Date: 2022-06-06
NRAO Doc. #: 020.10.20.00.00-0005-REP		Version: A

sent from the CSP to the ONL subsystem, which then processes it and sends the science data products for ingestion into the OFF subsystem archive. The MCL subsystem captures engineering data which is sent to the Engineering Database and the Maintenance Support subsystem (MSS). Once the science data is received by the OFF subsystem, it is processed to generate high-level science-ready data products.

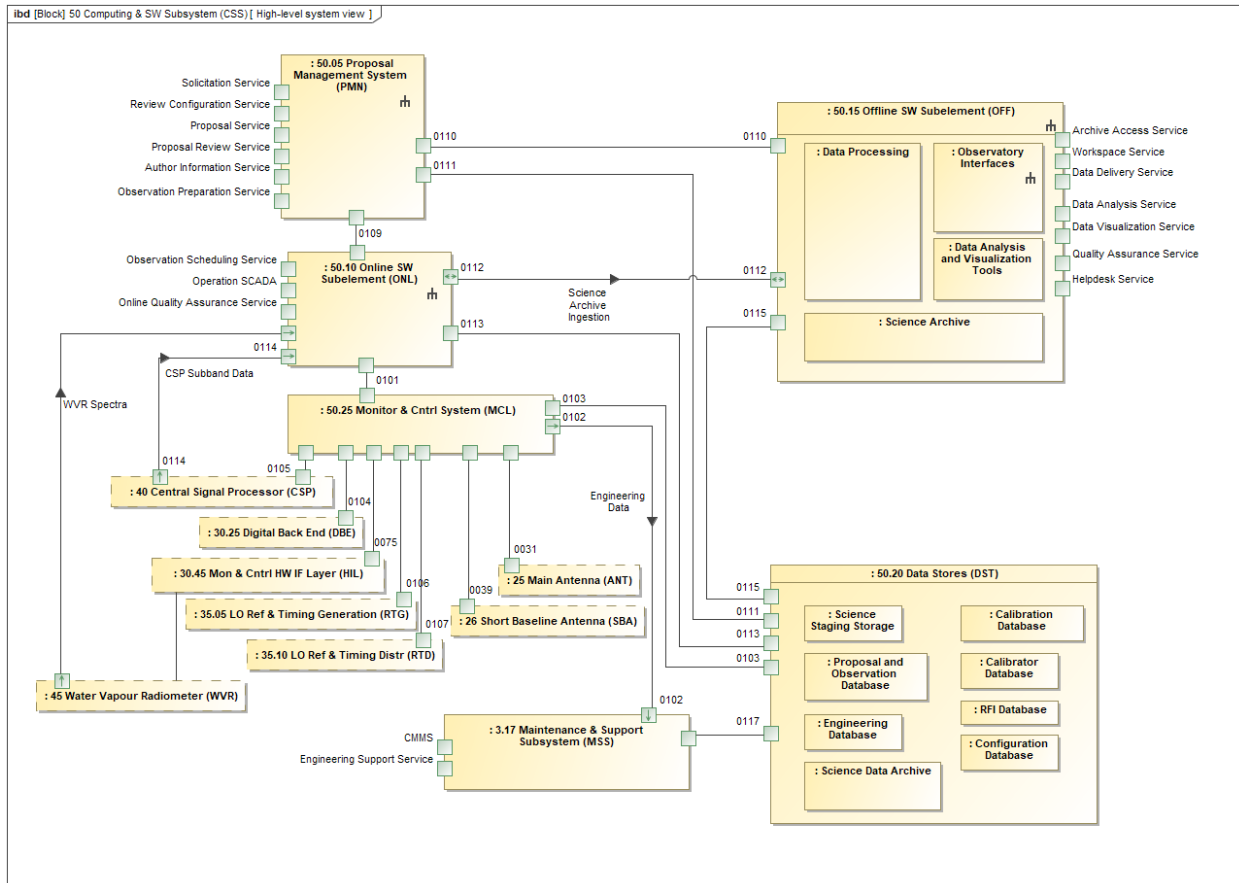

Figure 37 - Internal block diagram of the Computing & Software System.

This diagram shows a high-level view of the entire system. External user interfaces are shown as unconnected ports (e.g. Solicitation Service, Review Configuration Service, etc.), and connected ports represent the internal interfaces. The diagram also shows the main data streams (CSP Subband Data from the CSP, Science Data for archival ingestion, and Engineering Data). This diagram also shows the primary hardware components that the system interacts with, through the Monitor and Control System.

Figure 37 also shows the main user interfaces to the system. These are:

- (a) **Solicitation Service:** The Solicitation Service supports configuring and opening a solicitation, modifying capabilities, and testing proposal validation.
- (b) **Review Configuration Service:** The Review Configuration Service supports managing review groups, assigning reviewers to groups, and assigning proposals to reviewers.
- (c) **Proposal Service:** The Proposal Service supports creating and vetting proposals.



Title: System Conceptual Design Description	Owner: Selina	Date: 2022-06-06
NRAO Doc. #: 020.10.20.00.00-0005-REP		Version: A

- (d) **Proposal Review Service:** The Proposal Review Service supports Panel Proposal and Observatory Site review processes.
- (e) **Author Information Service:** The Author Information Service supports accessing author information via the NRAO Account System or configuration files.
- (f) **Observation Preparation Service:** Interface that allows the user to generate scheduling blocks from proposal data or from scratch, and to edit and validate the scheduling blocks afterwards.
- (g) **Observation Scheduling Service:** This interface allows an Operator to create, destroy and query sub-arrays and interact with the scheduling algorithms. This interface aggregates information about the status of the antennas, allowing the Operator to visualize the sets of antennas that can be used in specific sub-arrays. It allows the starting and stopping of Scheduling Block (SB) execution, and queries of the state of executing SBs.
- (h) **Operation SCADA:** The Supervisory Control and Data Acquisition system used by Operators to control the array and monitor the array system health.
- (i) **Online Quality Assurance Service:** A Graphical User Interface (GUI) to present online QA data.
- (j) **CMMS:** This interface allows Operations staff to access the Computerized Maintenance Management System. This system provides several functions aimed to effectively organize maintenance operations.
- (k) **Engineering Support Service:** This interface allows Engineering support staff to access data from the Engineering Database and provides integrated services to support maintenance operations.
- (l) **Archive Access Service:** This Web application allows users to browse and search the Archive contents and retrieve data. It will be based on the present Archive Access Tool, adapted for ngVLA.
- (m) **Workspace Service:** This Web application lets users access their workspace, where they save references to data products and queries, submit post-processing requests, and manage their execution.
- (n) **Data Delivery Service:** Interface to allow users to download datasets from NRAO Science Archive.
- (o) **Data Analysis Service:** Interfaces to perform local and remote data analysis operations. These can be browser-based (e.g., Jupyter notebook) and/or based on ngCASA tools.
- (p) **Data Visualization Service:** Interface to visualize large images (e.g. CARTA).
- (q) **Quality Assurance Service:** This Web application allows QA personnel to access job execution information, Weblogs, etc. The application permits introducing comments and performing actions to follow up QA decisions (accept data products, reject data products, submit for re-processing, submit Helpdesk issues, etc.).
- (r) **Helpdesk Service:** This interface provides access to NRAO Helpdesk, which allows users to submit and follow up problems related with observations and post-processing jobs.

Additional information on each subelement of the computing and software system is available in AD09.

Title: System Conceptual Design Description	Owner: Selina	Date: 2022-06-06
NRAO Doc. #: 020.10.20.00.00-0005-REP		Version: A

7.8.2 Monitor and Control System

The Monitor and Control (MCL) system is a sub-component of the Online System, but given its importance in baselining the hardware system design it is summarized here. The overall concept for the MCL system and supporting requirements for the hardware interface layer are described in the following documents:

- Monitor & Control System: Design Concept, 020.50.25.00.00-0002-DSN
- Monitor & Control System Hardware Interface Layer: Preliminary Requirements, 020.50.25.00.00-0001-REQ

The MCL system leverages NRAO experience with both the VLA and ALMA MCL systems. It is designed for high reliability, maintainability, and usability to decrease operational and maintenance costs. In general, the ngVLA MCL concept is guided by two complementary principles:

- The system should be based on autonomous and decoupled components controlling smart devices.
- The system should be organized and managed as a hierarchically connected system.

Following these considerations, the ngVLA MCL system will be structured in layers, each responsible for converting a higher-level parameter into a lower-level one. The software hierarchy also follows the logical breakdown of the underlying hardware. At a high level, an array or sub-array is treated as a singular entity, while lower layers in the hierarchy deal with managing correlator resources, individual antennas, or specific devices within an antenna. An example of this organization is shown in Figure 38. While hardware devices represent physical LRUs and are static, the other levels (Subarray, Antenna, etc.) are software entities instantiated dynamically when a sub-array is created.

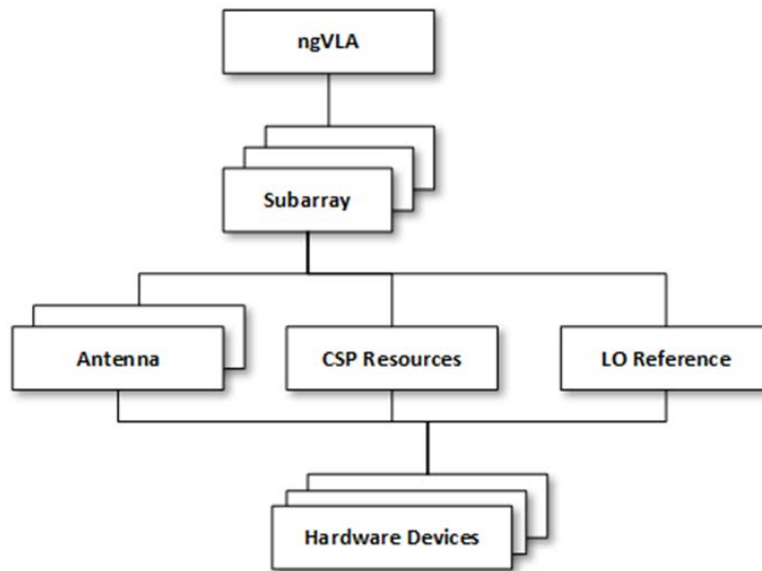

Figure 38 – Logical view of the ngVLA control system. [AD44]

The software architecture is derived from ANSI/ISA-95, an international standard for developing interfaces between “enterprise” software (in our case “observatory” software) and industrial control systems. For the purposes of the ngVLA MCL system, the ISA-95 layers have been re-defined as:

- **Level 0 - Hardware Device Layer:** The hardware elements that are directly involved in the physical processes of an astronomical observation.



Title: System Conceptual Design Description	Owner: Selina	Date: 2022-06-06
NRAO Doc. #: 020.10.20.00.00-0005-REP		Version: A

- **Level 1 – Intelligent Device Layer:** Intelligent devices for sensing and manipulating. Involves the hardware elements that sense and manipulate the devices in the signal path. These are hardware interface (HIL) boards, the CSP, and other LRUs. The processes involved in these operations have typical time frames of less than a second (ms and μ s).
- **Level 2 - Supervisory Control and Monitoring:** Control systems for monitoring and supervision. The systems that supervise, monitor and control the physical processes. Includes Distributed Control Systems (DCS), Human-Machine Interfaces (HMI), Supervisory Control and Data Acquisition (SCADA) software. The relevant time frame is typically seconds to minutes.
- **Level 3 - Observation Operation Layer:** Systems involved in managing the observation workflows to produce the desired science datasets. The typical time frame is minutes to hours.
- **Level 4 - Observatory Planning and Logistics Layer:** Manages the activities of the observatory. The Proposal Management System is the primary system in this level, establishing the long-term observatory time allocation, schedules, etc. The relevant time frame is days and months.

The lowest layer consists of the hardware itself, for example the antenna drive motors, optical encoders, thermal or vacuum sensors, or frontend electronic components. Communications with hardware are typically done over fieldbus protocols, such as Ethercat, Modbus, Ethernet/IP, but in our case chip-to-chip protocols like SPI and I2C have been selected, given the proximity of the Level 1 devices (HIL boards for antenna devices) and the need to comply with strict RFI emission requirements. Chip-to-chip protocols are easier to implement and require less digital circuitry on hardware devices, limiting emissions.

Level 1 devices are typically PLCs in industrial applications, but have traditionally been custom boards within NRAO (such as the ALMA AMBSIs or EVLA MIBs) due to RFI requirements. The functions allocated to these devices are usually fairly limited (mostly protocol translation), but as the computing power of these types of devices has increased in the last years it may be advantageous for them to perform additional functionality (e.g., high frequency sampling for condition-based maintenance alerts and troubleshooting). Logically they are the last layer of translation, going from OPC UA commands (e.g. switch to a receiver band) to hardware commands (e.g. the binary SPI or I2C commands to move the feed indexer). ngVLA will leverage an open platform system-on-module or system-on-chip architecture with an in-house carrier design for most of the hardware interface boards at Level 1. The use of the OPC UA standard will also enable easy integration with commercial devices (e.g., the PLCs in the Antenna Control Unit) where these are more suitable and higher emissions can be tolerated.

Layer 2 is the Supervisory Control and Data Acquisition (SCADA) system, which includes the remote operator interfaces; and local HMI systems (local displays). Within the logical breakdown, both the antenna management and subarray management systems fall into Layer 2. These systems are responsible for collecting monitoring data, and distributing commands to execute the current observation.

Layer 3 represents processes that drive the observation operations, such as observation scheduling, maintenance management, and array performance analysis. The Proposal management system is an example of a long-term planning tool that belongs to Layer 4.

In industrial control systems, devices sometimes communicate directly with one another rather than using the hierarchical system to coordinate between related processes. This mechanism is supported by implementing both an OPC UA server and client in an HIL controller, although it is not currently anticipated that the ngVLA system will have such a requirement.

Regarding allocation of real-time requirements, it is assumed that real-time constraints are localized to individual devices and will be implemented in the Intelligent Device Layer. An example is the pointing commands to the antenna, which must be applied with high precision timing. In this case, the hard real-time deadlines are handled by the Antenna Control Unit. The Supervisory Layer is only required to send a stream of periodic time-tagged azimuth and elevation position updates with enough anticipation for them to be applied at the right time.



Title: System Conceptual Design Description	Owner: Selina	Date: 2022-06-06
NRAO Doc. #: 020.10.20.00.00-0005-REP		Version: A

Each LRU should be autonomous and come up in an operational state after power up and initialization. The HIL controllers should detect when an LRU has powered up and should execute an initialization routine if necessary. At this point, the HIL should report the existence of the device to the rest of the system through an event and the device should become accessible through the corresponding OPC UA interface. Besides its unique S/N identifier, each LRU has a defined type that identifies what kind of module it is, and a role that identifies where it is installed in the system and to which systems it is connected to. This message will be received by the Supervisor, which will configure itself accordingly. The initialization routine should also include a built-in diagnostic, which could also be invoked on demand.

Hardware and telescope-specific parameters will be stored in a database which can be accessed when initializing devices. Each antenna supervisor will cache values when possible for redundancy. These parameters will be associated with hardware devices based on the device serial number, such that even when devices are moved from one antenna to another they can be retained properly. Antenna specific parameters (e.g. pointing model, foundation locations, etc.) will be persistently associated with a given antenna and stored within the configuration database. The configuration database will also support versioning, so it will be possible to retrieve the history of how the parameters have changed over time.

Tracking this information is fundamental for the application of automated diagnostics and preventive maintenance algorithms. It will also facilitate developing tools that facilitate the task of gathering all the necessary information needed to troubleshoot problems effectively.

7.8.3 Offline Subsystem Sizing

The Offline Subsystem is responsible for all the telescope functions that occur after an observation's raw data has been stored in the Science Archive. These functions include the generation of derived data products (image cubes), support for quality assurance activities, and interfaces for searching, visualizing, and retrieving science products. Table 11 shows the telescope's expected rates for interferometric data, estimated from the science cases included in the ROP [AD56]. These figures are large enough to make it unlikely that end users will have in-house computational resources to calibrate and image the raw data locally, so providing these computational resources is central to the ngVLA facility concept. This changes the present interaction model for most users - instead of downloading the visibility data and using a full data reduction software package on local computing resources, high-level data products will be generated by the observatory for all standard observing modes. Services will also be provided for the user to perform quality assurance, submit jobs for custom pipeline re-processing, and carry out analysis and visualization over these high-level data products.

Science Case	Use Fraction	Vis Per Hour	Data Rate	Storage Rate
KSG1 Driving Cont. Band 6 e.g. Taurus disk	9%	73.19 GVis	0.081 GB/s	0.21 PB/Month
KSG1 Driving Cont. Band 4 e.g. Taurus disk	4%	216.28 GVis	0.240 GB/s	0.63 PB/Month
KSG2 Driving Line Band 5 e.g. Sgr. B2(N)	4%	97241.83 GVis	108.046 GB/s	284.14 PB/Month
KSG2 Driving Line Band 4 e.g. Sgr. B2(N)	1%	72129.85 GVis	80.144 GB/s	210.76 PB/Month
KSG2 Driving Line Band 3 e.g. Sgr. B2(N)	1%	119342.01 GVis	132.602 GB/s	348.72 PB/Month
KSG3 Driving Line Band 5 e.g. COSMOS	4%	5985.35 GVis	6.650 GB/s	17.49 PB/Month
KSG3 Driving Line Band 4 e.g. COSMOS	1%	2996.82 GVis	3.330 GB/s	8.76 PB/Month



Title: System Conceptual Design Description	Owner: Selina	Date: 2022-06-06
NRAO Doc. #: 020.10.20.00.00-0005-REP		Version: A

Science Case	Use Fraction	Vis Per Hour	Data Rate	Storage Rate
KSG3 Driving Line Band 3 e.g. COSMOS	1%	3030.45 GVis	3.367 GB/s	8.85 PB/Month
KSG3 Driving Line Band 6 e.g. Spiderweb galaxy	2%	11.16 GVis	0.012 GB/s	0.03 PB/Month
KSG3 Driving Line Band 5 e.g. Spiderweb galaxy	1%	11.16 GVis	0.012 GB/s	0.03 PB/Month
KSG3 Driving Line Band 4 e.g. Spiderweb galaxy	1%	5.58 GVis	0.006 GB/s	0.02 PB/Month
KSG3 Driving Line Band 6 e.g. Virgo Cluster	7%	3232.05 GVis	3.591 GB/s	9.44 PB/Month
KSG3 Driving Line Band 1 e.g. M81 Group	11%	149.48 GVis	0.166 GB/s	0.44 PB/Month
KSG3 Driving Line Band 1 e.g. M81 Group	13%	4.66 GVis	0.005 GB/s	0.01 PB/Month
KSG5 Driving Cont. Band 1 OTF Find LIGO event	7%	7347.53 GVis	8.164 GB/s	21.47 PB/Month
KSG5 Driving Cont. Band 4 OTF Find LISA event	7%	1090.82 GVis	1.212 GB/s	3.19 PB/Month
KSG5+4 Driving Cont. Band 2 OTF Find BHs + Possible Pulsars	4%	2034.17 GVis	2.260 GB/s	5.94 PB/Month
KSG5 Driving Cont. Band 3 Gw170817@200Mpc	24%	4.18 GVis	0.005 GB/s	0.01 PB/Month
Avg.:		6898.09 GVis	7.665 GB/s	20.16 PB/Month

Table 11 - Expected data rates, from key science use cases. It is assumed that full polarization is required, and visibilities are stored in half precision (2 bytes/number), with no baseline dependent averaging.

As described in [RD33], it is estimated that a system with a computing capacity of 60 PFLOPs/second will be necessary (inclusive of 20% reprocessing capacity) in order to calibrate and image the input visibility data rate of ~2 GVisibilities/second. This estimate assumes that the dominant contributor in the cost of computing is the process of interpolating the visibility data to/from a regular grid prior to performing the FFT (a.k.a. gridding and de-gridding) and the correction of direction-dependent effects by means of the application of convolutional operators (or Convolution Functions, CF) at the same time that the data is gridded. These direction-dependent effects include compensating for the non-coplanarity of the array, and the effect of the primary beam for different frequencies when observing wide fields of view. Other contributors, such as the execution of deconvolution algorithms to account for the imperfect sampling of the (u, v) -space, calibration, and other overheads are introduced as factors in the model. For now, these factors have been estimated conservatively, while prototype software is being developed and test platforms are procured to measure their values and scaling behavior.

To decrease the cost of the computing platform necessary to support the high-level data product delivery paradigm, the data processing architecture will incorporate Graphical Processing Units (GPUs) to perform the gridding and de-gridding operations. A basic early prototype was developed to assess the potential of the technology [RD33], and a more complete version was developed subsequently, integrating the GPU-gridder into CASA in such a way that large-scale parallelization tests are possible [RD79]. These tests subsequently show that a current state-of-the-art GPU (NVIDIA Tesla V100) can sustain a processing rate of 4 MVisibilities/second if the overheads of computing and transferring the CFs into the GPU can be made small enough. The data processing architecture will need to optimize the transfer of the CF data into the



Title: System Conceptual Design Description	Owner: Selina	Date: 2022-06-06
NRAO Doc. #: 020.10.20.00.00-0005-REP		Version: A

GPU in order to fully occupy the computational power of the GPU. Several alternatives are also being studied, including moving the computation of the CF into the GPU.

Processing ngVLA observations will require a super-computer with hundreds to thousands of computer nodes equipped with GPUs (500 nodes, if the processing rate of 4 MVis/sec can be realized). This level of parallelization will require extensive changes in the CASA code, including optimizing the use of memory, breaking down monolithic tasks into components that can be executed in multiple machines, a new data format designed to optimize I/O operations, and a pipeline system that can manage thousands of parallel jobs, with complex dependency graphs, that can withstand hardware failures in one or more nodes while processing.

Parallelizing at this scale can be challenging due to the effects of serial operations and overheads. One example of this for ngVLA is the process of deconvolution, which is executed after transforming the gridded visibilities from (u, v) -space to the sky image. Amdahl's law is often cited to illustrate the inherent difficulty of large-scale parallelization [RD82]. As the level of parallelization increases, the runtime decreases only up to the point where serial operations dominate. After this, additional parallelization has very little effect on runtime. However, in our case the level of parallelization can be adjusted to grow at the same rate as the size of the problem (the number of visibilities). For these type of problems (a.k.a. weak-scaling problems), the effect of serial operations is described by Gustafson law, which does not suffer from this saturation [RD83]. The scaling behavior of the ngVLA, described by the parallelization efficiency (the ratio of the actual speedup and the ideal speedup) is a critical parameter for the data processing system. Measuring and optimizing this parameter, considering all relevant serial operations and overheads, is an important activity during the design and development phase of the project.

Other approaches to reduce the cost of data processing are being explored. One of them is applying baseline-dependent averaging. The (u, v) -tracks for long baselines need to be sampled frequently to prevent time-smearing effects. Short baselines, on the other hand, do not need to be sampled with the same frequency. Given that the ngVLA array configuration is concentrated in the core and spans a wide range of baselines, using different integration times can substantially reduce the rate of visibilities that the system needs to process. Similar studies for the SKA suggest that a data rate reduction of ~87% may be possible [RD84]. This strategy can be applied in different places in the system: in the CSP, the CBE, before archive ingestion, or even before post-processing. The choice of implementing baseline-dependent averaging before or after the archive ingestion step dictates if the visibilities are recorded at full time resolution or post-averaging. If the reduction in the data rate is not only necessary to reduce the cost of data processing, but also of archive storage, then averaging before archive ingestion is preferred. However, such an approach does risk limiting the reuse of the short baseline data for other use cases and may limit reprocessing capabilities.

Another strategy is the application of other wide-field corrections algorithms besides w-projection. Preliminary investigations suggest that the use of w-projection in combination with facets for the main array, and the use of w-stacking for some baselines when combining the main array with the long baseline array, can decrease the number of operations with minimal effect on the quality of the final images. This study will continue in the preliminary design phase.

A final approach to constrain the cost of data processing is programmatic. As shown in Table N, the data rates vary significantly between projects. The most demanding use cases make up only 10% of projected observing time in the ROP, but constitute 88% of the estimated computing load [RD33]. The remaining 90% of use cases use cases can be performed with a 6 PFLOPs/second system. Deferring the implementation of these most demanding use cases, or implementing them to partial specification (e.g., limiting imaging dynamic range in low-frequency, full-band, full-beam imaging) may constrain the cost of the computing system within the construction project scope. In all scenarios, limiting the cost of the project will require constraints on the total computing system delivered. Observing time and data

Title: System Conceptual Design Description	Owner: Selina	Date: 2022-06-06
NRAO Doc. #: 020.10.20.00.00-0005-REP		Version: A

reprocessing of these most demanding use cases may need to be constrained in early operations to the projected levels of the ROP or less. Computing resources associated with standard observing modes will need to be treated as finite, and allocated to the highest-ranked projects. This model is analogous to the allocation of observing time, and would use a similar process.

7.9 Buildings and Array Infrastructure

The requirements and supporting conceptual design for the buildings and array infrastructure are described in:

- Civil and Infrastructure Subsystems: Requirements Specification, 020.60.00.00.00-0003-REQ
- Civil and Infrastructure Subsystems: Design Description, 020.60.00.00.00-0004-DSN

The civil and infrastructure subsystems include the array infrastructure, the ngVLA site buildings, the maintenance center, repair center, array operations center (collectively referred to as the operations buildings), data center and science operations center. A context diagram showing the facilities in the vicinity of the array core is shown in Figure 39.

The array infrastructure includes the antenna foundations (see Figure 40), service roads, electrical infrastructure, fiber infrastructure, and ancillary structures (e.g., fences) necessary to support each antenna within the array.

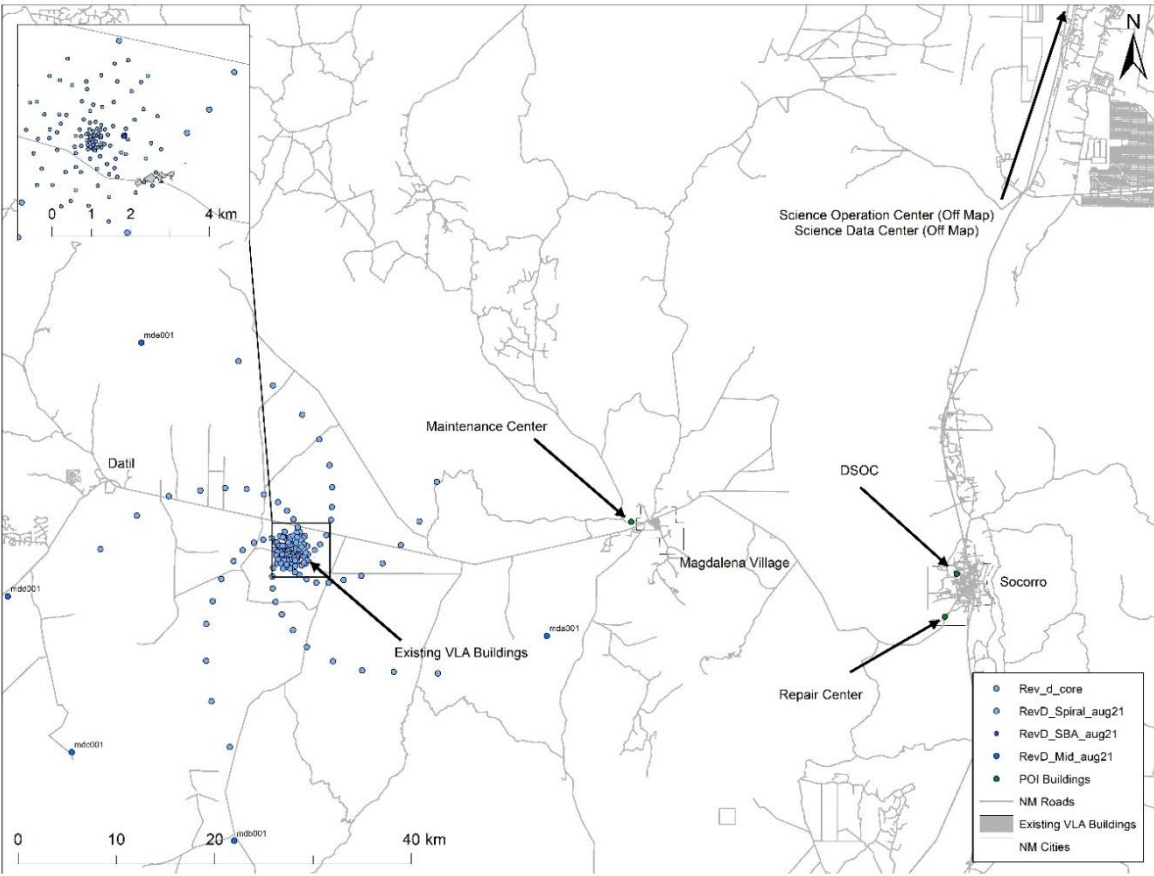

Figure 39 - A site context diagram for infrastructure and buildings. The array infrastructure sub-system must connect all antenna sites to necessary services (power, fiber, roads). The sites of various buildings are also shown for context. The Maintenance Center, Repair Center and Array Operations Center (existing DSOC) are elements of the Operations Buildings package. The Science Operations Center and Science Data Center are off map.

Title: System Conceptual Design Description	Owner: Selina	Date: 2022-06-06
NRAO Doc. #: 020.10.20.00.00-0005-REP		Version: A

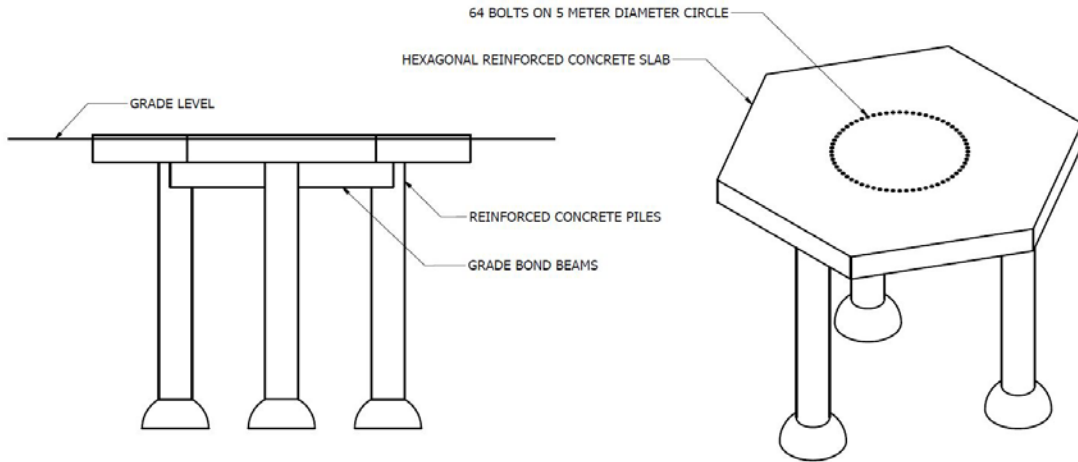

Figure 40 - Antenna foundation supports. Note that site grade is approximately level with the pad, and the piles extend below grade. The 64 1.75" diameter bolts on a 16.896' [5150mm] circle form the primary interface to the antenna pedestal.

Most ngVLA infrastructure and buildings will be located on the Plains of San Agustin. Over 70% of the antennas fit within the array's core and spiral arms. The electrical distribution system will be underground on the plains, with the service roads and utility trenches sharing a common alignment to reduce total disturbance (Figure 41). Electrical switchgears are distributed around the array center, each servicing approximately 30 antennas. Redundant electrical paths will permit preventive maintenance on most switchgears without removing power to the rest of the array. The site will also include redundant backup generators to maintain operation during power outages.

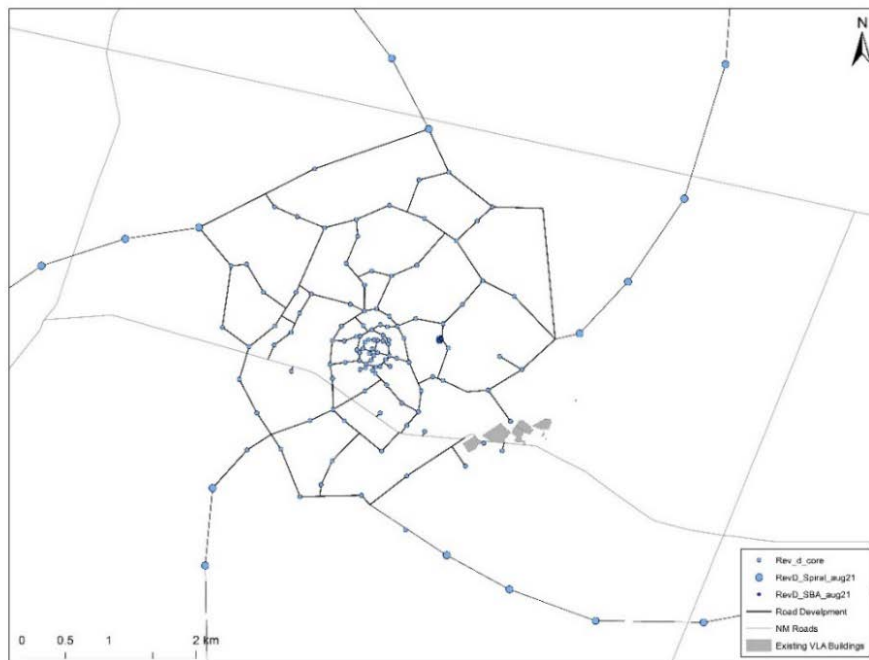

Figure 41 - Road and trench configuration for the ngVLA central core and spiral arm antennas.

Average total power load is estimated at 5.9MW for the array, central infrastructure, and off-site buildings combined. This is approximately five times the current VLA load. Estimates are based on a combination



Title: System Conceptual Design Description	Owner: Selina	Date: 2022-06-06
NRAO Doc. #: 020.10.20.00.00-0005-REP		Version: A

of parametric scaling from the VLA and bottom-up estimates for new designs, apportioned as shown in Table 12. The main power source on the plains is expected to be grid power provided by the local utility company. Green power sources (e.g., photovoltaics) have been considered and are increasingly attractive on operating price and broader impact metrics, but are presently outside the scope of construction.

Location	Subtotal
Array Antennas (SBA, MA, LBA)	3586 kW
Central Infrastructure (inc. CSP)	1066 kW
Off-Site Buildings (AOC, Data Center)	1210 kW
Grand Total (kW)	5862 kW

Table 12 - Approximate average electrical power load.

The fiber infrastructure will share the utility trench with the power distribution system. It is a star topology, with all fibers terminating at the central electronics building (housing the central signal processor). Other infrastructure systems at the site include water and waste systems, trash transfer, and fire suppression. Stations outside the plains will leverage existing infrastructure where available, with electrical infrastructure providing “last mile” connections, and fiber strung along existing pole line right-of-ways. Sites beyond ~300 km from the core will rely on commercial fiber links for data backhaul as shown in Figure 36. Diesel generator costs and impacts will be compared to full-site battery backup to maintain system availability at the mid-baseline and long-baseline antenna sites.

An assessment of the existing buildings and infrastructure has been performed by a 3rd party AEC firm, providing recommendations for reuse of VLA infrastructure and new construction where appropriate. The buildings concept leverages the existing VLA buildings where reuse is most economical over the lifetime of the facility. The primary facility construction at the site will consist of a new central electronics building to house the central signal processor and reference distribution electronics.

A new maintenance center will be constructed (likely near Magdalena) for supporting technical service crews focused on HVAC, electrical, cryogenics, servo and antenna mechanical service. A warehouse and machine shop will be included as part of this facility.

Additional operation centers are included within the building package required for facility operation. These include an Array Operations Center (the existing DSOC) and Repair Center in Socorro, as well as a Science Center and Data Center in a remote metropolitan area. This complement of facilities is in direct response to the requirements derived from the Operations Concept, which outlines the distribution of operations and maintenance activities across the array.



Title: System Conceptual Design Description	Owner: Selina	Date: 2022-06-06
NRAO Doc. #: 020.10.20.00.00-0005-REP		Version: A

8 Appendix

8.1 Acronyms and Abbreviations

Acronym	Description
2SB	Dual Sideband Separating
AC	Alternating Current
ACFH	Axially Corrugated Feed Horn
AD	Applicable Document
AEC	Architecture, Engineering and Construction
AIV	Assembly Integration and Verification
ALMA	Atacama Large Millimeter/submillimeter Array
AMBSI	ALMA Monitor and Control Bus Standard Interface
ARCS	Advanced RFI Containment System
AST	Division of Astronomical Sciences (NSF)
ATF	Antenna Time & Frequency
BMR	Bins, Modules & Racks
BW	Band Width
CARTA	Cube Analysis and Rendering Tool for Astronomy
CASA	Common Astronomy Software Applications
CBE	Correlator (or CSP) Back End
CBF	Correlator Beam-Former
CDL	Central Development Laboratory
CDR	Conceptual Design Review
CF	Convolution Function
CMMS	Computerized Maintenance Management System
COTS	Commercial Off The Shelf
CSIRO	Commonwealth Scientific and Industrial Research Organization
CSP	Central Signal Processor
CSF	CSP Switched Fabric
CSV	Commissioning and Science Validation
CSW	Computing and Software
CW	Continuous Wave (Sine wave of fixed frequency and amplitude)
DBE	Digital Back End
DC	Direct Current
DCS	Distributed Control Systems
DS	Decadal Survey / Direct Sampled
DSOC	Domenici Science Operations Center
DSP	Digital Signal Processing
DST	Data Stores
DTS	Data Transmission System
EDFA	Erbium-Doped Fiber Amplifiers
EIA	Electronics Industries Association/Electronics Industries Alliance
EIRP	Effective Isotropic Radiated Power
EMC	Electro-Magnetic Compatibility
ENOB	Effective Number of Bits
EOP	Envelope Observing Program
FDR	Final Design Review



Title: System Conceptual Design Description	Owner: Selina	Date: 2022-06-06
NRAO Doc. #: 020.10.20.00.00-0005-REP		Version: A

Acronym	Description
FE	Front End
FFT	Fast Fourier Transform
FOV	Field of View
FSA	Frequency Slice Architecture
FWHM	Full Width Half Max
GM	Gifford-McMahon
GNSS	Global Navigation Satellite System
GPIO	General Purpose Input-Output
GPU	Graphics Processing Unit
GUI	Graphical User Interface
GW	Gravitational Wave
HIL	Hardware Interface Layer (Board)
HMI	Human-Machine Interface
HPC	High Performance Computing
HVAC	Heating, Ventilation & Air Conditioning
I-Q	In-phase & Quadrature
I2C	Inter-Integrated Circuit (Interface)
ICD	Interface Control Document
IF	Intermediate Frequency
IRD	Integrated Receiver Digitizer
ISP	Internet Service Provider
KPP	Key Performance Parameters
KSG	Key Science Goals
LBA	Long Baseline Array
LNA	Low Noise Amplifier
LO	Local Oscillator
LRT	LO Reference & Timing
LRU	Line Replaceable Unit
MA	Main Array
MCL	Monitor & Control
MIB	Monitor & Control Interface Board
MJD	Modified Julian Date
MoE	Measure of Effectiveness
MoP	Measure of Performance
MREFC	Major Research Equipment and Facilities Construction (NSF)
MSS	Maintenance Support Subsystem
NASA	National Aeronautics and Space Administration
NDA	Non-Disclosure Agreement
NES	Near Earth Sensing
ngVLA	Next Generation VLA
NOAA	National Oceanic and Atmospheric Administration
NRCC	National Research Council Canada
NRAO	National Radio Astronomy Observatory
NSF	National Science Foundation
OFF	Offline Software Subelement
OIR	Optical/Infrared
ONL	Online Software Subelement



Title: System Conceptual Design Description	Owner: Selina	Date: 2022-06-06
NRAO Doc. #: 020.10.20.00.00-0005-REP		Version: A

Acronym	Description
OPC UA	Open Platform Communications Unified Architecture
PBS	Product Breakdown Structure
PDR	Preliminary Design Review
PI	Principal Investigator
PFB	Polyphase Filter Bank
PFLOPS	Peta (10 ¹⁵) Floating Point Operations Per Second
PLC	Programmable Logic Controller
PLDRO	Phase-Locked Dielectric Resonant Oscillator
PLL	Phase Locked Loop
PLO	Phase Locked Oscillator
PMN	Proposal Management System
PPS	Pulse Per Second
PSD	Power Spectral Density
PSE	Pulsar Engine
PST	Proposal Submission Tool
PWV	Precipitable Water Vapor
QA	Quality Assurance
QRFH	Quad Ridge Feed Horn
RD	Reference Document
RFI	Radio Frequency Interference
rms	Root Mean Square
ROP	Reference Observing Program
RSS	Root of Sum of Squares
RTD	Reference & Timing Distribution
RTG	Reference & Timing Generation
RTP	Round Trip Phase
RVTM	Requirements Verification Traceability Matrix
S/N	Serial Number
SAC	Science Advisory Council
SB	Scheduling Block
SBA	Short Baseline Array
SBP	Sub-Band Processor
SCADA	Supervisory Control And Data Acquisition
SEFD	System Equivalent Flux Density
SKA	Square Kilometer Array
SNR	Signal to Noise Ratio
SPI	Serial Peripheral Interface
SRDP	Science Ready Data Products
SWG	Science Working Group
SysML	Systems Modeling Language
TBC	To Be Confirmed
TBD	To Be Determined
TP	Total Power
TTA	Telescope Time Allocation
UTC	Coordinated Universal Time
VFD	Variable Frequency Drive
VLA	Jansky Very Large Array



Title: System Conceptual Design Description	Owner: Selina	Date: 2022-06-06
NRAO Doc. #: 020.10.20.00.00-0005-REP		Version: A

Acronym	Description
VLB	Very Long Baseline (>500km)
VLBI	Very Long Baseline Interferometry
WVR	Water Vapor Radiometer











020.10.20.00.00-0005-REP-SYSTEM_CONCEPTUAL_DESIGN

Final Audit Report

2022-06-06

Created:	2022-06-06
By:	Alicia Kuhn (akuhn@nrao.edu)
Status:	Signed
Transaction ID:	CBJCHBCAABAASg81UQXc27PgbgRGMen2dscJ-HBiRXv-

"020.10.20.00.00-0005-REP-SYSTEM_CONCEPTUAL_DESIGN" History

-  Document created by Alicia Kuhn (akuhn@nrao.edu)
2022-06-06 - 5:11:28 PM GMT- IP address: 107.242.117.31
-  Document emailed to Rob Selina (rselina@nrao.edu) for signature
2022-06-06 - 5:13:37 PM GMT
-  Email viewed by Rob Selina (rselina@nrao.edu)
2022-06-06 - 5:25:15 PM GMT
-  Document e-signed by Rob Selina (rselina@nrao.edu)
Signature Date: 2022-06-06 - 5:28:09 PM GMT - Time Source: server
-  Document emailed to Thomas Kusel (tkusel@nrao.edu) for signature
2022-06-06 - 5:28:14 PM GMT
-  Email viewed by Thomas Kusel (tkusel@nrao.edu)
2022-06-06 - 5:31:59 PM GMT
-  Document e-signed by Thomas Kusel (tkusel@nrao.edu)
Signature Date: 2022-06-06 - 5:32:45 PM GMT - Time Source: server
-  Document emailed to E. J. Murphy (emurphy@nrao.edu) for signature
2022-06-06 - 5:32:50 PM GMT
-  Email viewed by E. J. Murphy (emurphy@nrao.edu)
2022-06-06 - 5:33:26 PM GMT
-  Document e-signed by E. J. Murphy (emurphy@nrao.edu)
Signature Date: 2022-06-06 - 5:33:44 PM GMT - Time Source: server



 Document emailed to Willem Esterhuyse (westerhu@nrao.edu) for signature

2022-06-06 - 5:33:49 PM GMT

 Email viewed by Willem Esterhuyse (westerhu@nrao.edu)

2022-06-06 - 5:37:24 PM GMT

 Document e-signed by Willem Esterhuyse (westerhu@nrao.edu)

Signature Date: 2022-06-06 - 5:37:47 PM GMT - Time Source: server

 Agreement completed.

2022-06-06 - 5:37:47 PM GMT

